



“World’s Most Efficient”



Air To Water Heat Pumps
(a/k/a Reverse Cycle Chillers a/k/a
Hydronic Heat Pumps)



ENERGY STAR 2019
Emerging Technology Award



Welcome to Chiltrix!

The Ultra-Efficiency Solution to “All Electric Home” HVAC systems and Net Zero energy.

Why all-electric? Because there are no panels you can install on the roof that make gas or oil.

In this presentation we will focus on the Chiltrix features & technology. The “World’s Most Efficient Air To Water Heat Pump”

ENERGY STAR 2019
Emerging Technology Award

The Chiltrix ultra-high efficiency air-to-water heat pump CX34 has been awarded the EPA **ENERGY STAR 2019/2020 Emerging Technology Award**



Chiltrix Air-To-Water Heat Pumps



Basic System Overview – High Level

- Chiltrix air to water heat pumps use the proven “monoblock” design, meaning that all refrigerant and associated components such as compressor, evaporator, condenser etc. are all self-contained and sealed in the outdoor unit.
- The outdoor unit connects to indoor equipment via insulated water lines (water or water/glycol).
- No refrigerant is ever inside the building envelope.

Simplified typical example

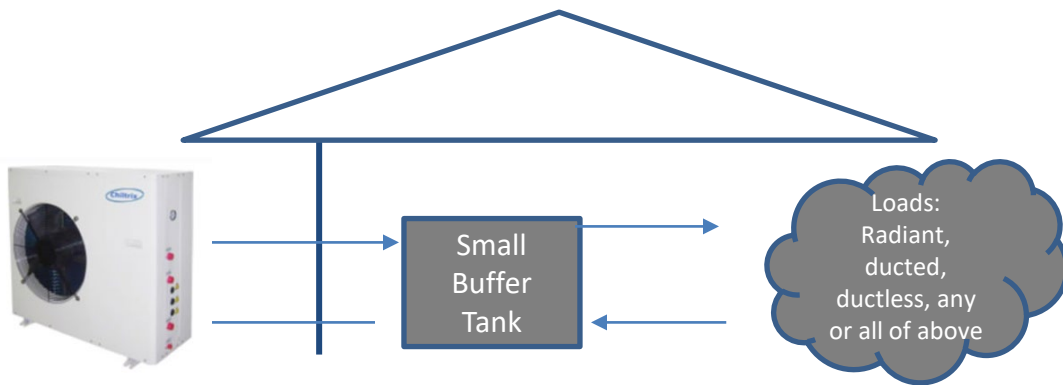

Can be used for radiant heating or cooling, ductless fan coil units, ducted air handler, or a combination using any or all of these can be used in a single installation.





Chiltrix Air-To-Water Heat Pumps

Basic System Overview - Features



Suitable For Any Combination of:

- Cooling
- Heating
- Domestic Hot Water (DHW)

Install With Any Combination of:

- Radiant System / Heating and/or Cooling
- Room Fan Coil Units
- Ducted Air Handler
- Concealed Ceiling Fan Coil Units
- Indirect Water Heater Tank
- Solar Thermal or PV Integration Support

- Modular for "Stacking" up to Three Outdoor Units



Major Advantages Chiltrix Air-To-Water Heat Pumps



- Much higher efficiency. All other things being equal, it is not at all possible for a conventional split system to ever match the performance of a hydronic system. And Chiltrix holds a world's record for efficiency among all air to water heat pumps.
- Exceptionally quiet! Only 49 dB(a). Ultra-Eco friendly & high efficiency R32 refrigerant system with 67% lower GWP & zero ozone depletion compared to R410a.
- Heating, cooling, hot water, ductless, ducted, radiant – use any or all with the same high efficiency system.
- No refrigerant is ever inside the building envelope. Better health & safety, and future-proofs your infrastructure as new and even less safe refrigerants emerge.
- No HVAC license or refrigerant handling, can be installed by a plumber, etc. Unbalanced heating vs. cooling loads don't cause an efficiency loss. No line-set length limits.
- Highest reliability possible. Refrigerant circuit tested and sealed at factory. The installer uses no torches, vacuum pumps, or gauges. Eliminates the most common causes of HVAC failure – in the field charging errors or connections that eventually leak.
- DIY Legal. And we support it that way! Maybe not your thing, but it's comforting to know the system is simple enough for a good handyman to install.



Chiltrix Air-To-Water Heat Pumps



- World's Record Efficiency
- CX50: Capacity 3.5 Tons Cooling, 4.8 Tons Heating
IPLV EER 21.2 / COP 4.62 (SCOP 4.55)
- CX35: Capacity 2 Tons Cooling, 3.4 Tons Heating
IPLV EER 22.4 / COP 4.9 (SCOP 4.69)
- IPLV is Similar to SEER but is not SEER
- SCOP is Seasonal Average COP (for equivalent HSPF Multiply by 3.412)
- Acoustic Energy: Extremely quiet by comparison to others, for example CX35 dB(A)49 and CX50 dB(A)52
- R32 – Up to 10% more capacity, 7% more efficient, lower GWP & CO2, 40% less charge needed.





Chiltrix Air-To-Water Heat Pumps



Basic System Overview - Components

Best-Of-Breed Component Selection – All Key Components are OTS (Off The Shelf). But only from the absolute “TOP” shelf.

Compressor: Variable Speed Mitsubishi DC Inverter (Dual)

Outdoor Fan: Variable Speed Panasonic DC Inverter

Air Coil: MULTISTACK

Water Coil: SWEP BPHE

Valves: Emerson/Danfoss

Pump: Variable Speed WILO/Grundfos

Refrigerant: CX35 and CX50 use Eco-Friendly R-32

AHRI-Certified / CEC-Certified Title 24 / UL 60335-1-40 /
UL 60335-2-40 / CSA 22.2



CX50/CX35 also have IEC EN14825

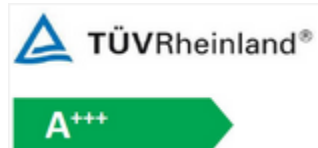

R32 has higher energy efficiency, with zero ozone depletion, and 67% lower global warming potential (GWP 675) than standard refrigerant R410a (GWP 2090). R32 allows higher capacity, uses less total refrigerant.



Chiltrix Air-To-Water Heat Pumps



CX Special Capacity Controls

1. Chiltrix is a load & capacity aware smart heat pump w/ variable speed inverter compressor & variable speed pump.
2. Uses leaving water temperature (LWT), entering water temperature (EWT) and flow rate to understand the load.
3. Automatically adjusts compressor speed/capacity to match the load.
4. Automatically adjusts pump speed to enforce a 9F delta.
(2.66 to 2.96 GPM per ton of capacity)
5. Set point is always based on return temperature.
6. Under steady state operation, LWT will be EWT plus 9F.
7. Other controls:
 - Dynamic Humidity Control - Optional
 - Dynamic Backup Heat Control - Included
 - Dynamic Outdoor Reset Control - Included
 - Radiant Cooling Controller - Optional



Air-To-Water Heat Pumps & IPLV & SEER



There is no such thing as SEER under the AHRI 550/590 air to water heat pump test and certification standard, no air to water heat pumps have a SEER rating. Under AHRI 550/590 a very similar metric is used for seasonal average EER, called IPLV (Integrated Part Load Value). Here's how it works:

Per AHRI, a properly sized air to water heat pump system needs to run at 100% about 1% of the time, runs at 75% capacity about 45% of the time, runs at 50% capacity about 42% of the time, and runs at about 25% capacity 12% of the time. IPLV uses a weighted average of EER at each of these conditions. Below is the AHRI formula for IPLV:

- $IPLV = 0.01 * A + 0.42 * B + 0.45 * C + 0.12 * D @ 44 \text{ } ^\circ\text{F LWT}^*$
(NPLV uses the same formula, at 54 °F LWT*)

*LWT=Leaving Water Temperature
(Supply temp, leaving the heat pump)

Where:

A = COP or EER @ 100% Load

(About 1% of the time the unit needs to run at around 100% capacity).

B = COP or EER @ 75% Load

(About 42% of the time the unit needs to run at around 75% capacity).

C = COP or EER @ 50% Load

(About 45% of the time the unit needs to run at around 50% capacity).

D = COP or EER @ 25% Load

(About 12% of the time the unit needs to run at around 25% capacity).



Air-To-Water Heat Pumps & COP, SCOP & HSPF



As with SEER, there is no such thing as an HSPF for air to water heat pumps. AHRI 550/590 does provide a heating test standard for full speed heating, but not for seasonal average COP which is far more important.

Chiltrix sent it's CX35 and CX50 heat pumps to the European lab TÜV Rheinland for officially certified part load heating performance, called SCOP, tested to IEC EN14825. This standard has highly similar test conditions as Climate Zone 4 HSPF. CX35/CX50 are certified for use in Europe with A+++ rating.

SCOP (Seasonal Average COP) can be converted to its HSPF equivalent by multiplication using a factor of 3.412.

$$\text{CX35 SCOP} = 4.69 = \text{HSPF } 16$$

$$\text{CX50 SCOP} = 4.55 = \text{HSPF } 15.5$$

What does it all mean?
 SEER = Seasonal Energy Efficiency Ratio
 HSPF = Heating Seasonal Performance Factor
 SCOP = Seasonal Coefficient of Performance
 EER = Energy Efficiency Ratio (BTU/Watt-hour)
 COP= Coefficient of Performance (W/W)
 1Wh = 3.412 BTU
 1 BTU = .2931 Wh
 Wh is energy = 1 Watt of power for 1 Hour
 BTU is energy = 1 BTU/h for 1 hour



Note – SCOP is not HSPF and air to water heat pumps cannot have an official HSPF rating. While ASHRAE has the same definition for both HSPF and SCOP, i.e., “the total heating output of a heat pump during its normal annual usage period for heating, divided by the total electric energy input during the same period”, the testing standards are not identical. SCOP is calculated as Watt-hours/Watt-hours and HSPF is calculated as BTU/Watt-hours. There are 3.412 BTU per watt-hour. Therefore, SCOP and HSPF can be used for performance modeling with the conversion factor of 3.412.



Psychrologix™ Controller



Optional Chiltrix Psychrologix™ Controller w/ Dynamic Humidity Control (DHC)

- DHC manages dehumidification (Latent heat rejection) & disables dehumidification when it's not needed.
- Can provide >37% additional energy savings above the official IPLV EER rating when dehumidification is disabled. (Leaving water temp 44F changes to 54F)
- DHC sensor monitors indoor relative humidity.
- Increased EER when running in >= NPLV conditions (Leaving water temp >= 54F) (similar increase in EER as is experienced with radiant cooling)
- Chiltrix CX34 official IPLV is EER 22.21
- When DHC is active, NPLV is EER 30.7 or higher
- When DHC is active, efficiency can be as high as EER 35
- Prevents Over-dehumidification
- SAVES ENERGY



$$W = \frac{Q_1}{COP_p} = \frac{Q_1(T_1 - T_2)}{\eta_{mech} T_1}$$

This is the Carnot efficiency equation for heat pump heating and cooling. What it means: When you lower the delta between the outdoor air and the leaving water temperature of the heat pump, the efficiency rises. That's why NPLV EER is higher than IPLV EER.



Humidity Control Psychrologix™ Controller w/ DHC



- In a standard AC/cooling system, the unit has no control over the coil temperature - “it is what it is”. Only Chiltrix patent-pending Psychrologix w/ DHC (Dynamic Humidity Control) can proactively and dynamically control the operating coil temperature.
- When indoor humidity is in the “good” range (user defined), the Chiltrix w/ DHC runs at ~NPLV settings, saving a large amount of energy, above it’s record-setting IPLV EER rating. DHC prevents over-dehumidification and wasted energy, and is suitable for humid climates, dry climates, variable climates, server rooms, etc.
- If humidity is created or enters the space (from a door opening, hot shower, etc.) the DHC controller immediately sees the increase in humidity and shifts operation to its IPLV settings, well below the dew point, to get rid of the humidity. When the humidity is under control and stable, the Chiltrix air to water heat pump w/ Psychrologix Controller will slowly recover back to NPLV settings.
- That means that some of the time, the unit runs at its record-setting official IPLV EER rating. At many other times, when indoor humidity is under control, Chiltrix unit can run with an enhanced EER up to 37% higher than it’s normal record-setting EER rating.



Psychrologix™ Controller



Below, the top chart shows IPLV, the bottom chart shows NPLV. Both are results from the official CX34 AHRI lab test and are based on identical ambient conditions.

The difference – IPLV shows cooling EER at loop (coil) temperature 44 °F (7 °C) w/ strong dehumidification active. NPLV shows cooling EER at coil temperature 54 °F (13 °C) w/ dehumidification reduced or disabled. Properly sized FCUs can still manage the sensible cooling load at NPLV (Dynamic Humidity Control Active) Conditions.

As you can see, running the loop 9 °F (5 °C) warmer has a profound effect on EER, increasing the average EER rating by over 37%. A few more °F increase can raise it as high as EER 35.

Published Performance	Evaporator Leaving Water Temperature, °C	Condenser Entering Air Dry Bulb, °C and % Load			
		35, 100%	27, 75%	19, 50%	13, 25%
Capacity, kW	7.00	7.500	5.625	3.750	1.875
Total Power, kW		2.381	1.187	0.5054	0.1959
Efficiency, COP (w/w)		3.150	4.740	7.420	9.570
IPLV.SI		6.510 kW/kw	EER 22.21		
Published Performance	Evaporator Leaving Water Temperature, °C	Condenser Entering Air Dry Bulb, °C and % Load			
		35, 100%	27, 75%	19, 50%	13, 25%
Capacity, kW	13.00	8.807	6.605	4.404	2.202
Total Power, kW		2.455	1.138	0.4085	0.1613
Efficiency, COP (w/w)		3.587	5.804	10.78	13.65
NPLV.SI		8.963 kW/kw	EER 30.58		



Compare Air-To-Water Heat Pumps



The chart below shows Chiltrix CX34 EER (Both IPLV and NPLV) compared to the top competitors. Update chart for CX35 coming soon.

Comparison of Chiltrix CX34 Chiller Performance with the Top Small Chillers (< 10 Tons)

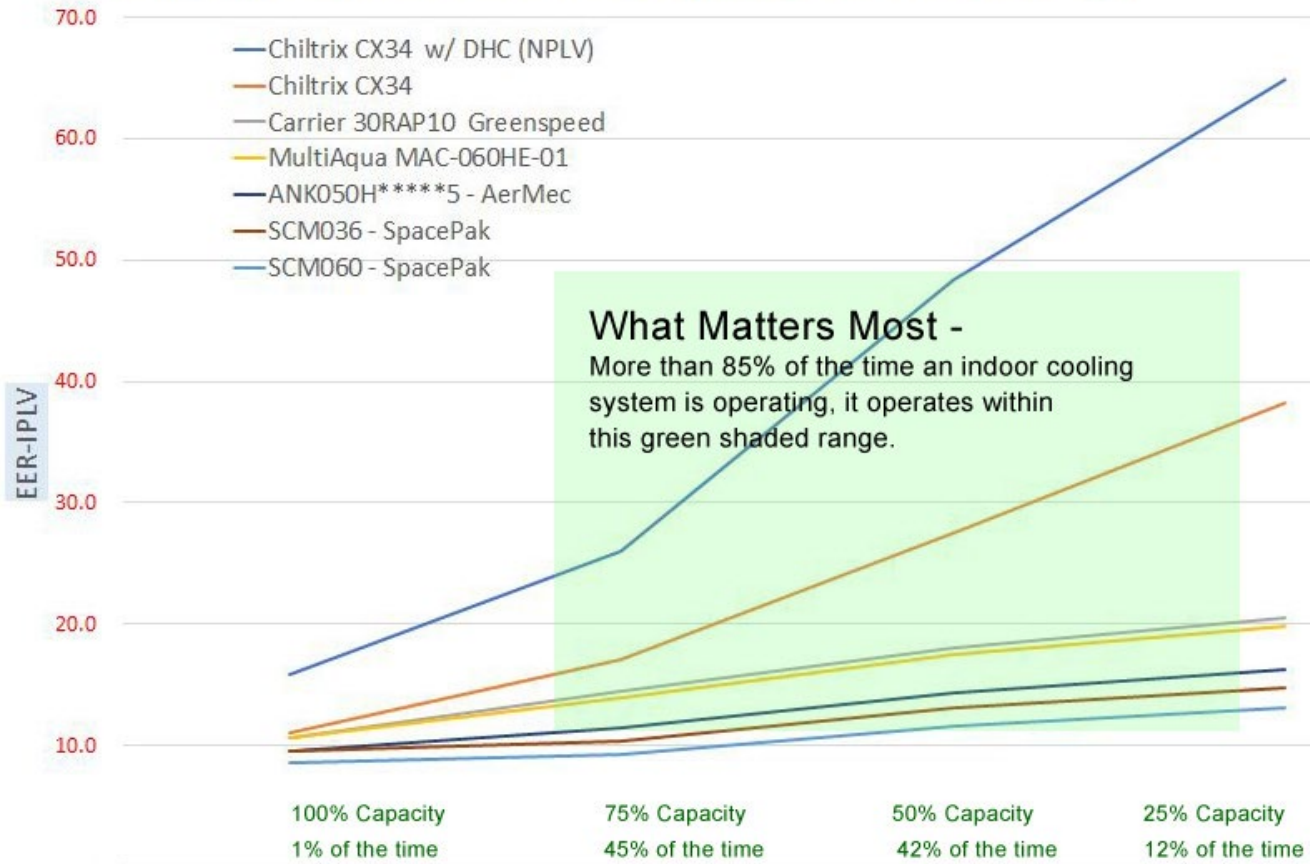

The top blue line shows Chiltrix running w/ DHC at NPLV.

What Matters Most -
More than 85% of the time an indoor cooling system is operating, it operates within this green shaded range.

The orange line shows Chiltrix running at its official IPLV.

These other lines show various competitors running at their official IPLV.

Only Chiltrix can dynamically shift between IPLV and NPLV.



Heating Operation



1. Heating control: As with cooling mode, capacity is controlled based on ΔT and GPM flow rate. Compressor and pump speed vary to match the load.
2. Typical running temperature of an air to water heat pump for radiant is 95 °F. Fan coil units should be sized for 104 °F entering water temp. Combo FCU-radiant design should be designed for 104 °F. Note that Chiltrix Fan Coil Units and Ducted Air Handlers are rated for 104 °F entering fluid temperature.
3. Radiant heating always requires a buffer tank. Small fan coil-only installations can often be run without a buffer tank with 15-20 gallons minimum loop volume.
4. Optional integrated V18 dynamically variable power backup heater targets an exact match to any heating shortfall and keeps compressor at full speed for higher net COP.
5. Onboard dynamic outdoor reset with user-customizable curve adjusts the target temperature dynamically according to outdoor temp. Allows higher Carnot efficiency (Higher COP) when the load can be met with a lower operating temp.



Heating Operation Proper Low-Temp Heating Design



1. With All Heat Pumps, “Lift” Drives the COP.
(Same as with IPLV Vs.NPLV)
2. Carnot Efficiency: $W = \frac{Q_1}{COP_p} = \frac{Q_1(T_1 - T_2)}{\eta_{mech} T_1}$
3. Lift = $T_1 - T_2$ (ΔT between ambient and supply temperature)



In-wall radiant (NREL)

4. Always design for the lowest possible heating supply temperature.

Example: at 0 °F outdoor temperature, an air to water heat pump such as the CX34 will have >20% higher capacity when used with an operating supply temperature of 95 °F compared to operating at 122 °F. And COP at 95 °F will be >30% higher than at 122 °F.

Help your customer get the highest COP: Use closer PEX spacing, faster flow rate, larger FCUs, add PEX in walls and/or ceiling if needed. Use the dynamic reset curve.



Heating Operation Proper Design



Radiant

Always design PEX (or panels etc.) for lowest operating temp, typically 90-104F.

AHU or Fan Coil Units

Size fan coils or air handler for 104F entering water. Check manufacturers data for capacity rating at non-standard water temperatures.

Always design indoor-side equipment for the lowest temperature possible.

See Heating Data on next slides.

See [reset curve development tool to create a custom curve](#)

$$W = \frac{Q_1}{COP_p} = \frac{Q_1(T_1 - T_2)}{\eta_{mech} T_1}$$

Carnot efficiency equation for a heat pump.

Dynamic Outdoor Reset Curve

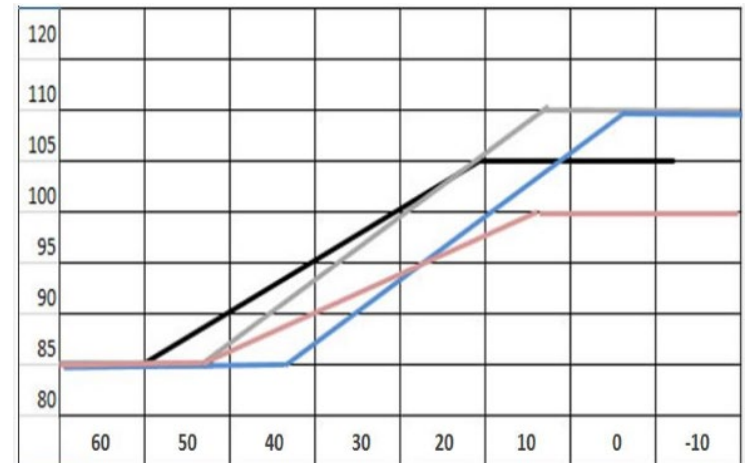

Design the indoor side of the system to handle the peak load at the lowest possible operating temperature, **then let the system automatically reset to a lower and even more efficient temperature at times when the weather is milder!**



Heating Operation CX50



Capacity and COP of a heat pump varies as a function of both outdoor ambient temperature and leaving water temperature. See Chiltrix CX50 heating performance map below.

Outlet Water Temp		Full Speed / Outdoor Air dB(wB)									
Temperature °F		-13	-4	5	17(15)	23	32	47(43)	59	68	77
86	Capacity	23,167	26,956	31,426	38,489	42,447	47,565	59,917	68,755	75,306	81,891
	Power Input	3.16	3.26	3.32	3.39	3.41	3.47	3.46	3.48	3.49	3.5
	COP	2.15	2.42	2.77	3.33	3.65	4.02	5.08	5.79	6.33	6.86
95	Capacity	22,416	26,069	30,880	37,636	40,536	45,347	56,983	65,752	72,269	78,820
	Power Input	3.32	3.43	3.48	3.54	3.56	3.58	3.61	3.66	3.7	3.73
	COP	1.98	2.23	2.6	3.12	3.34	3.71	4.62	5.26	5.73	6.2
104	Capacity	21,662	25,182	29,413	35,350	38,898	44,767	55,413	63,568	69,642	75,750
	Power Input	3.51	3.63	3.65	3.68	3.76	3.86	3.93	3.97	3.99	4.01
	COP	1.81	2.03	2.36	2.81	3.03	3.39	4.13	4.69	5.12	5.54
113	Capacity	NR	NR	28,423	35,555	38,625	43,710	54,219	61,623	67,151	72,679
	Power Input	NR	NR	3.99	4.1	4.13	4.19	4.28	4.32	4.35	4.37
	COP	NR	NR	2.09	2.54	2.74	3.06	3.71	4.18	4.52	4.87
122	Capacity	NR	NR	NR	33,439	36,715	42,174	53,809	60,156	64,865	69,608
	Power Input	NR	NR	NR	4.58	4.56	4.54	4.76	4.8	4.82	4.85
	COP	NR	NR	NR	2.14	2.36	2.72	3.31	3.67	3.94	4.21
131	Capacity	NR	NR	NR	34,804	37,261	41,321	50,704	57,051	61,794	66,537
	Power Input	NR	NR	NR	5.2	5.13	5.02	5.23	5.36	5.42	5.5
	COP	NR	NR	NR	1.96	2.13	2.41	2.84	3.12	3.34	3.55



Chiltrix Air-To-Water Heat Pumps



CX35 Seasonal Average Cooling EER Below
 :IPLV & Performance Map per AHRI 550/590 & SCC (Canada) ISO/IEC Standard 17065 /Type 4.

AHRI Official Performance	Evaporator Leaving Water Temperature, °F	% LOAD			
		100.00%	75.00%	50.00%	25.00%
Refrigeration Capacity, BTU	44.60	24,039	18,446	12,365	12,434
Total Power, W		2350.00	1200.00	480.00	340.00
Efficiency, Cooling EER (BTU/kW)		10.23	15.37	25.76	36.57
IPL		23.280	EER		

AHRI Official Performance	Evaporator Leaving Water Temperature, °F	% LOAD			
		100.00%	75.00%	50.00%	25.00%
Capacity, BTU	55.40	30,757	23,687	15,736	15,849
Total Power, W		2620.00	1222.00	430.00	270.00
Efficiency, EER (BTU/kW)		11.74	19.38	36.60	58.70
NPLV		32.590	EER		

CX35 Heating Performance map Full speed

CX35 Outlet Water Temp		Temperature °F								
		-4	5	14	17(15)	23	32	47(43)	59	77
86	Capacity	16,730	20,439	24,165	26,103	29,037	32,518	42,038	48,589	58,348
	Power Input	1.90	1.96	2.01	2.02	2.04	2.13	2.08	2.09	2.10
	COP	2.580	3.050	3.520	3.780	4.180	4.470	5.930	6.810	8.130
95	Capacity	16,139	19,893	23,646	25,113	27,365	31,119	40,468	46,815	56,300
	Power Input	2.07	2.17	2.24	2.27	2.30	2.35	2.42	2.35	2.28
	COP	2.285	2.687	3.094	3.242	3.487	3.881	4.901	5.839	7.237
104	Capacity	15,580	19,142	22,725	24,158	26,683	30,880	39,513	45,416	54,253
	Power Input	2.30	2.38	2.44	2.46	2.50	2.56	2.67	2.59	2.51
	COP	1.990	2.357	2.730	2.878	3.128	3.535	4.337	5.139	6.335
113	Capacity		18,613	22,315	23,817	26,035	29,754	38,182	43,812	52,206
	Power Input		2.59	2.63	2.64	2.66	2.68	2.76	2.79	2.81
	COP		2.107	2.487	2.644	2.869	3.254	4.055	4.602	5.445
122	Capacity			20,541	22,145	24,567	28,628	37,226	42,413	50,158
	Power Input			2.89	2.91	2.93	2.96	3.30	3.26	3.23
	COP			2.083	2.230	2.457	2.835	3.306	3.813	4.551
131	Capacity			18,767	20,507	23,134	27,502	35,793	40,741	48,111
	Power Input			3.3	3.3	3.32	3.34	3.66	3.75	3.86
	COP			1.67	1.82	2.04	2.41	2.87	3.18	3.65



Dynamically Variable V18 Backup Heater Patent Pending



- Typical ATW heat pump backup uses a water heater element in a buffer tank. The elements are either on at full power, or off. When backup heat starts, the typical system interprets this as a reduction of load and compressor slows or stops.
- Chiltrix with V18 is different. The V18 is instead controlled by the CX unit to target a BTU shortfall, dynamically matching its variable output in 1% power increments to precisely match any compressor heating capacity shortfall. Keeps compressor at full speed during backup heat operation for higher net COP.
- Heating element COP = 1.0 (Ohms Law)
Compressor COP = 1.7 to 4.9 (depending on conditions).
The more of the total heat that is provided by the compressor, the higher the overall efficiency will be.

The V18 can provide up to 18,780 BTU, multiple V18s can be used if needed. UL Listed components, requires assembly by a licensed electrician. Requires 30a GFCI breaker. Low pressure drop 0.000427775 ft. head.





Heating Performance Modeling



Below, see example CX34 COP & Capacity Chart showing 1x CX34, Windsor, Ontario, Canada WMO 712980 w/ Manual J Heating Load 24,000 BTU @ Outdoor Design 0 °F / LWT105 / Per AHRI 550/590 Heating Test Data

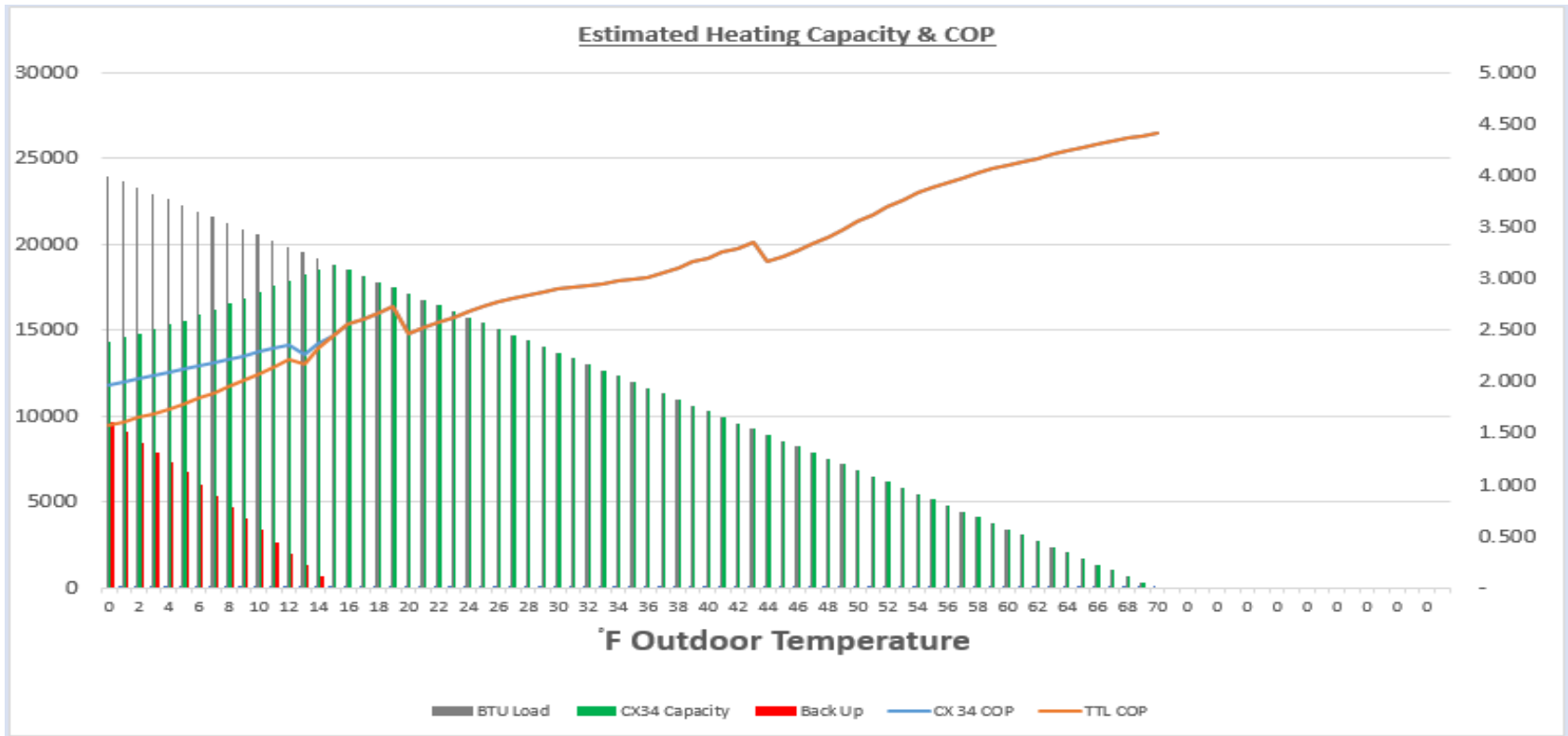

Vertical grey lines are the load, vertical green lines are heat provided by compressor, vertical red lines are heat provided by backup. BTU load is down the left side, COP is down the right side, and across the chart the orange line is TTL COP (net including backup heat at COP 1), blue line is compressor-only COP, outdoor temps are across the bottom.



Chiltrix Air-To-Water Heat Pumps Used w/ Fan Coil Units (FCU)



4 Sizes: 5.1" Thin Euro-Style Fan Coil Units

¼ ton, ½ ton, ¾ ton, 1 ton

DC Inverter Fan Motors – Nearly Silent

Universal Mounting – Low/Mid Wall, Floor, or
Ceiling

Sizing Considerations:

Select based on the higher of heating or cooling load.

Capacity rating depends on entering water temperature.

Designed for “wild coil” operation without valve.

Valve optional. WiFi Option Available.



For cooling, all fan coil units including CXI series are typically rated at 44 °F entering Temperature. Use Chiltrix CXI sizing guide for heating capacity.

Customers using the Psychrologix™ DHC (Dynamic Humidity Control) controller should size based on 54 °F or higher entering water temperatures.



Sizing FCUs



Cooling capacity performance data and curve

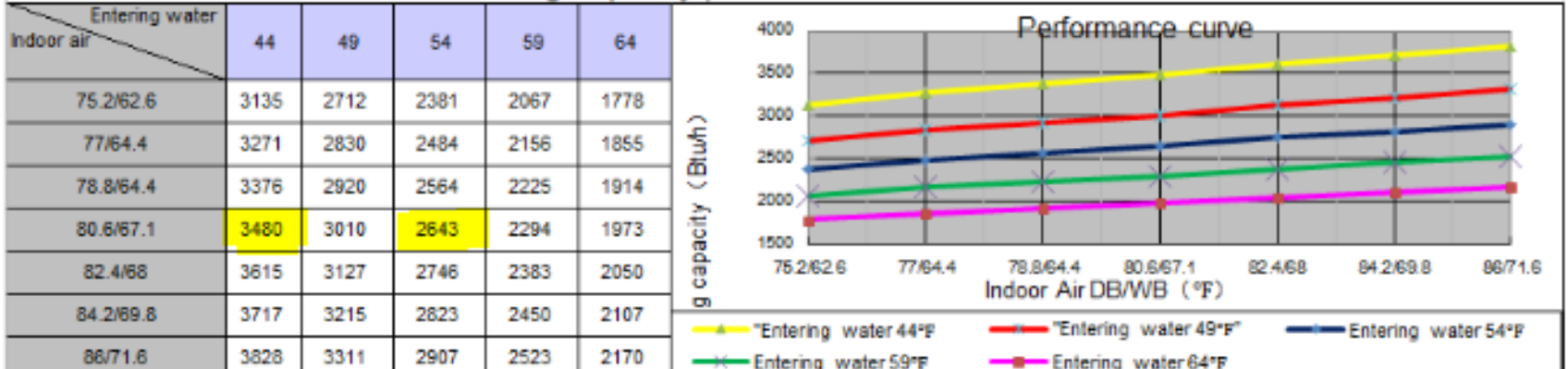

Heating capacity performance data and curve

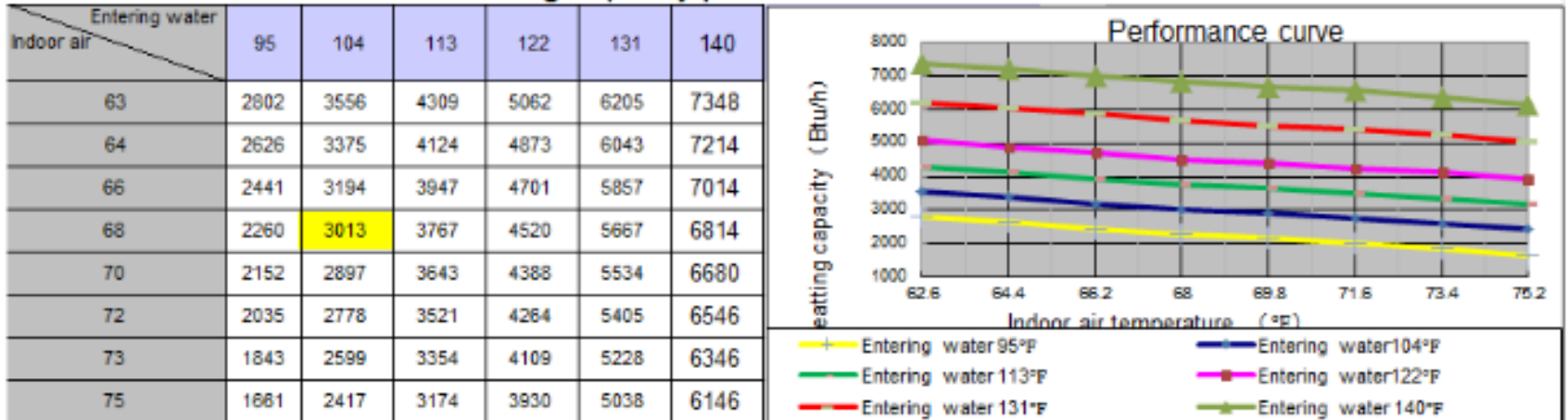

The yellow shaded areas are generally used for CXI sizing. For cooling, use the 44 °F for standard cooling. Use 54 °F column when using DHC controller. For heating, use 104 °F column. Complete sizing guide here <http://www.chiltrix.com/documents/CXI-capacity-test.pdf>



Sizing 3rd Party Air Handlers



Here is an example of a Unico Small Duct (Hi Velocity) Air Handler
 For cooling, always select based on 45F unless using Chiltrix Dynamic Humidity Control, in which case select based on 55F.

Entering Water Temp		Water Flow Rate		Airflow												Water Pressure Drop	
				500CFM (236 L/s)		600CFM (283L/s)		700CFM (330 L/s)		800CFM (378L/s)							
				Total Capacity		SHR	Total Capacity		SHR	Total Capacity		SHR	Total Capacity		SHR		
°F	°C	GPM	L/s	MBH	KW		MBH	KW		MBH	KW		MBH	KW		ft.	kPa
40	4.4	2	0.13	21.3	6.2	0.66	23.1	6.8	0.68	24.4	7.2	0.69	25.4	7.4	0.70	0.60	1.8
		4	0.25	25.3	7.4	0.63	28.1	8.2	0.64	30.3	8.9	0.66	32.3	9.5	0.67	1.80	5.4
		6	0.38	28.5	8.4	0.61	32.1	9.4	0.62	35.3	10.3	0.63	38.0	11.1	0.64	4.20	12.5
		8	0.50	30.1	8.8	0.61	34.5	10.1	0.61	38.3	11.2	0.62	41.6	12.2	0.62	7.20	21.5
45	7.2	2	0.13	18.1	5.3	0.70	19.7	5.8	0.72	21.0	6.1	0.74	21.9	6.4	0.75	0.60	1.8
		4	0.25	21.4	6.3	0.66	23.7	7.0	0.68	25.7	7.5	0.70	27.5	8.1	0.71	1.80	5.4
		6	0.38	24.0	7.0	0.64	27.1	7.9	0.65	29.7	8.7	0.66	32.1	9.4	0.67	4.20	12.5
		8	0.50	25.5	7.5	0.63	29.1	8.5	0.64	32.2	9.5	0.65	35.1	10.3	0.66	7.20	21.5
50	10.0	2	0.13	14.9	4.4	0.76	16.5	4.8	0.78	17.7	5.2	0.80	18.6	5.4	0.81	0.60	1.8
		4	0.25	17.3	5.1	0.72	19.3	5.7	0.74	21.1	6.2	0.76	22.7	6.6	0.78	1.80	5.4
		6	0.38	19.3	5.7	0.69	21.8	6.4	0.71	24.0	7.0	0.72	26.0	7.6	0.74	4.20	12.3
		8	0.50	20.5	6.0	0.68	23.4	6.8	0.69	25.9	7.6	0.70	28.2	8.3	0.71	7.10	21.2
55	12.8	2	0.13	12.0	3.5	0.85	13.5	3.9	0.87	14.6	4.3	0.89	12.8	3.8	1.00	0.50	1.5
		4	0.25	13.3	3.9	0.82	15.1	4.4	0.84	16.7	4.9	0.86	18.2	5.3	0.88	1.80	5.4
		6	0.38	14.5	4.2	0.79	16.5	4.8	0.80	18.3	5.4	0.82	20.0	5.9	0.84	4.10	12.3
		8	0.50	15.2	4.4	0.77	17.4	5.1	0.78	19.4	5.7	0.80	21.2	6.2	0.81	7.10	21.2



Sizing 3rd Party Air Handlers



Here is an example of a Unico Small Duct (Hi Velocity) Air Handler M3036CL1-C. For heating, generally select 105F for sizing. Below, the 105F values were interpolated from the manufacturers published data.

Entering Water Temp		Water Flow Rate		500CFM (236 L/s)		600CFM (283L/s)		700CFM (330 L/s)		800CFM (378L/s)		Pressure Drop	
				Total Capacity		Total Capacity		Total Capacity		Total Capacity			
°F	°C	GPM	L/s	MBH	kW	MBH	kW	MBH	kW	MBH	kW	ft. w.g.	kPa
95	35	2	0.13	10.7	3.1	11.7	3.4	12.5	3.7	13.1	3.8	0.4	0.1
		4	0.25	12.4	3.6	14.6	4.3	16.3	4.8	17.9	5.2	1.8	0.4
		6	0.38	12.4	3.6	14.9	4.4	17.1	5.0	19.0	5.6	3.9	1.0
		8	0.50	12.4	3.6	14.9	4.4	17.3	5.1	19.4	5.7	6.6	1.6
105	40.6	2	0.13	15.2	4	16.8	4.87	17.9	5.2	18.8	5.5	.4	.1
		4	0.25	17.4	5.1	20.6	6.0	23.1	6.8	25.3	7.4	1.8	.4
		6	0.38	17.4	5.1	20.9	6.1	24.0	7.1	26.7	7.9	3.9	1.
		8	0.50	17.4	5.1	20.9	6.1	24.3	7.1	27.2	8.1	6.6	1.6
110	43.3	2	0.13	17.5	5.1	19.3	5.6	20.6	6.0	21.7	6.3	0.4	0.1
		4	0.25	19.9	5.8	23.6	6.9	26.5	7.8	29.0	8.5	1.8	0.4
		6	0.38	19.9	5.8	23.9	7.0	27.5	8.1	30.6	9.0	3.8	0.9
		8	0.50	19.9	5.8	23.9	7.0	27.8	8.1	31.1	9.1	6.5	1.6
120	48.9	2	0.13	22.3	6.5	24.5	7.2	26.3	7.7	27.6	8.1	0.4	0.1
		4	0.25	24.8	7.3	29.5	8.7	33.2	9.7	36.4	10.7	1.8	0.4
		6	0.38	24.8	7.3	29.8	8.7	34.4	10.1	38.3	11.2	3.7	0.9
		8	0.50	24.8	7.3	29.8	8.7	34.8	10.2	39.0	11.4	6.4	1.6
140	60.0	2	0.13	32.2	9.4	35.5	10.4	38.1	11.2	31.8	9.3	0.4	0.1
		4	0.25	34.8	10.2	41.6	12.2	46.7	13.7	51.3	15.0	1.7	0.3
		6	0.38	34.8	10.2	41.7	12.2	48.4	14.2	53.9	15.8	3.7	0.9
		8	0.50	34.8	10.2	41.7	12.2	48.7	14.3	54.8	16.1	6.3	1.5



Domestic Hot Water



- DHW Function requires a heat exchanger tank (indirect coil or solar type tank) with a large coil surface area ($\geq .35 \text{ ft}^2$ per gallon).
- Requires a Chiltrix 3-way valve.
- When the DHW tank needs heat, the CX unit switches to DHW mode (Full Speed Heating) and switches the G1 to the tank. Space heating/cooling are paused temporarily and served by the buffer tank.
- Generally, the G1/tank should be close to the outdoor unit. A booster pump may be needed depending on piping design.
- Supported tank set point is 120 °F (Except when automated anti-legionella function is active).
- Optional backup heating element.

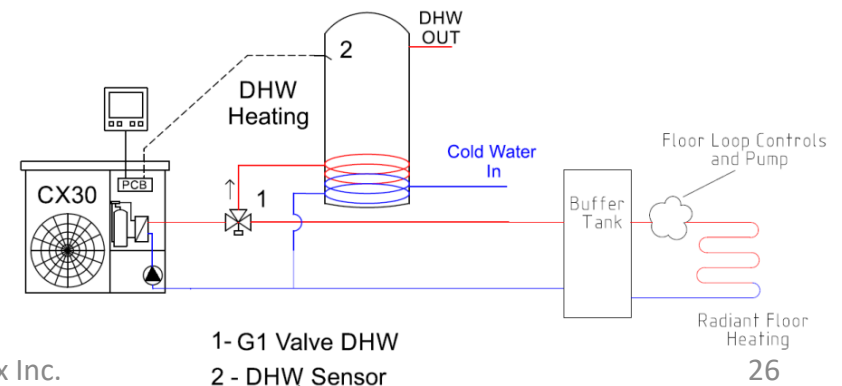



DHW Tank



DHW (Domestic Hot Water) Chiltrix DHW80:
 70 Gallons Net / Well Insulated Poly 50mm
 GIANT Coil: 72 ft. x 1.25" Convolved Coil
 32 ft² coil surface area
 Inner tank: Duplex 2205 Stainless Steel
 Outer Tank: 304 Stainless Steel

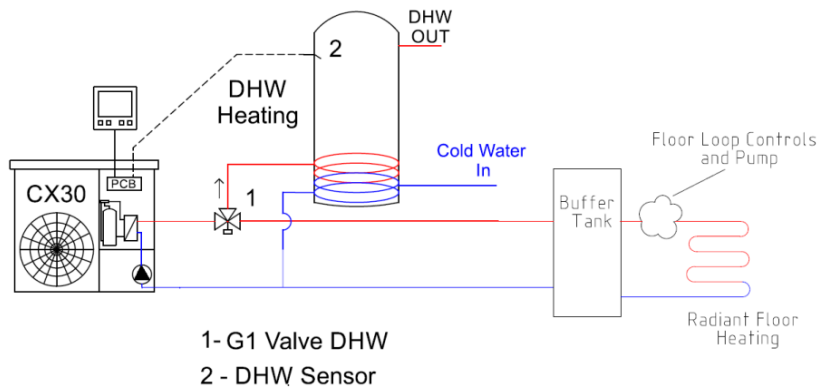
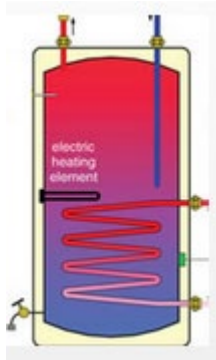



Buffer Tanks



VCT19 Buffer Tank: 304 Stainless Steel
19 Gallons Net / Well Insulated Poly 50mm
2x 1" NPT Ports Supply Side
2x 1" NPT Ports Load Side
Element-Ready For Emergency Heat

VCT37 Buffer Tank: 304 Stainless Steel
37 Gallons Net / Well Insulated Poly 50mm
6x 1" NPT Ports Side 1
4x 1.5" NPT Ports Side 2
Element-Ready For Emergency Heat
Designed For Either Vertical or Horizontal Installation

VCT60 Buffer Tank: 304 Stainless Steel
58 Gallons Net / Well Insulated Poly 50mm
6x 1.25" NPT Ports Side 1
4x 1.25" NPT Ports Side 2
Element-Ready For Emergency Heat
Designed For Either Vertical or Horizontal Installation



Use a VCT37 OR VCT60 when combining
2 or 3 CX34 OR cx50 Units.



CXRC Radiant Cooling Controller Prevents Unwanted Condensation



Siemens Mixing Valve & Actuator

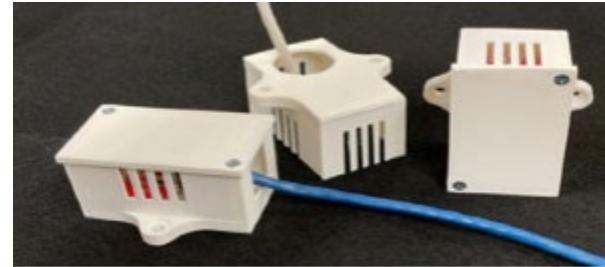

Dew Point Sensors

Dew point sensor rules:
1 per floor, up to 1600 ft²

IMPORTANT:
Let Chiltrix evaluate the application!

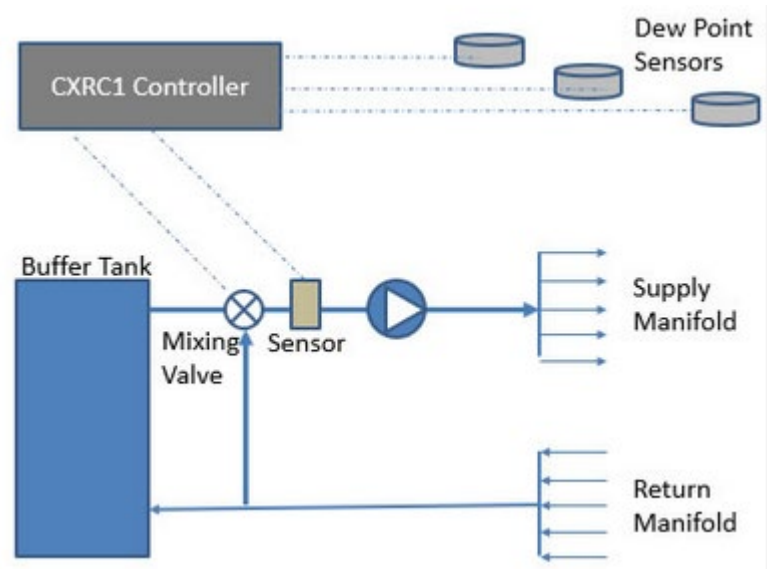

Advanced calculators available see <https://www.chiltrix.com/radiant-cooling/>



Chiltrix Air-To-Water Heat Pumps

Rebates & The Inflation Reduction Act

§18795a. High-efficiency electric home rebate program



Customers sometimes ask about rebates, incentives, etc. Chiltrix is approved under nearly every state program that offers incentives for air to water heat pumps including VT, MA, CT, CA. Chiltrix can and will qualify for others as they become available. At the federal level, there is no incentive for air to water heat pumps, except under the IRA (Inflation Reduction Act), see below.

<snip>

(A) Appliance upgrades

The amount of a rebate provided under a high-efficiency electric home rebate program for the purchase of an appliance under a qualified electrification project shall be-

- (i) not more than \$1,750 for a heat pump water heater;
- (ii) not more than \$8,000 for a heat pump for space heating or cooling; and

</snip>

<snip>

(B) Nonappliance upgrades

The amount of a rebate provided under a high-efficiency electric home rebate program for the purchase of a nonappliance upgrade under a qualified electrification project shall be-

- (i) not more than \$4,000 for an electric load service center upgrade;
- (ii) not more than \$1,600 for insulation, air sealing, and ventilation; and
- (iii) not more than \$2,500 for electric wiring.

(C) Maximum rebate

An eligible entity receiving multiple rebates under this section may receive not more than a total of \$14,000 in rebates.

</snip>

Pays 50% of the cost if customers annual household income is between 80% and 150% of the area median income; pays 100% if the household annual income is less than 80% of the area median income. Capped according to sections A & B at left.

The Inflation Reduction Act rebates are administered at the state level, consult with your state energy department. Chiltrix does not give tax or other financial or legal advice, or comment as to the applicability of any rebate for any particular user. Some rebates vary according to income and other qualifiers. The customer should contact their own tax/financial advisors for financial details.

From Title 42-THE PUBLIC HEALTH AND WELFARE CHAPTER 162-ENERGY INFRASTRUCTURE SUBCHAPTER V-ENERGY EFFICIENCY AND BUILDING INFRASTRUCTURE Part A-1-Residential Efficiency and Electrification Rebates.

Source: <https://uscode.house.gov/view.xhtml?hl=false&edition=prelim&req=granuleid%3AUSC-prelim-title42-section18795a&f=treesort&fq=true&num=0&saved=%7CSGlnaC1FZmZpY2llbmN5IEVsZWNOcmliEHvbWUgUmVlYXRl%7CdHJlZXNvcnQ%3D%7CdHJlZQ%3D%3D%7C1%7Ctrue%7Cprelim>



CX34 Air-To-Water Heat Pump (Shown w/ DHW, Optional V18 & Central Air Handler)

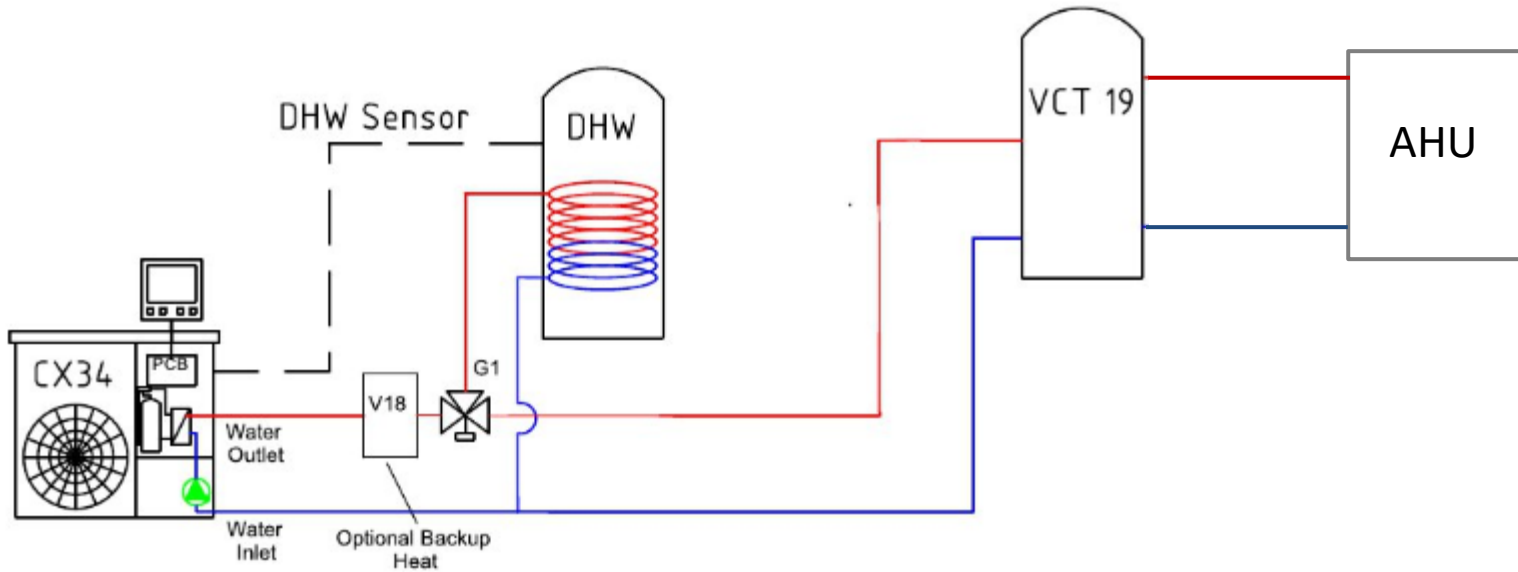

Simplified concept drawing –
not all components shown



CX34 Air-To-Water Heat Pump (Shown w/ Optional V18 & Radiant)



1,000's of possible designs

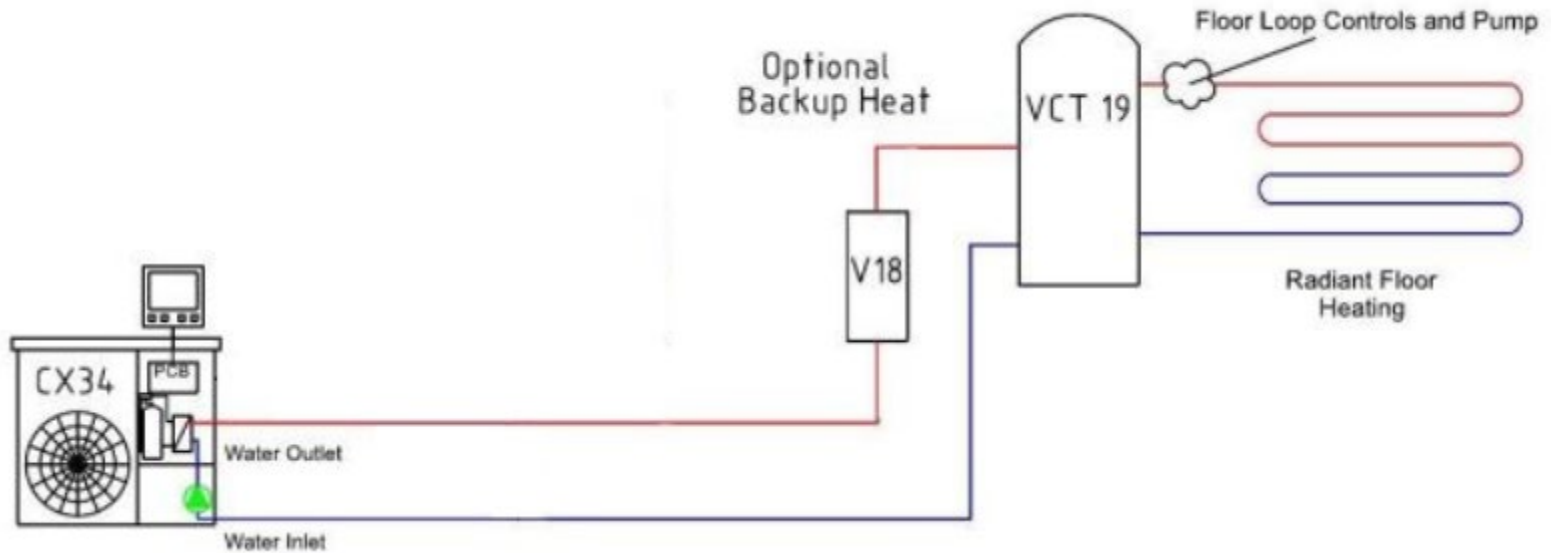

Simplified concept drawing –
not all components shown



CX34 Air-To-Water Heat Pump

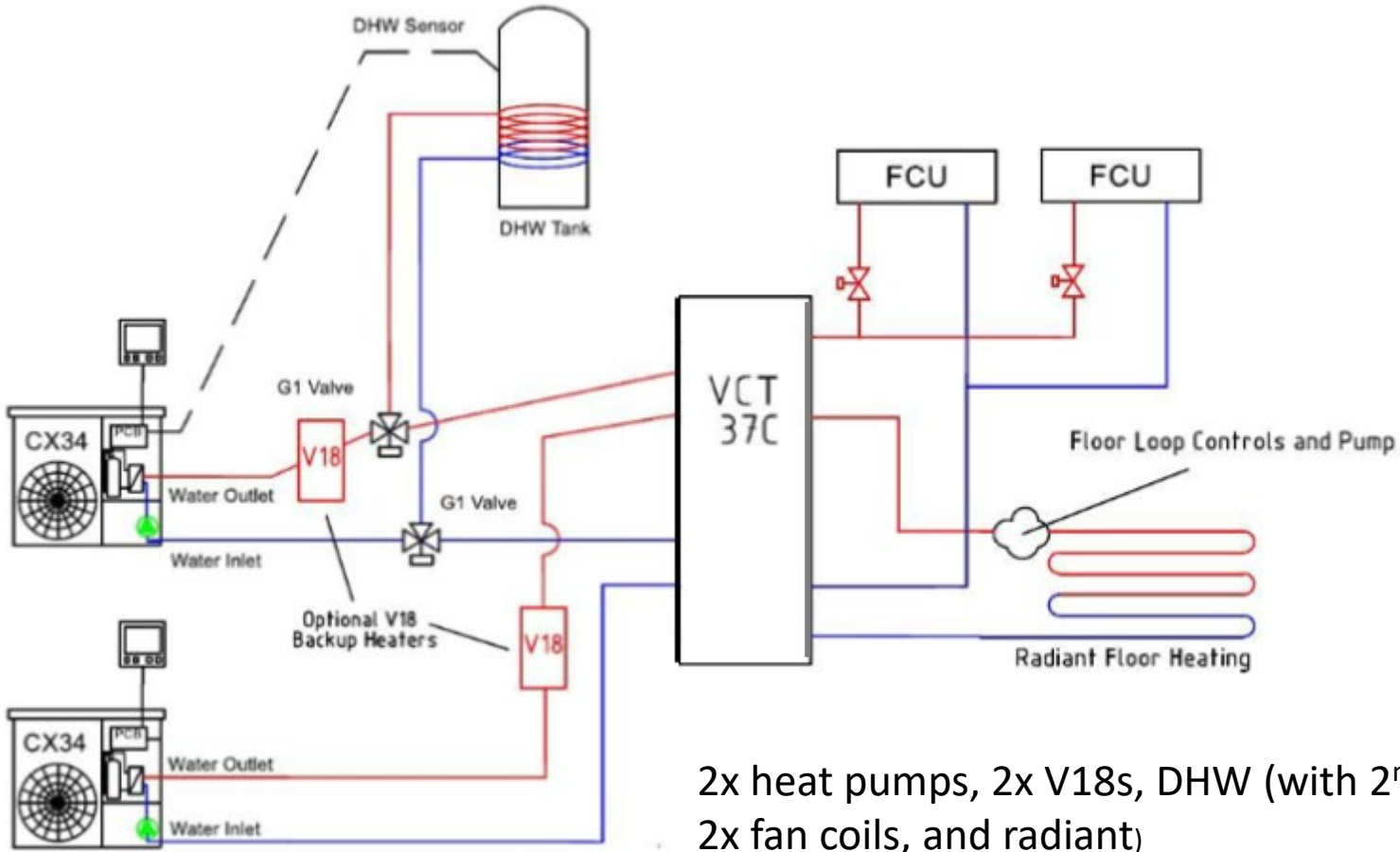

2x heat pumps, 2x V18s, DHW (with 2nd G1 valve),
2x fan coils, and radiant)

Simplified concept drawing – not all components shown



Design & Installation Notes



Compared to boiler powered systems, design is very similar but there are a few differences and some new things you will need to know. Chiltrix engineers are available to assist with designs & more. Please review the following items with Chiltrix in advance, as needed. We want to help! Let us be involved in your pre-sales, design, and commissioning!

A good design always starts with a Manual J or other heating & cooling load report.
IF YOU DO THE DESIGN YOURSELF PLEASE SEND THE REPORT & PIPING DESIGN FOR REVIEW.

- When a Buffer or Volume Tank is Needed
 1. Any time there is radiant.
 2. When the system will have less than 15-20 gallons of total fluid volume.
 3. Lots of annual hours at low loads (below 7kbtu heating/5kbtu cooling).
 4. Generally, it's always more efficient to use a buffer tank.

- Backup vs. Emergency Heat – What is the difference and how to use:
 1. Backup heat using V18 is applied “before” any loads and before the buffer tank.
 2. Emergency heat (elements in a buffer tank) may be manually activated in a case where the heat pump is unavailable.
 3. A boiler can be integrated by connecting directly to the buffer tank, Chiltrix can control the boiler. Let us help with the design.



Design & Installation Notes (continued)



- Operating Temperature vs. Capacity/Efficiency
 1. Always design for the lowest heating operating temperature.
 2. Generally, space the PEX as close as possible.
 3. Flow rates should be designed for lowest delta between supply and return.
- Using & Sizing Fan Coils/Air Handlers
 1. Chiltrix CXI fan coils and air handlers are designed for 105F entering water temp.
 2. All manufacturers can provide a 105F rating if requested, this temp should be used when sizing any fan coil or air handling units.
 3. If using DHC control, any cooling units should be sized to meet the load at 54 °F entering temp.
 4. Options: Wild coil, or valves and/or pump may be controlled by the CXI unit.
- Don't Use Primary/Secondary or Closely Spaced Tees on the supply side to combine multiple outdoor units. Use a Chiltrix multiport buffer tank (VCT37 or VCT60).

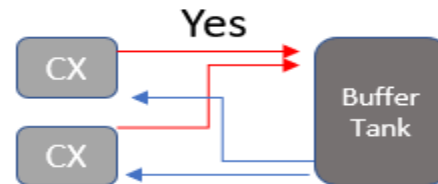
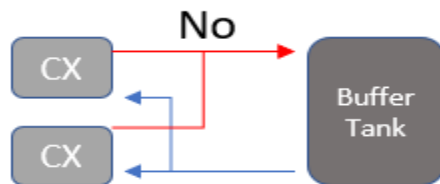

There are other options. If it is not possible to connect all outdoor units to the tank, contact us.

- Insulate all piping, taking special care for applications that will use cooling.



Chiltrix Air-To-Water Heat Pumps



Thank You!

John Williams
Chiltrix Inc.

More Questions? Please call or email:
john@chiltrix.com / 757-410-8640 Ext. 152

And please visit <https://www.chiltrix.com/>

ENERGY STAR 2019
Emerging Technology Award

