

Chiltrix

Thin DC-Inverter Water Fan Coil Unit Floor, Wall or Ceiling Universal Mount

Manual



Version 7.5 Updated 10-29-2024



CONTENTS

CHAPTER 1 GENERAL INTRODUCTION.....	3
1. Preface	3
2. Product Introduction	3
3. Measurements	3
4. Accessories	5
5. Product Features	6
6. Safety Precautions	6
CHAPTER 2 PERFORMANCE AND SPECIFICATIONS.....	7
1. Unit Measurements	7
2. Water Flow Rate and Water Pressure Drop	7
3. The working principle of CXI units	8
4. Installation Precautions	8
CHAPTER 3 INSTALLATION.....	9
1. Installation Precaution	9
2. Installation Position	9
3. Wall Mounted Installation	10
4. Mounting Bar and Water Hole Measurements.....	11
5. Water Pipe Connections	16
6. Condensation Lines.....	18
7. Ceiling or Horizontal Mounting	19
CHAPTER 4 MAINTENANCE AND OPERATION.....	21
1. Bleed Screws	21
2. Maintenance	22
3. Front panel operation	24
4. Parameter Setting	27
5. Remote Control.....	32
6. MD1001 Wiring Diagram	34
7. ZLFP10 Wiring Diagram.....	35
8. Standard Fan Coil Pump Wiring	36
8.5 External Control	37
9. Troubleshooting	38
10. Resistance Table	38
11. Parts Breakdown.....	39
12. Connections overview	40

CHAPTER 1 GENERAL INTRODUCTION

1. Preface

- Thank you for choosing the Chiltrix hydronic fan coil.
- The manual includes necessary information concerning correct installation, running and maintenance of units. Before installing or running machines, please carefully read this manual.
- When you are installing vertical water fan coil, connecting water circulation and wiring electric or electronic devices, please adhere to the instructions listed in this manual. Do not power on or test machines until installation is complete.
- Chiltrix reserves rights to change specification and design of units which may lead to content change of this manual.

2. Production Introduction

Vertical water fan coil is energy-saving and environmentally friendly equipment. It not only has compact structure, beautiful appearance, but also occupies little space and is easy to maintenance.

The vertical fan coil is not only for home, but also for hotels, offices and restaurant, wherever you need a comfortable climate.







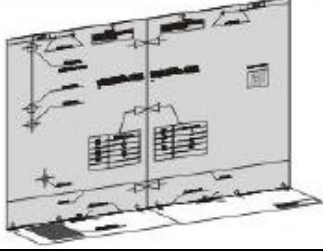

3. Measurements

Model	Net Dimension (inch: L/W/H)	Net weight / Gross weight (lb.)	Power Supply
CXI34	27.6 / 5.1 / 26.4	28.7 / 32	110V-1ph-60Hz
CXI65	35.4 / 5.1 / 26.4	37.5 / 41.9	110V-1ph-60Hz
CXI85	43.3 / 5.1 / 26.4	44.1 / 48.5	110V-1ph-60Hz
CXI120	51.3 / 5.1 / 26.4	50.7 / 57.3	110V-1ph-60Hz

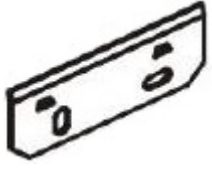

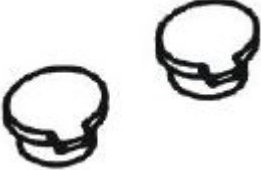
4. Accessories

The following assemblies are included in the box.

<p>Vertical Fan Coil</p> 	<p>Installation Template</p> 	<p>Drain Pipe</p> 	<p>Bracket</p> 
<p>Toggle Bolts</p>	<p>Screws</p>	<p>Screw Caps</p>	<p>Remote Controller</p>
			
<p>Feet</p>		<p>Bellows</p>	
			

Bellows are approximately 8"

IMPORTANT NOTES:

- 1.** If your shipment includes a mounting template, please note that it may potentially use the European model numbers - these may not match what you ordered. Please download the CXI templates or call Chiltrix support with any questions. Do not use any included templates unless you first verify the applicability. The correct CXI templates are here: <https://www.chiltrix.com/documents/chiltrix-cxi-fcu-installation-template.pdf>
- 2.** If you use the included transformers for operating a valve or starting a pump etc. note this is a 24vac .25a transformer. If used with a contactor or valve, then you will need to use a <.25a coil relay.

5. Product Features

- Extremely compact structure, attractive cabinet, and easy to transport.
- It can control the temperature both in summer and winter.
- Uses a DC fan motor combined with new air-guide technology makes for low noise operation.
- Our air exchanger (fin-coil) has a hydrophilic coating.
- All units undergo general and operational testing before they are prepared for shipping

6. Safety Precautions

Inspecting and Handling the Unit

After delivery, the package should be checked and any damage should be reported immediately to the carrier claims agent.

When handling the unit, please take into account the following:

- Fragile, handle the unit with care.
- Keep the unit upright to avoid damage.
- Move this unit with the original packaging.

Warning:

Fundamental rules should be followed when using a product that uses electricity and water such as:

Do not touch the appliance with wet hands or body when barefoot.

Do not clean appliance before disconnecting the electricity by turning the breaker off.

Do not modify or adjust the system outside of the manufacturers recommendations.

Do not pull on, knot or cut the electrical cables even if disconnected at the breaker.

Do not poke anything into the supply or return grills.

Do not leave the packaging materials within reach of small children.

Do not climb on the appliance or rest objects on it.

This appliance is not intended for use by persons (including children) with reduced physical sensory or mental capabilities, or lack of experience or knowledge, unless they have been given supervision or instruction concerning the use of the appliance by a person responsible for their safety. Children should be supervised to ensure that they do not play with the appliance.

If the power cord is damaged, it must be replaced and not repaired.

The appliance shall be installed in accordance with the NEC regulations.

CHAPTER 2 PERFORMANCE AND MEASUREMENTS

1. Unit Measurements (inches) Floor and Wall Installations

CX-34/65/85/120

Model	CX34	CX65	CX85	CX120
Dimension				
A	27.50	35.25	43.0	51.0
B	16	16	23.125	32
C	NA	23.125	32	38.875

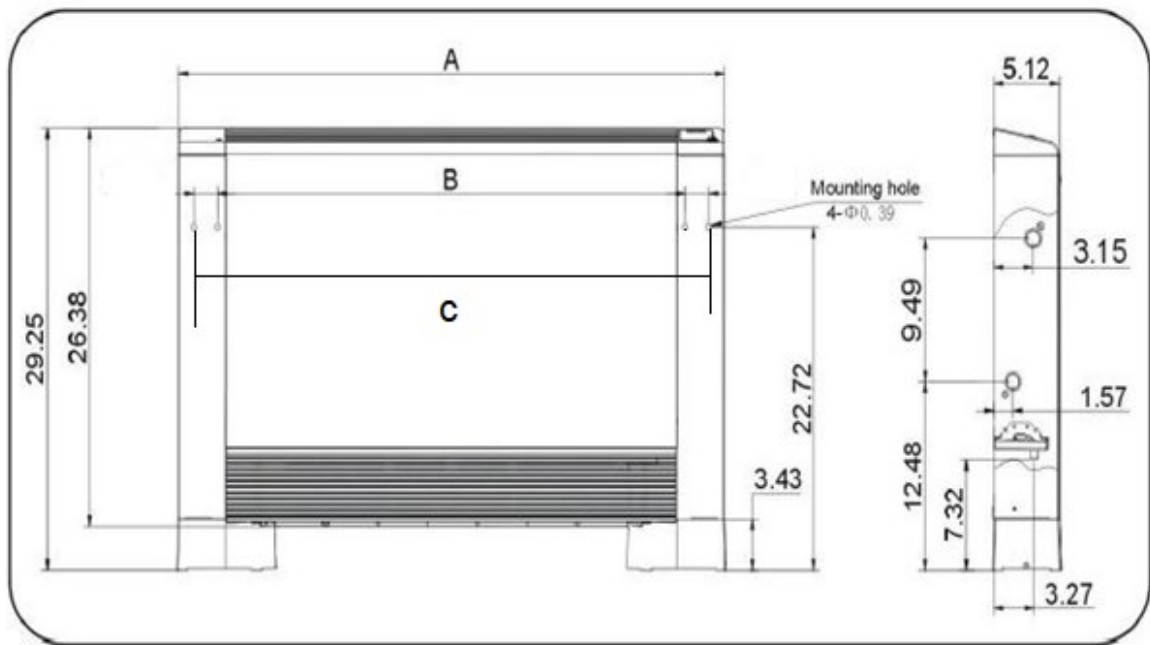

Water Flow Rate and Pressure Drop

Chiltrix Model	Cooling BTU	Heating BTU	Water GPM	Head Loss (Ft.)	Air CFM Volume	dB High	dB Low	Power Watts High	Power Supply
CXI120	11,877	9,727	2.4	9.3	340	39	28	22	115v 50/60Hz
CXI85	8,498	8,079	1.8	9.2	270	37	28	21	115v 50/60Hz
CXI65	6,451	5,666	1.6	4.4	188	32	27	18	115v 50/60Hz
CXI34	3,379	3,347	1.2	3.6	94	30	24	14	115v 60Hz

2. The working principle of CXI units

This Water Fan Coil is a terminal which uses water to provide heated air in winter and fresh cooled, dehumidified air in the summer.

Compared with the traditional fan coil, the newly designed Water Fan Coil is thinner, and quieter. It can be installed in various ways such as floor installation, wall installation, or ceiling installation, reducing the installation cost.

NOTE:

It is not required to install zone valves with our fan coils, the fan will simply shut off when the room reaches its set point.

3. Installation Precautions

- To ensure that the installation is performed correctly and that the Fan coil will perform perfectly, carefully follow the instructions indicated in this manual. Failure to follow the instructions will not only can cause a malfunction of the Fan coil but also invalidate the warranty and hence the manufacturer shall not be responsible for any damage to people, animals, or property.
- It is important that the electrical installation is performed according to national electric code, and the instructions in this manual are followed and the unit is correctly grounded.
- The fan coil must be installed in a position that allows routine maintenance, such as filter cleaning.

Positioning the unit

- Avoid installing the unit in proximity to:
 - positions subject to exposure to direct sunlight;
 - in proximity to sources of heat;
 - in damp areas or places with probable contact with water;
 - in places with oil fumes
 - places subject to high frequencies.
- Make sure that:
 - the wall on which the unit is to be installed is strong enough to support the weight;
 - the section of the wall chosen does not have pipes or electric wires passing through;
 - the selected wall is perfectly flat;
 - there is an area free of obstacles which could interfere with the inlet and outlet air flow;
 - the installation wall is preferably an outside perimeter wall to allow the discharge of condensation outside or a condensate pump may be used.
- Minimum clearances -----floor installation& wall installation, see page 11.
- Figure 1 indicates the minimum mounting distances between the wall-mounted cooler-convecter and furniture present in the room. See page 11.

CHAPTER 3 INSTALLATION

1. Installation precaution

- To ensure that the installation is performed correctly and the unit operates at optimum performance, carefully follow the instructions in this manual. Not following the instructions can cause malfunctions of the appliance and also invalidate the warranty. Chiltrix will not be responsible for any damage to persons, animals or property caused by improper installation or operation.
- It is important that the electrical installation is compliant with all NEC and local electrical codes.
- The appliance must be installed in a suitable position for easy access when cleaning the filter and general maintenance.

2. Installation position

The minimum distance from the floor to the lower line must be 3.25". The minimum distance of the air outlet grill from any possible obstacle must be 5.5". The minimum distance between side and side wall must be at least 1", to allow you to remove the cover.

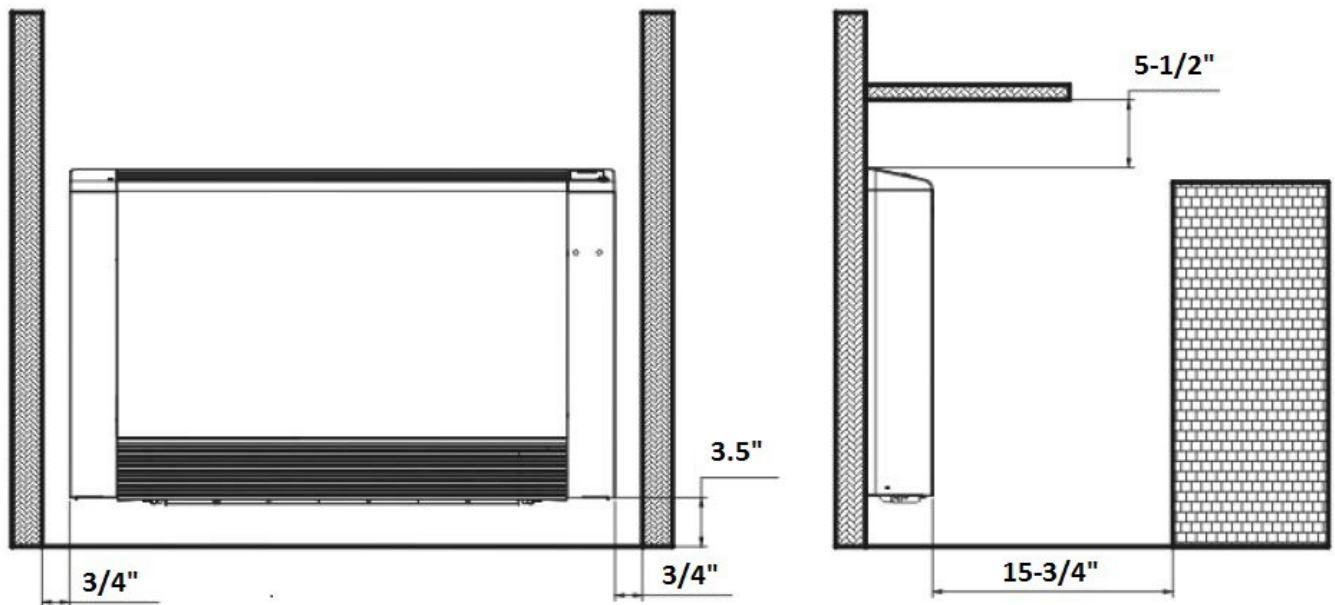
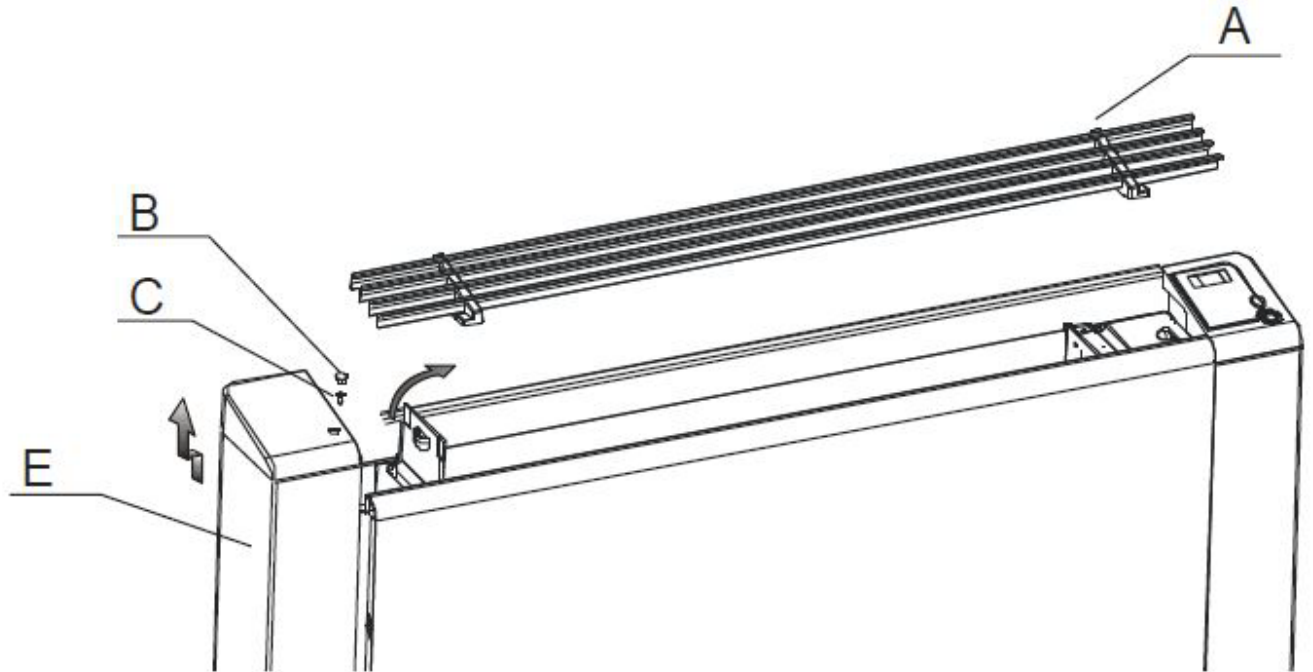

Figure 1

3. Wall mounted Installation

3.1 Removing the side panel (same procedure for both sides)

First remove the top grill (A), by removing the screws. Next take out the small rubber plug (B), and unscrew the holding screw (C). Then move the side (E), to the left, and lift the side upwards.



Wall installation or vertical floor mounts

Using the paper template [chiltrix-cxi-fcu-installation-template.pdf](http://www.chiltrix.com/chiltrix-cxi-fcu-installation-template.pdf), trace the position of the wall (fig.10). Drill the holes and insert the toggle bolts (2 for each bracket) (fig.11 ref. A); attach the bracket (fig.11 ref. B) included with the FCU.

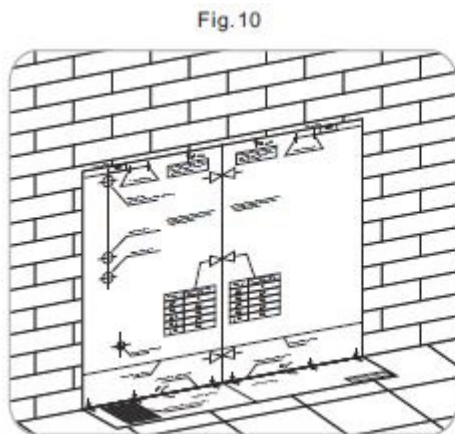

Fig.10

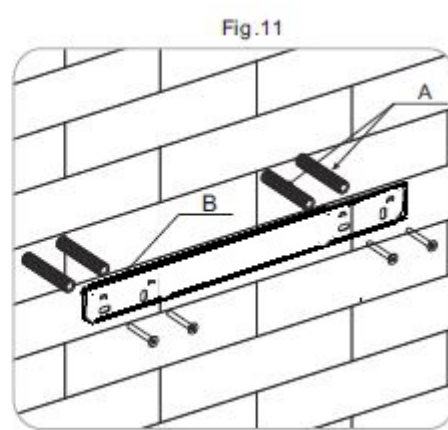
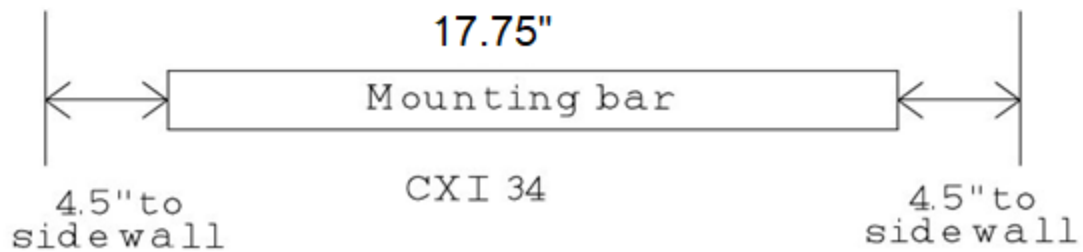
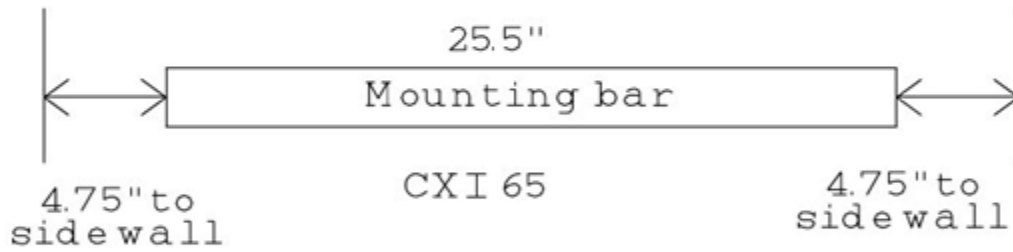
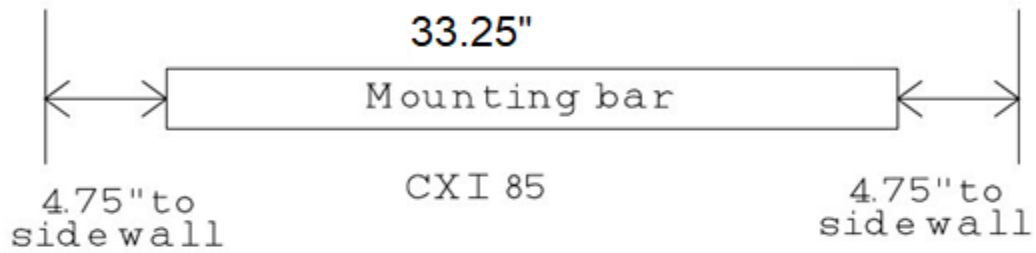
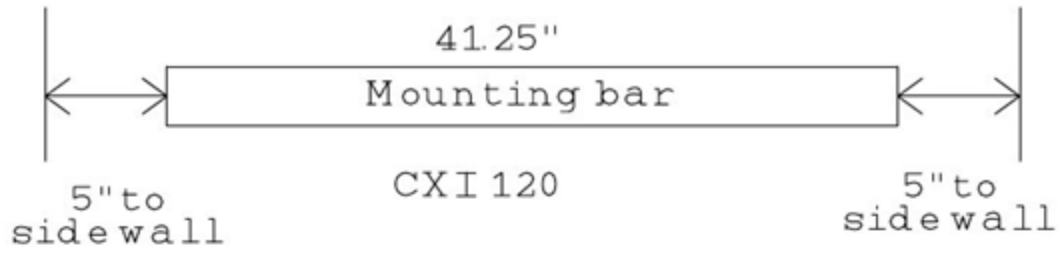
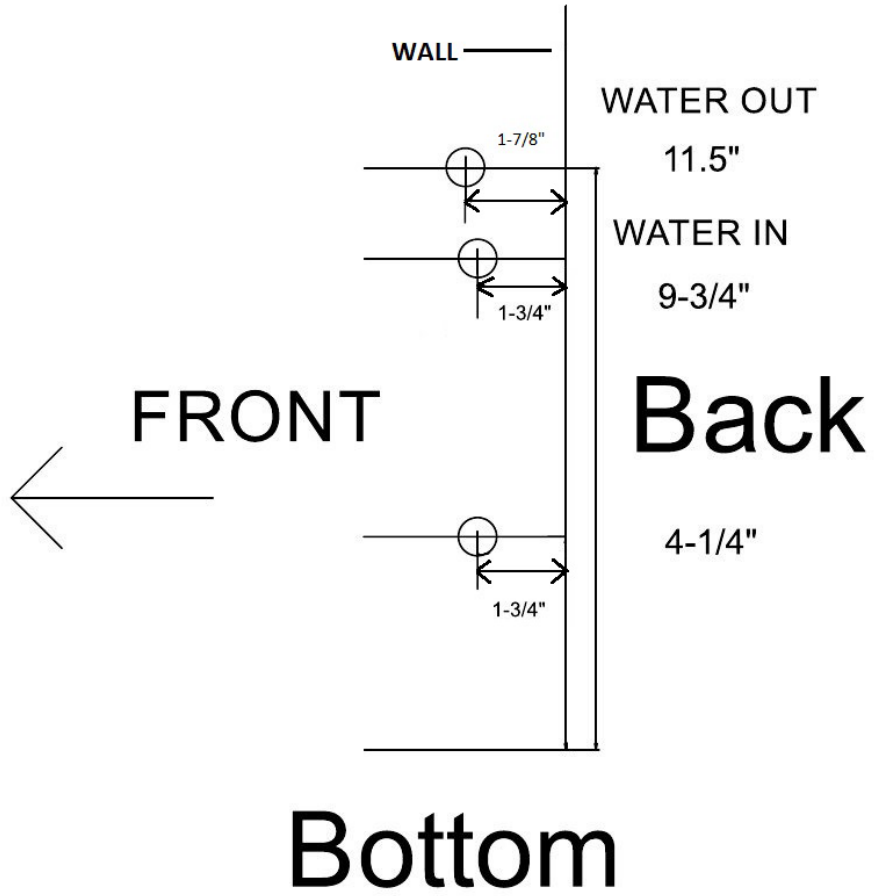

Fig.11

4. Mounting Bar and Water Hole Measurements





View From Left Side

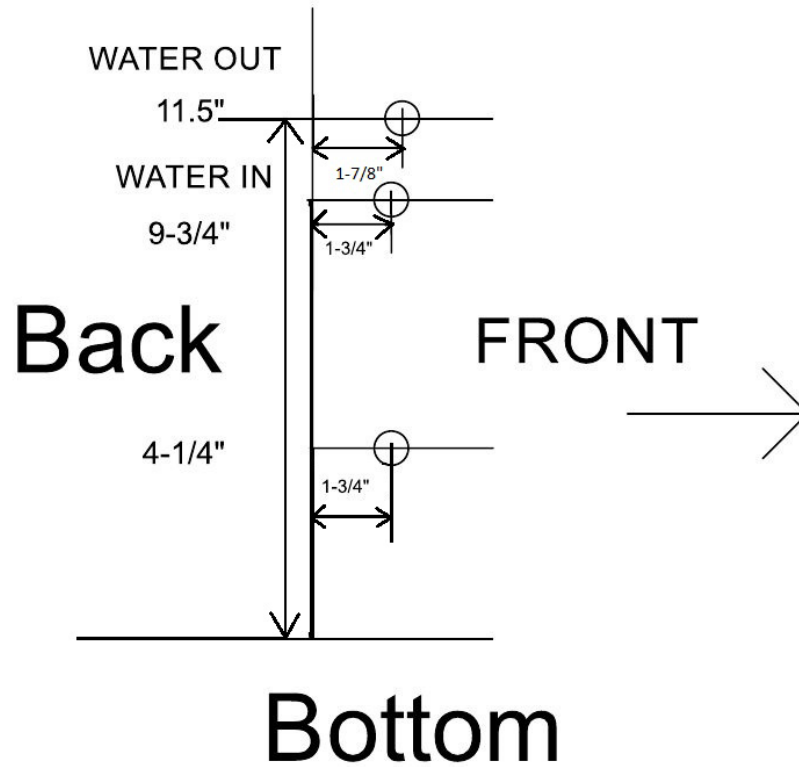

Before you install the unit on the floor, the feet should be mounted: First, lay down the unit, take out the screws and two feet from accessories bag, then line up the screw holes, and attach the feet with the screws. (See fig.12 and fig.13)

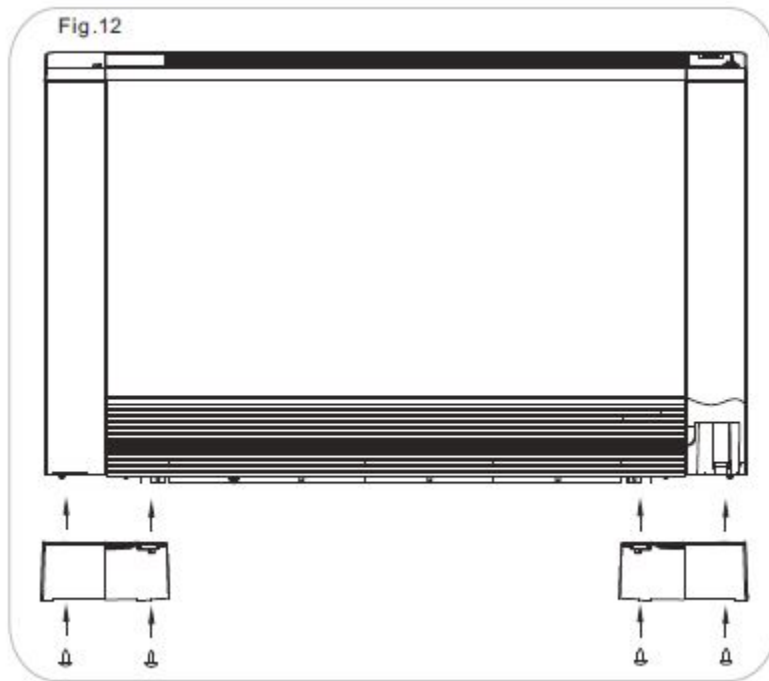

Figure 12 Installing the Feet

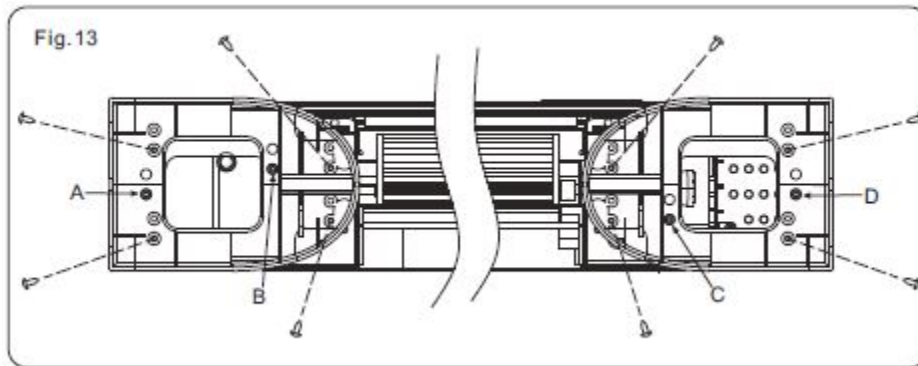

Figure 13

Do not over-tighten the screws so that the bracket can be adjusted with a spirit level (fig. 14). Then fully tighten the four screws to block the bracket.

Mount the unit, checking that it fits correctly onto the bracket and that it is stable. (fig. 15).

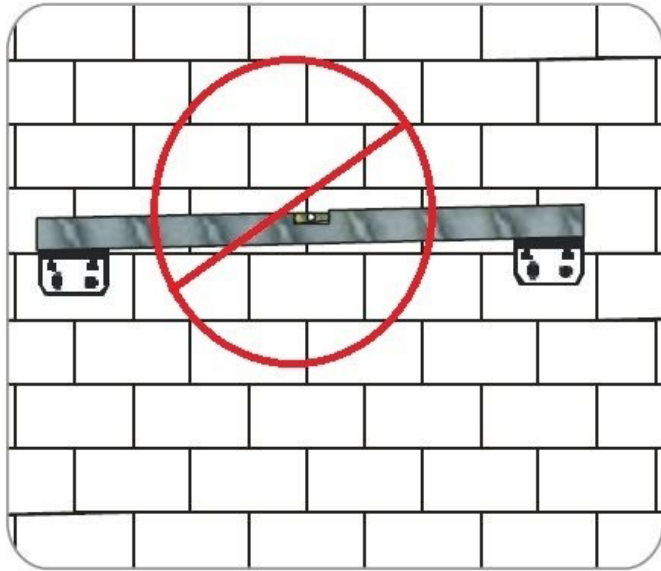

Figure 14

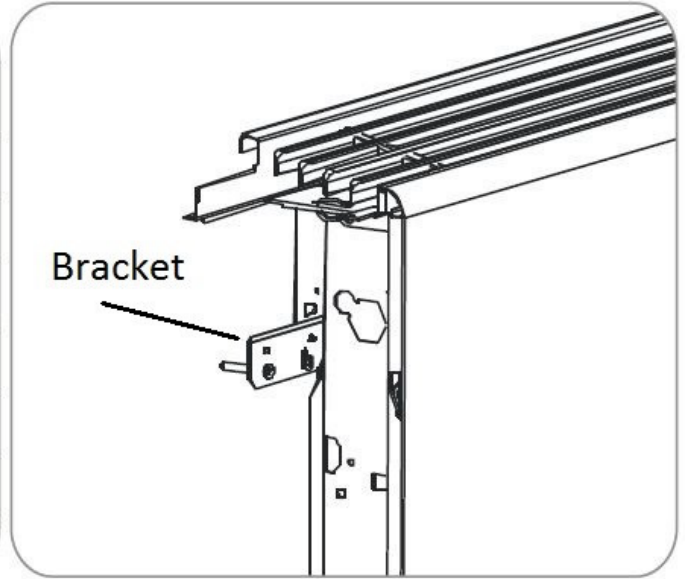
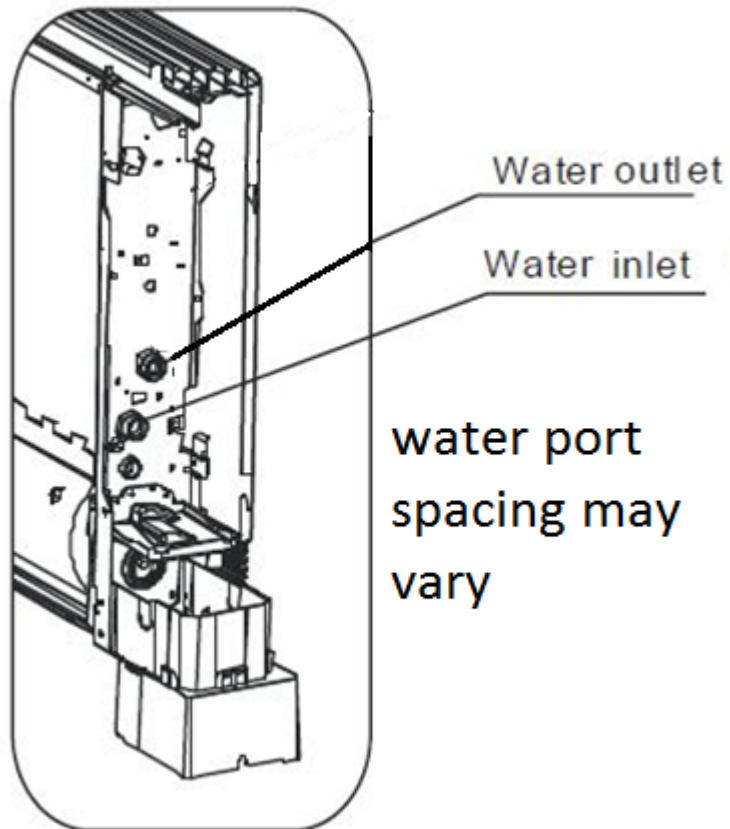

Figure 15

Water Connection floor installation& wall installation

To connect the inlet and outlet water pipes, refer to the figures below.



5. Water Pipe Connections



Fig. 20

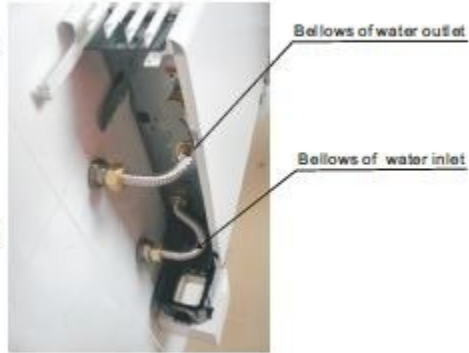
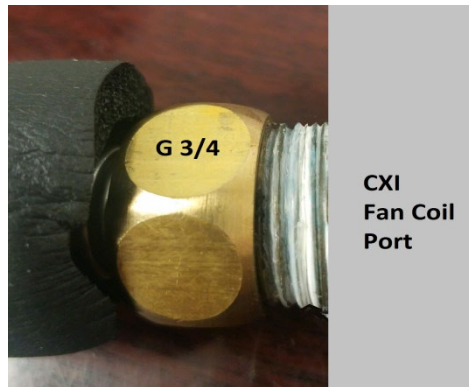

Fig. 21

The bellows shown are examples only, the bellows shipped are approximately 8" long.



Bellows NPT $\frac{3}{4}$ to fitting connection



Bellows G3/4 fitting to CXI port, use the white washer from the bag on this end.

Use blue monster 70885 PTFE thread seal tape or equivalent.

Installation tip for installing the white washers on the G3/4" side of the bellows.

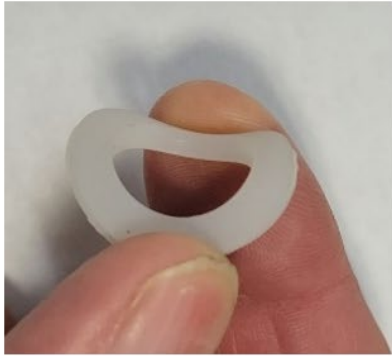

Flexible Washer



Apply silicone grease to one side of the washer



Insert washer into bellows with greased side facing out, install hand tight on fan coil

The newer style white flexible washers are softer than the previous version hard washers and can be deformed or torn when tightening if you are not careful.

We highly suggest to use silicone grease (NOT silicone sealer!) as shown above which will prevent deformation and/or tearing when tightening. You still need to be careful, do not over-tighten!

6. Condensation Lines

Condensate discharge

The condensate discharge network must be properly sized, (minimum inside pipe diameter 1/2 inches) and the piping must be positioned in such a way as to keep an inclination, of at least 1%. The drain pipe (C) is connected to the pan (B), positioned under the heat exchanger coil (A). If the condensate is discharged into the drainage system, it is recommended to install a p-trap to prevent any pipe smell from entering the rooms. The p-trap must be lower than the pan.

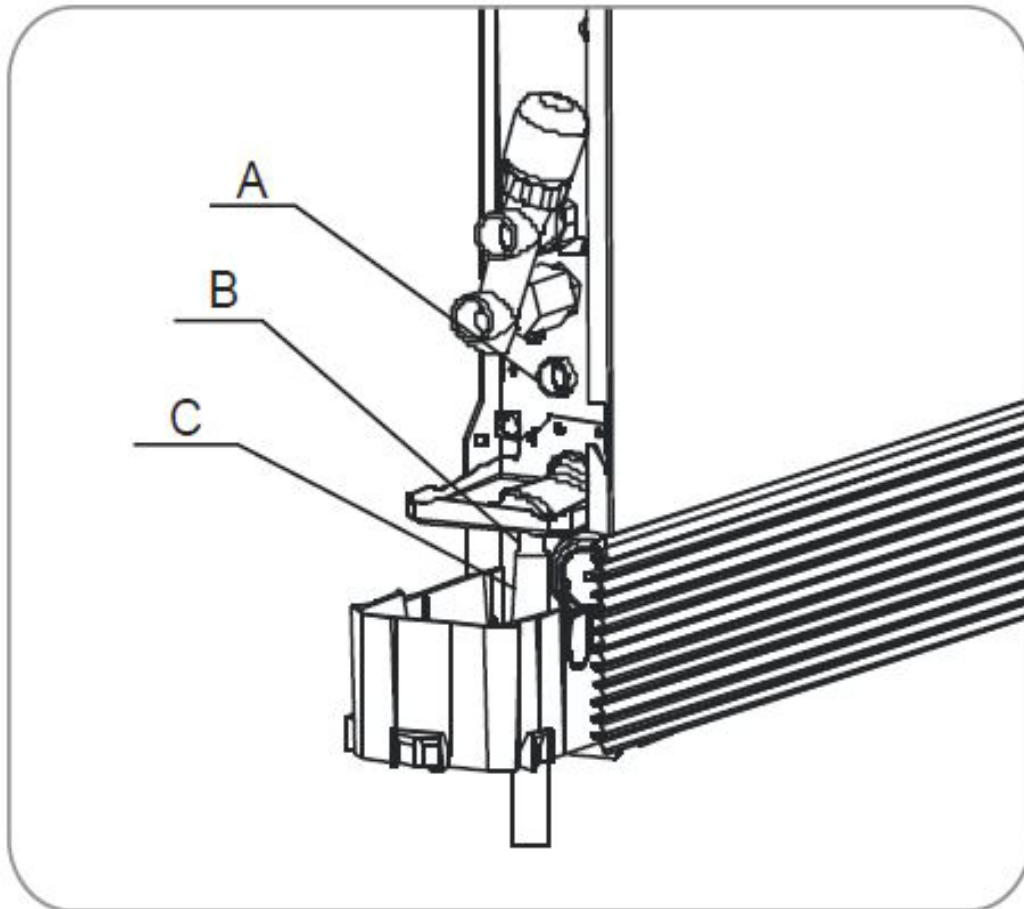

7. Ceiling or Horizontal Mounting

Minimum Installation Distances-----Horizontal Installation

Figure 24 indicates the minimum mounting distances between the wall-mounted Fan coil and furniture present in the room.

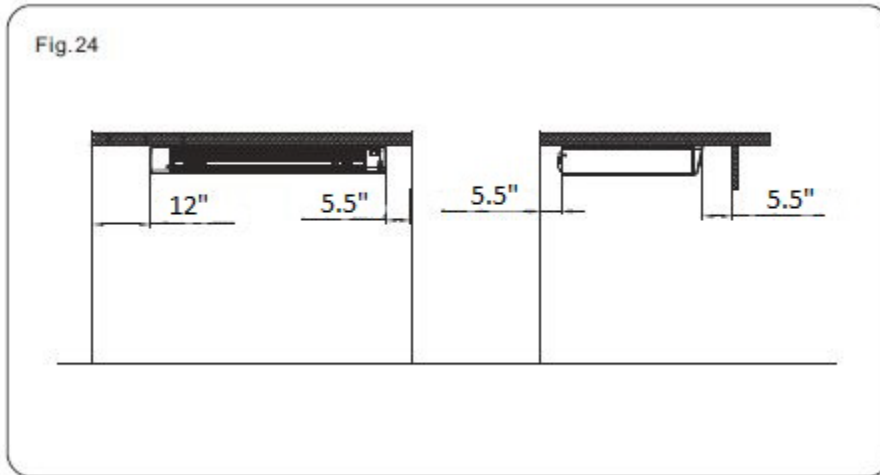

Side Opening

Lift the cover that protects the screw and remove the screw.
Move the side panel slightly and lift it out.

Ceiling of Horizontal Installation

Ensure that there is enough clearance around the unit, according to installation dimension chart (fig. 5 or fig.6). Mark the relative screw holes on the installation wall (fig. 26), then drill the holes, and then mount the unit.

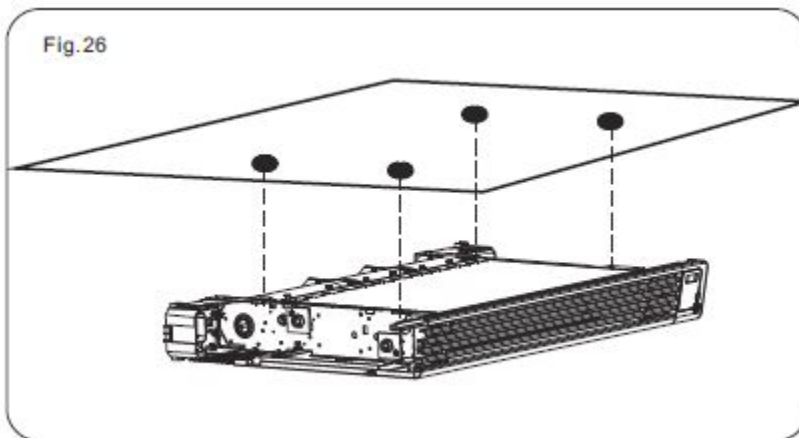

Adjust the unit so it is 1-2° tilts towards the condensation drain-pipe port for better condensation water draining.

Mount the unit, checking that it fits correctly on the bracket and it is stable.

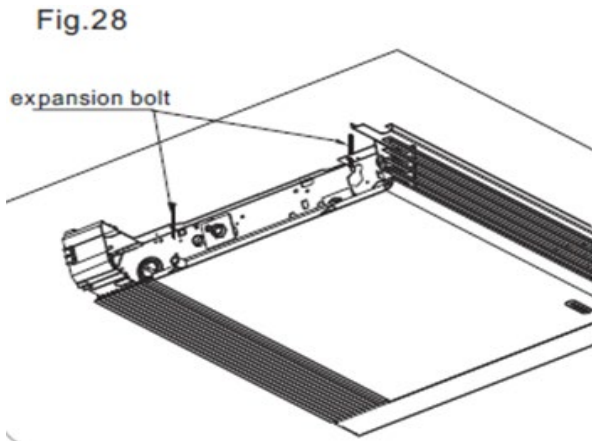

Condensation piping

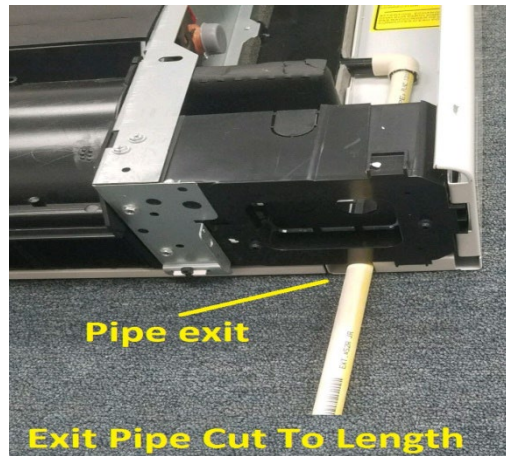

Connect a ½" CPVC elbow to the ceiling mount drain port, then using a ½" piece of CPVC pipe, extend the drain out the rear of the unit through the gap shown in the above picture.

CHAPTER 4 MAINTENANCE AND OPERATION

1. The following steps are taken after commissioning. These steps are for yearly maintenance and are not to be confused with flush/filling the system loop.

Evacuating air after filling and commissioning the system,
Use a screwdriver to unscrew the side breather valve (fig. 23 ref. A). When water starts coming out of the breather valve of the appliance, close it and continue filling until reaching the nominal value for the system. Check the hydraulic seal of the gaskets.
It is advisable to repeat these operations once every 1-2 years, also, periodically check the pressure of the system loop on the rear of the CX34.

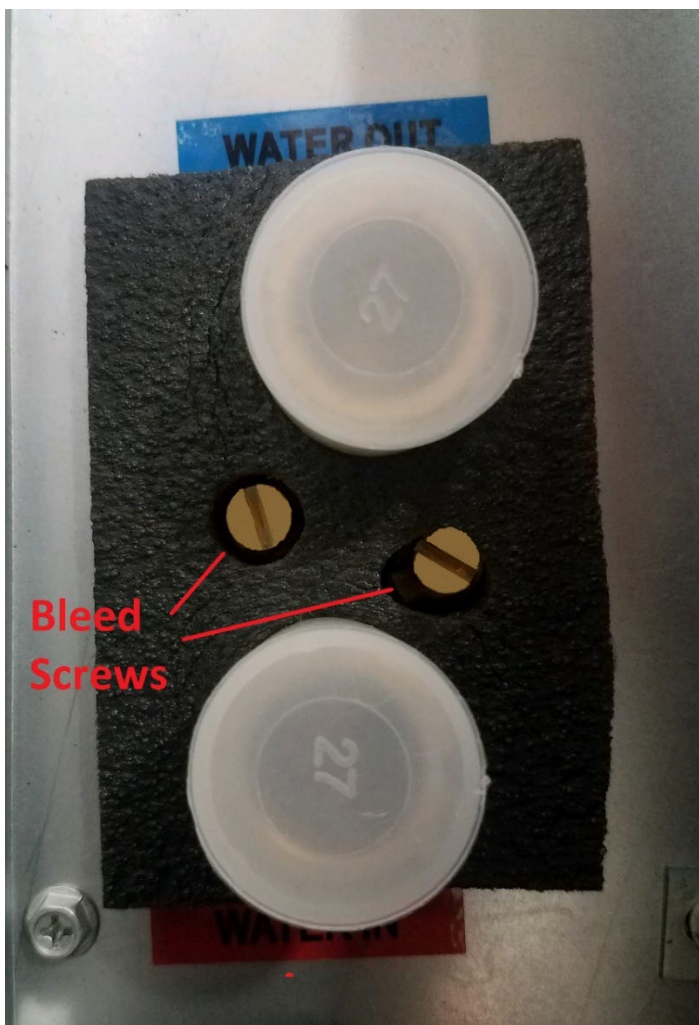

Bleed the air in the hydraulic system

Use a screw driver to loosen the bleed screw (A), and remove the air in the system.

2. Maintenance

Cleaning the Filter

To keep the unit problem free, it is suggested to maintain and clean the unit every six months. Please take the following steps to clean the strainer regularly:

- 1) Remove the plastic tape which is used to secure the air inlet grill during shipping. (A Fig.33)
- 2) Next, lift the grill upward about $\frac{1}{4}$ " (Fig.34), the grill will pop-up automatically. (Fig.35)
- 3) Remove the grill (Fig.36), and take out the strainer (Fig.37), the strainer can be washed with water. (Fig.38).
- 4) Replace the grill and strainer referring to (Fig.7).

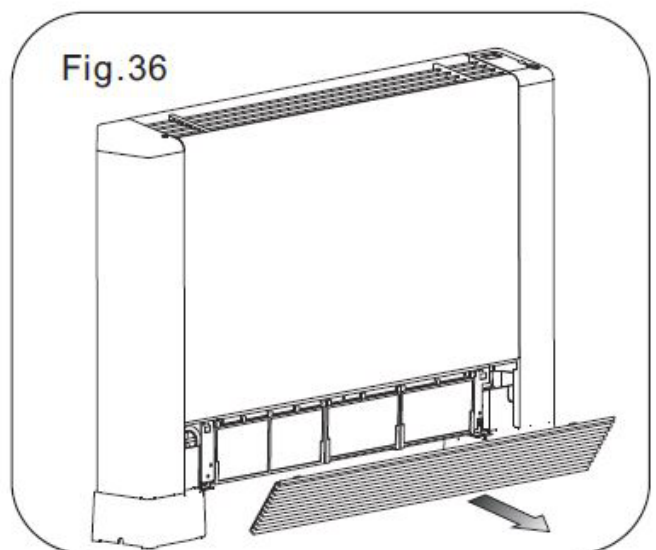
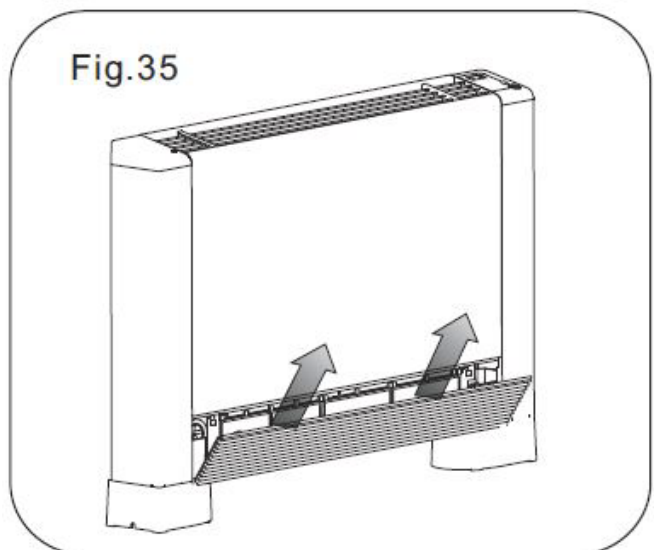
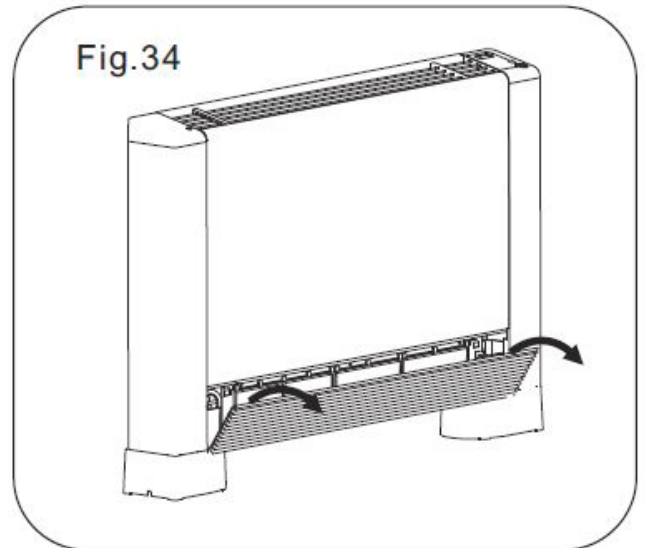
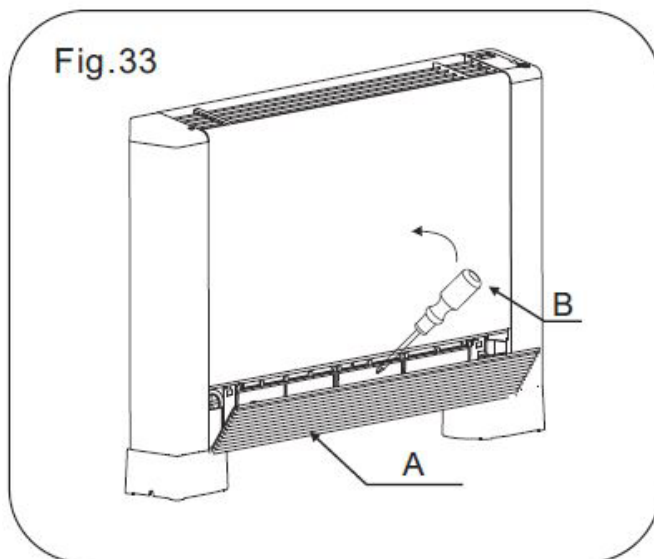

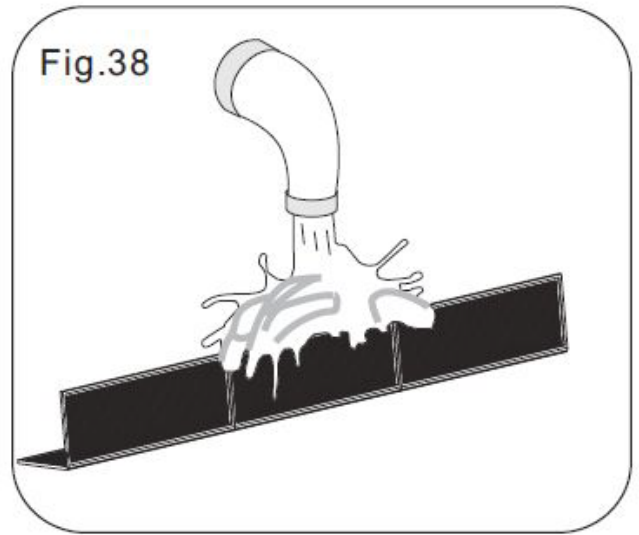
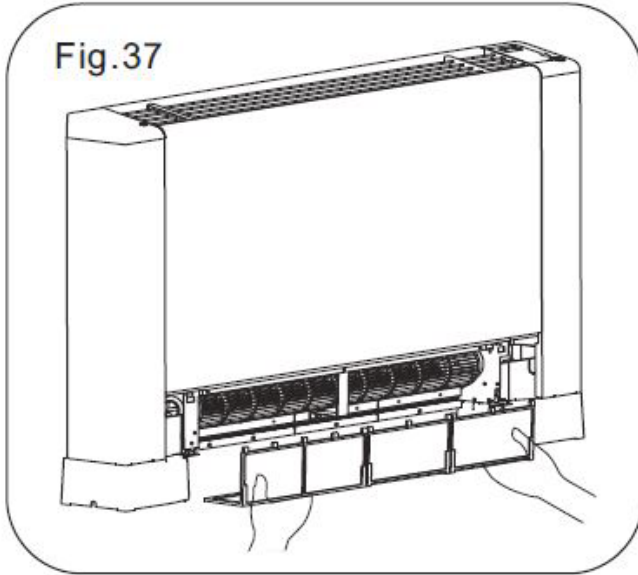

5) Set the filter net and the air return grille to the original place. (Fig.39).

6) Clean up the units outer cover with a soft damp rag (Fig. 40) . To protect the paint, use a mild detergent.

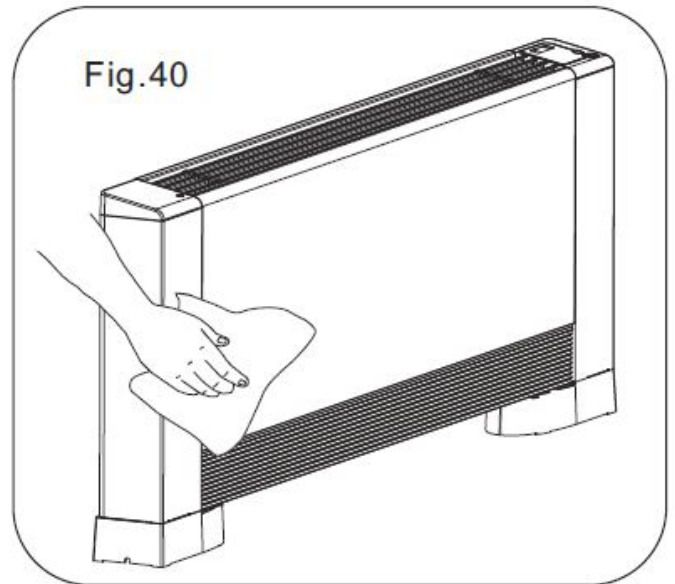
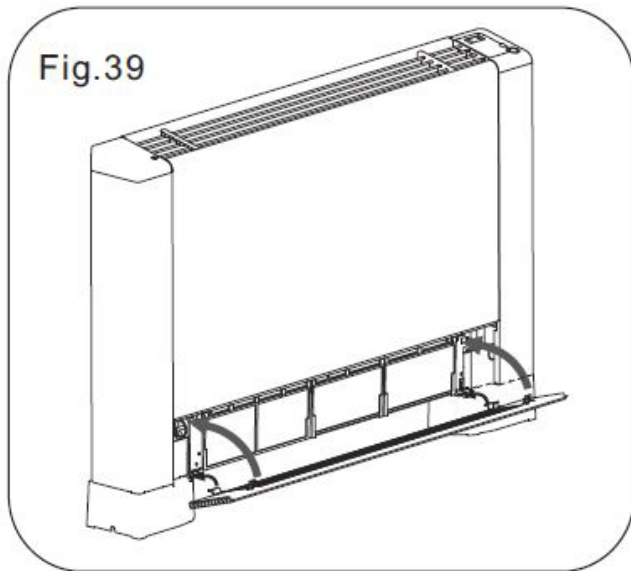

Warning: Cut off power supply before cleaning or maintaining the unit.

3. Front Panel Operation

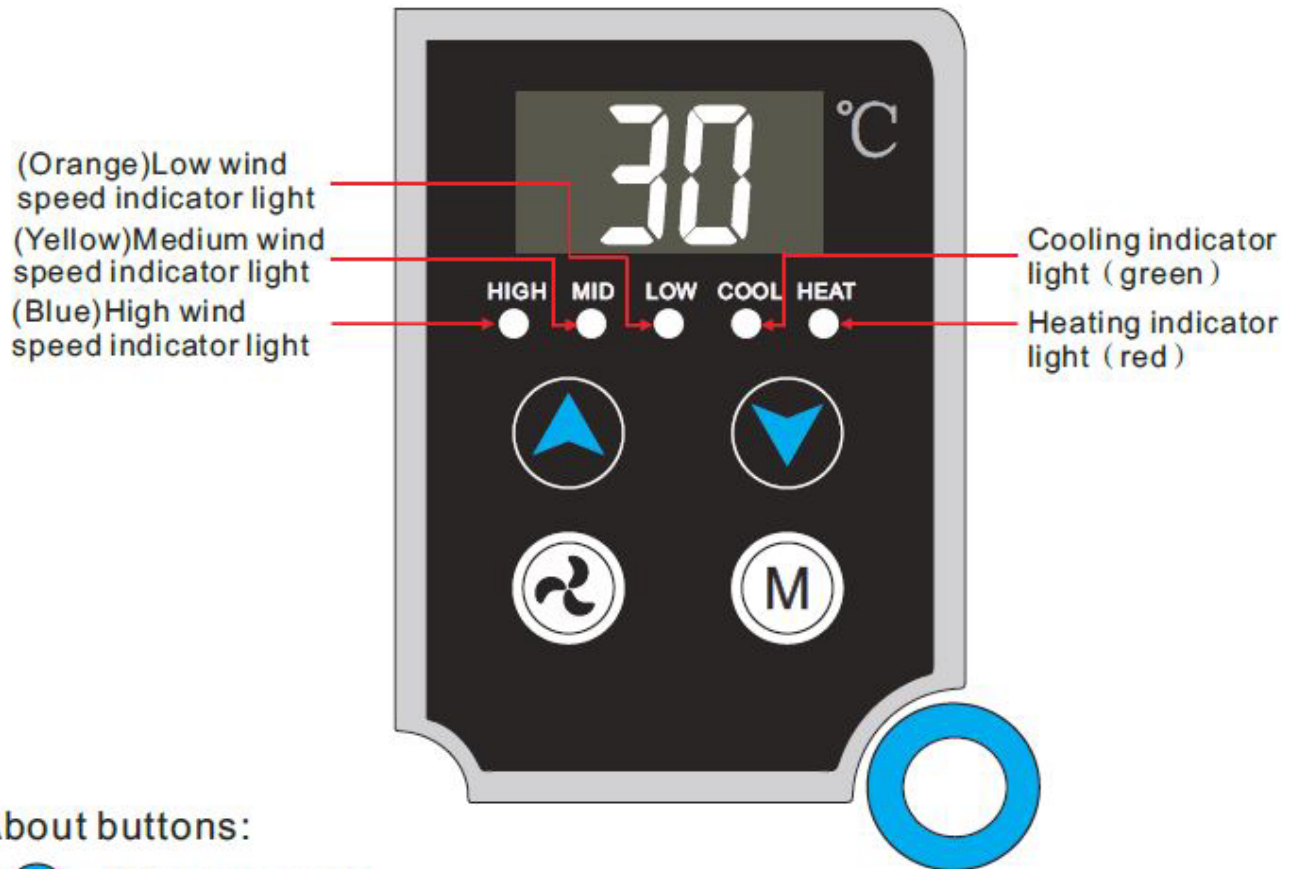

About buttons:



ON/OFF BUTTON

Pressing this button would start up or shut down the unit



Press this button and select the mode you want to set.

Cooling mode: Cooling indicator light keeps on (green)

Heating mode: Heating indicator light keeps on (red)

Automatic mode: Cooling indicator light and heating indicator light flashes in turn.

Ventilating mode: Cooling and heating indicator lights are off, the fan indicator light keeps on according to the chosen fan speed.

Dehumidifying mode: Cooling indicator light keeps on for 2 seconds and off for 1 second.

Note: Changes of mode could only be done on main interface.



Press this button and select the fan speed you want to set.

High fan speed: High fan speed indicator light keeps on (blue)

Medium fan speed: Medium fan speed indicator light keeps on (yellow)

Low fan speed: Low fan speed indicator light keeps on (orange)

Automatic: High fan speed indicator light, medium fan speed indicator light and low fan speed indicator light flashes in turn.

Note: Changing the fan speed can only be done on main interface. You cannot choose the automatic fan speed when in ventilating mode. When in dehumidifying mode, the fan speed is fixed in low speed. Changes of fan speed can only be done on the main interface.

- ▲ You could check the set temperature of unit by pressing this button once. You could increase the setting temperature by pressing this button again.
- ▼ You could check the set temperature of unit by pressing this button once. You could decrease the setting temperature by pressing this button again.

Temperature Setting

When you are on the main interface of the heating or cooling mode you can press

“▲” or “▼”

Once to check the setpoint temperature. Press “▲” or “▼” again to increase or decrease the set point temperature. Press “M” or “↻” or POWER ON/OFF button to change the mode, fan speed or shutdown the unit and save the settings. The system will save the current settings and return to the main interface if any of the buttons aren’t touched after 5 minutes.

“▲” or “▼” is invalid when the unit is in the ventilation mode, automatic mode or dehumidifying mode.

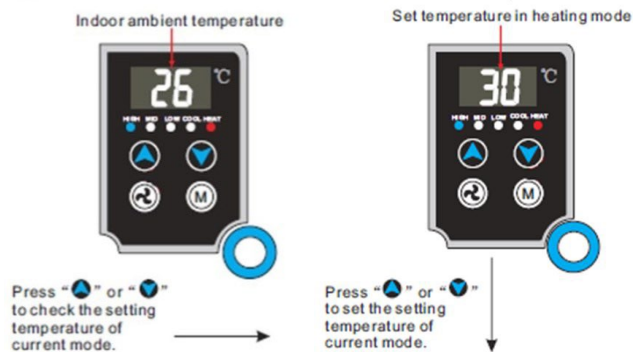

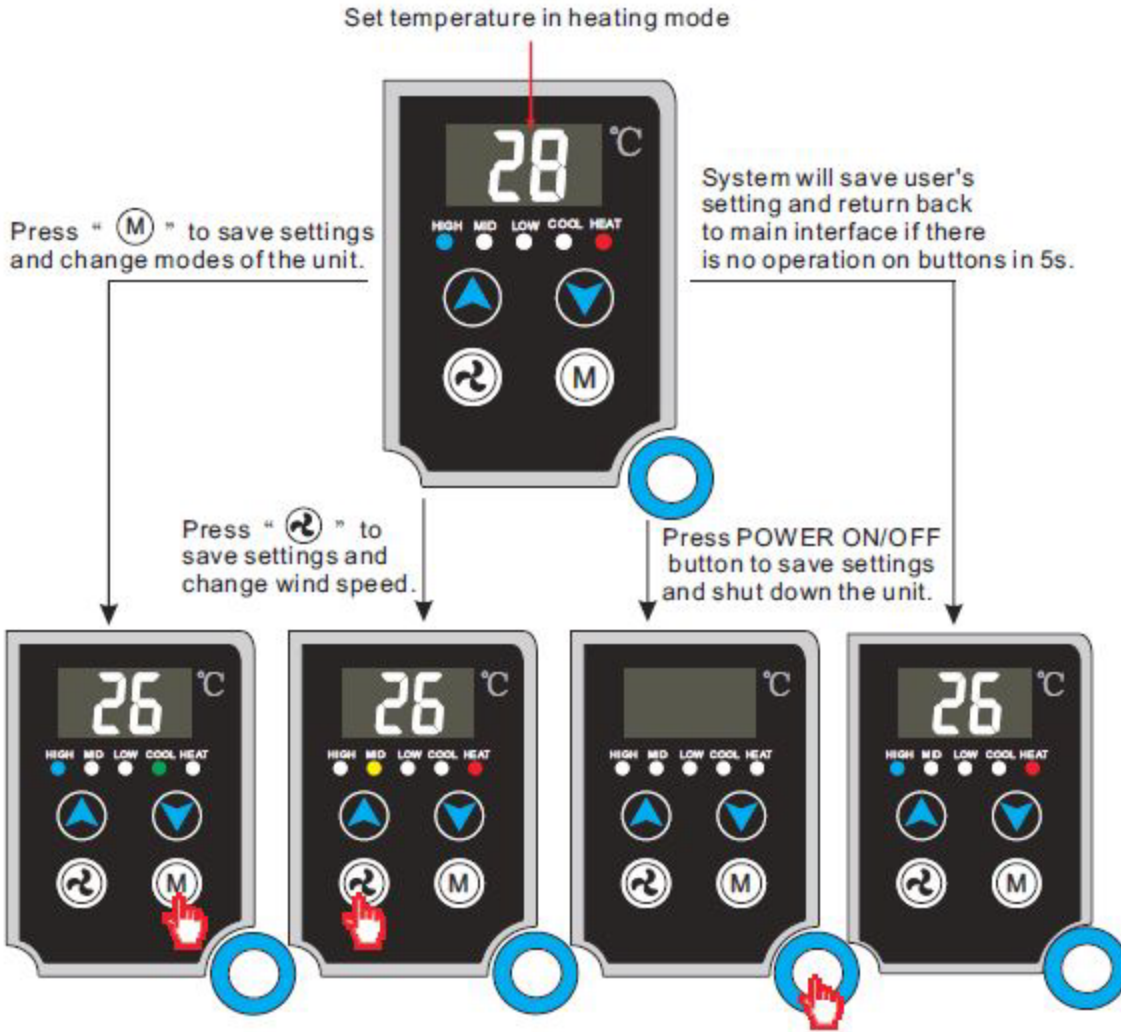

4. Parameter Settings

Parameter Setting

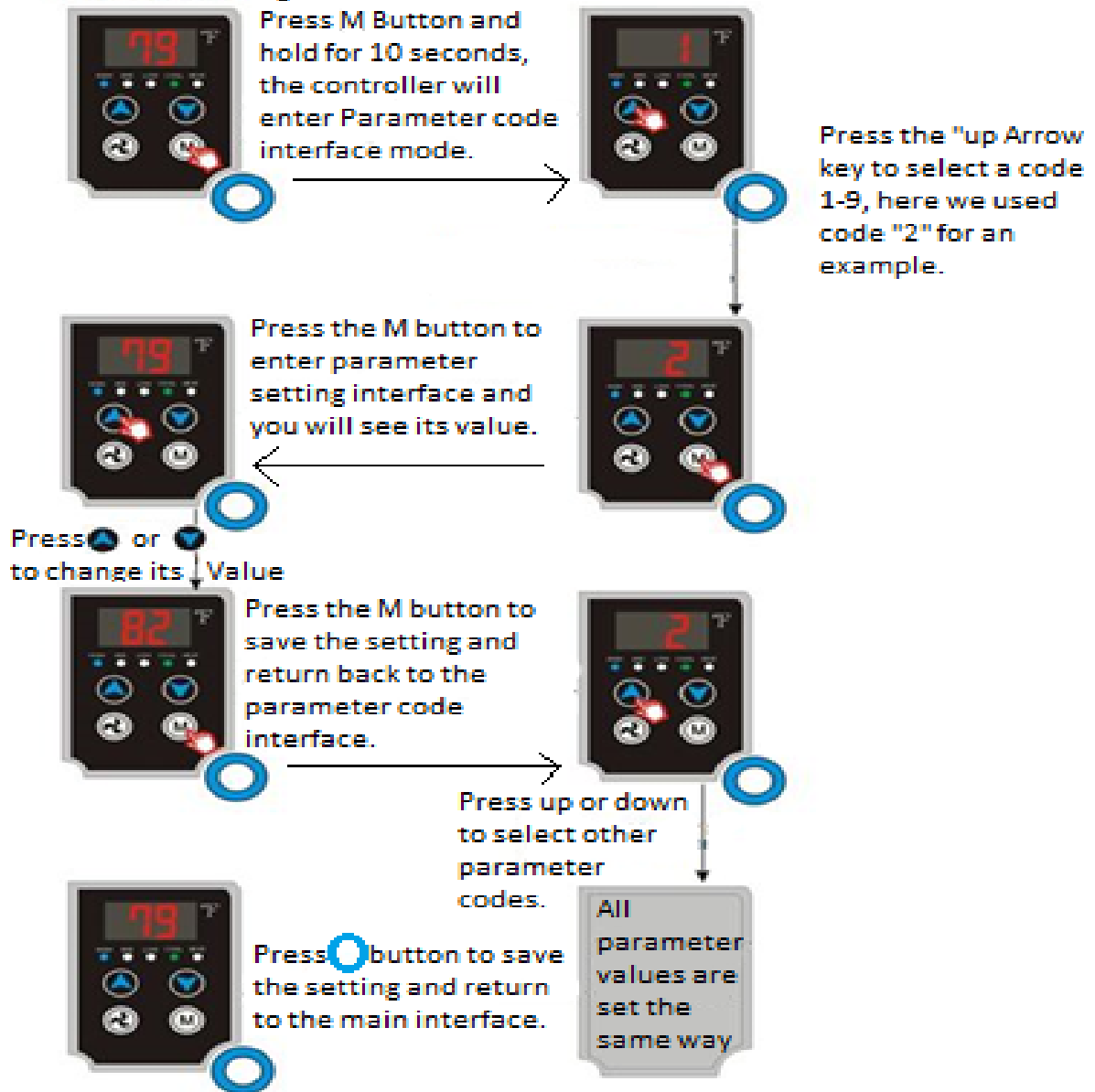

Notes:

- 1) The operation of all parameter settings is the same.
- 2) If you press the on/off button when the controller is showing the parameter value, it will switch back to the main interface without saving the setting.

3) If there is no operation in 20 seconds, system would remember the setting and switch back to main interface. To enter the parameter mode press and hold the mode button down for 10 seconds.

If your serial number begins with “242” you will see a “0” on the panel, this indicated that you have a ZLPF10 controller. All other serial numbers should show a “01”, This indicates that you have an MD1001 controller. If you have a 0 on the panel then use the up-arrow key until you see “66”. Hit the mode button and you will see “01”. This is parameter number 1, then touch the mode button to display the parameter value. Use the up/down arrows to set the parameter value and then touch the mode button to lock it in. This will bring you back to the parameter number, use the up-arrow key to move to parameter #2, hit the mode button to view/change the value. Repeat this sequence for all 20 parameters, to save them press the power off button when parameter 20 is shown on the display.

Fan coil parameter list for ZLPF10 Controllers

ZLPF10 Controllers Only			
No.	Meaning	Range	Default
01	Maximum Target temp upper limit, (cooling, heating, auto mode)	60°F ~ 99°F	86°F
02	Minimum Target temp upper limit, (cooling, heating, auto mode)	60°F ~ 99°F	46°F
03	Target temp in cooling mode. If the room temp is ≥ 79°F, the fan will come on. If the room temp is ≤ 78°F, the fan will turn off.		78°F
04	Target temp in heating mode. If the room temp is ≤ 67°F, the fan will come on. If the room temp is ≥ 68°F, the fan will turn off.		68°F
05	Automatic mode target cooling temp. If the room temp is ≥ 79°F the fan will come on in cooling mode. If the room temp is ≤ 78°F and parameter 20=1, the fan coil will run for 1 min. every 15 min.		78°F
06	Automatic mode target heating temp. If the room temp is ≤67°F the fan will come on in Heating mode. If the room temp is 68°F and parameter 20=1, the fan coil will run for 1 min. every 15 min.		68°F
07	In heating mode, if the coil temp is lower than Parameter 07, the fan motor will stop.	41°F ~ 104°F	77°F
08	In cooling mode, if the coil temp. is higher than 68°F, the fan motor will stop. (1-Yes; 0-No)	0 ~ 1	1
09	Start the ultra-low fan speed (1-Yes; 0-No)	0 ~ 1	1

10	Is there a water valve (1-Yes; 0-No)	0 ~ 1	0
11	Is there floor heating (1-Yes; 0-No)	0 ~ 1	0
12	Display in Fahrenheit (1-°F; 0-°C)	0 ~ 1	1
13	Is it the main controller (1-Yes; 0-No)	0 ~ 1	1
14	Local address	0 ~ 99	15
15	Lock the Keypad (1-Yes; 0-No)	0 ~ 1	0
16	When the keypad is locked, is the remote controller working? (1-Yes; 0-No)	0 ~ 1	1
17	Is there a password that should be input before locking the keypad? (1-Yes; 0-No)	0 ~ 1	0
18	Password 1	50	50
19	Fan settings in cooling mode (see descriptions below)	0-2	0
20	Fan settings in cooling mode (see descriptions below)	0-2	0

Parameters 19 & 20 Descriptions

Parameter#19

In cooling mode, when the target temperature is reached, it has three options for setting regarding how the fan works.

1) Parameter#19

In cooling mode, when the target temperature is reached, it has three options for setting regarding how the fan works.

1) 0 - The fan shut off.

2) 1 - The fan operates intermittently; it turns on 1 minute for every 15 minutes operating.

3) 2 - The fan works continuously

Remark: When parameter#10 is 0, parameter#19 can't be set to 2.

Parameter#20

In heating mode, when the target temperature is reached, it has three options for setting regarding how the fan works.

1) 0 - The fan shut off

2) 1 - The fan operates intermittently; it turns on 1 minute for every 15 minutes operating

3) 2 - The fan works continuously

Remark: When parameter#10 is 0 parameter#19 can't be set to 2.

Fan coil parameter list for MD1001 controllers

MD1001 Controllers Only			
No.	Meaning	Range	Default
01	Maximum Target temp upper limit, (cooling, heating, auto mode)	60°F ~ 99°F	86°F
02	Minimum Target temp upper limit, (cooling, heating, auto mode)	60°F ~ 99°F	46°F
03	Target temp in cooling mode. If the room temp is $\geq 79^{\circ}\text{F}$, the fan will come on. If the room temp is $\leq 78^{\circ}\text{F}$, the fan will turn off.		78°F
04	Target temp in heating mode. If the room temp is $\leq 67^{\circ}\text{F}$, the fan will come on. If the room temp is $\geq 68^{\circ}\text{F}$, the fan will turn off.		68°F
05	Automatic mode target cooling temp. If the room temp is $\geq 79^{\circ}\text{F}$ the fan will come on in cooling mode. If the room temp is $\leq 78^{\circ}\text{F}$ and parameter 20=1, the fan coil will run for 1 min. every 15 min.		78°F
06	Automatic mode target heating temp. If the room temp is $\leq 67^{\circ}\text{F}$ the fan will come on in Heating mode. If the room temp is 68°F and parameter 20=1, the fan coil will run for 1 min. every 15 min.		68°F
07	In heating mode, if the coil temp is lower than Parameter 07, the fan motor will stop.	41°F ~ 104°F	77°F
08	In cooling mode, if the coil temp. is higher than 68°F, the fan motor will stop. (1-Yes; 0-No)	0 ~ 1	1
09	Start the ultra-low fan speed (1-Yes; 0-No)	0 ~ 1	1
10	Is there a water valve (1-Yes; 0-No)	0 ~ 1	0
11	Is there floor heating (1-Yes; 0-No)	0 ~ 1	0
12	Display in Fahrenheit (1-°F; 0-°C)	0 ~ 1	1
13	Is it the main controller (1-Yes; 0-No)	0 ~ 1	1
14	Local address	0 ~ 99	15
15	Lock the Keypad (1-Yes; 0-No)	0 ~ 1	0
16	When the keypad is locked, is the remote controller working?	0 ~ 1	1

	(1-Yes; 0-No)		
17	Is there a password that should be input before locking the keypad? (1-Yes; 0-No)	0 ~ 1	0
18	Password 1	50	50
19	Password 2	50	50
20	In Auto mode, the fan motor will intermittently turn on and off. (1-Yes; 0-No)	0	0

5. REMOTE CONTROL

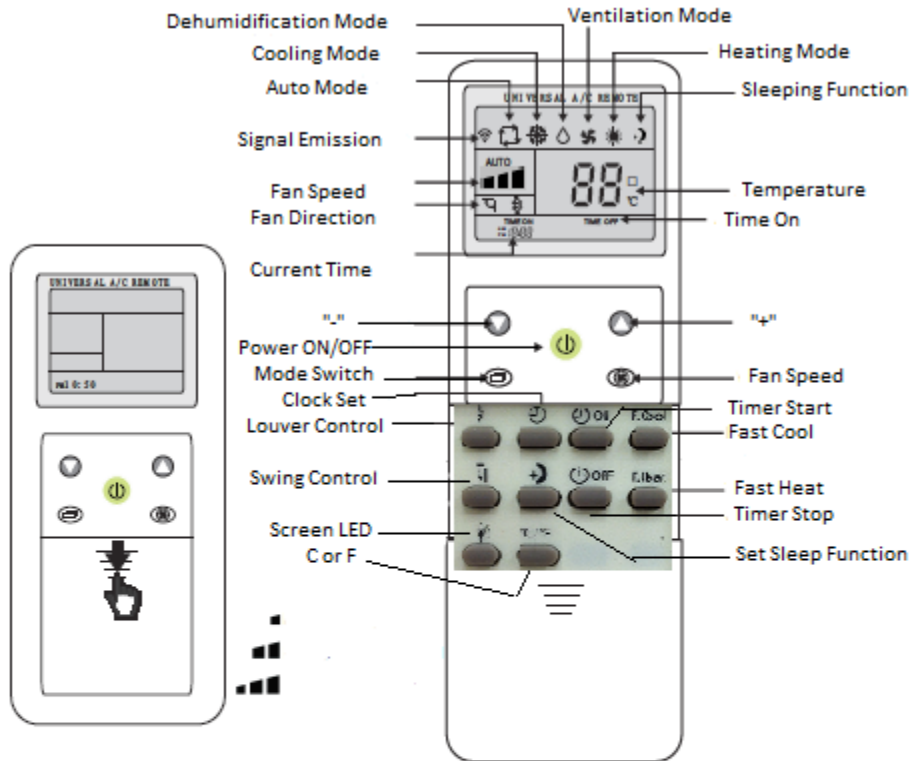

 POWER ON/OFF

 **MODE** Mode Switch
Press this key to switch the mode between Auto, Cooling, Dehumidifying, Ventilation and Heating.

 **FAN** Fan Speed
Press this key to select the fan speed between Auto, High, Medium, and Low.

 "+"
Press this key to increase the value.

 "-"
Press this key to decrease the value.

Note:

- 1) The key "SET" and "OK" are disabled.
- 2) Take out the batteries if you do not use the remote controller for a long time.
- 3) Take out the batteries for 35 minutes to reset the remote controller.

Using the remote controller

5.4.1 Function of “F.Cool” and “F.Heat”

By pressing the key “F.Cool”, the system will be automatically set to the cooling mode With a high fan speed.

By pressing the key “F.Heat”, the system will be automatically set to the heating mode with a high fan speed.

5.4.2 Time Setting

Press and hold the key “⌚” till the time value flashes, then you can adjust the current time value by pressing the key “+” or “-”. To save the setting above, please press the key “⌚” again. Attention, the 12-hour clock is adopted to show the current time value.

5.4.3 Timing Start-Up or Timing Shut-Down

“⌚” ON This key is available only when the unit is POWER OFF, but not interruption of power supply.

TIME ON / 1 One hour after setting Timing Start-Up, the unit will automatically start up. The number shown stands for the timing hours.

“⌚” OFF This key is available when the unit is POWERED ON.

TIME OFF / 1 One hour after setting Timing Shut-Down, the unit will automatically shut down. Also, the number shown stands for the timing hours.

The range of timing is from 1 hour to 11 hours. If the setting value is over 11 hours, the setting of timing will be cancelled.

5.4.4 Sleeping Function

① To start or cancel the sleeping function, please press the key “☾” .

② The sleeping function can only be set in the heating or cooling mode.

③ When the sleeping function is activated, the icon “☾” will be shown at the top right corner of the LCD screen which belongs to the remote controller. Meanwhile, “TIME OFF” and “7” will be shown at the lower right corner of the LCD screen. It means that the unit will automatically shut down 7 hours after the setting . To change the timing number, even to cancel the timing function , please press the key “⌚OFF”.

④ 1 hour after setting the sleeping function, the wind speed will automatically change to the low wind speed, but then you can also change the wind speed by press “⊙” .

⑤ In two hours after setting the sleeping function in the cooling mode, the set temperature will increase 1 °C or about 2°F per hour.

⑥ In three hours after setting the sleeping function in the heating mode, the set temperature will decrease 1 °C or about 2°F per hour .

5.4.5 Switch to Celsius or Fahrenheit

To Switch to Celsius or Fahrenheit, please press the key “C°/F° ” .

5.4.6 LED Screen Light Up or Not

To let the LED Screen of the unit light up or not, please press the key “💡” .

6. Wiring Diagram MD1001

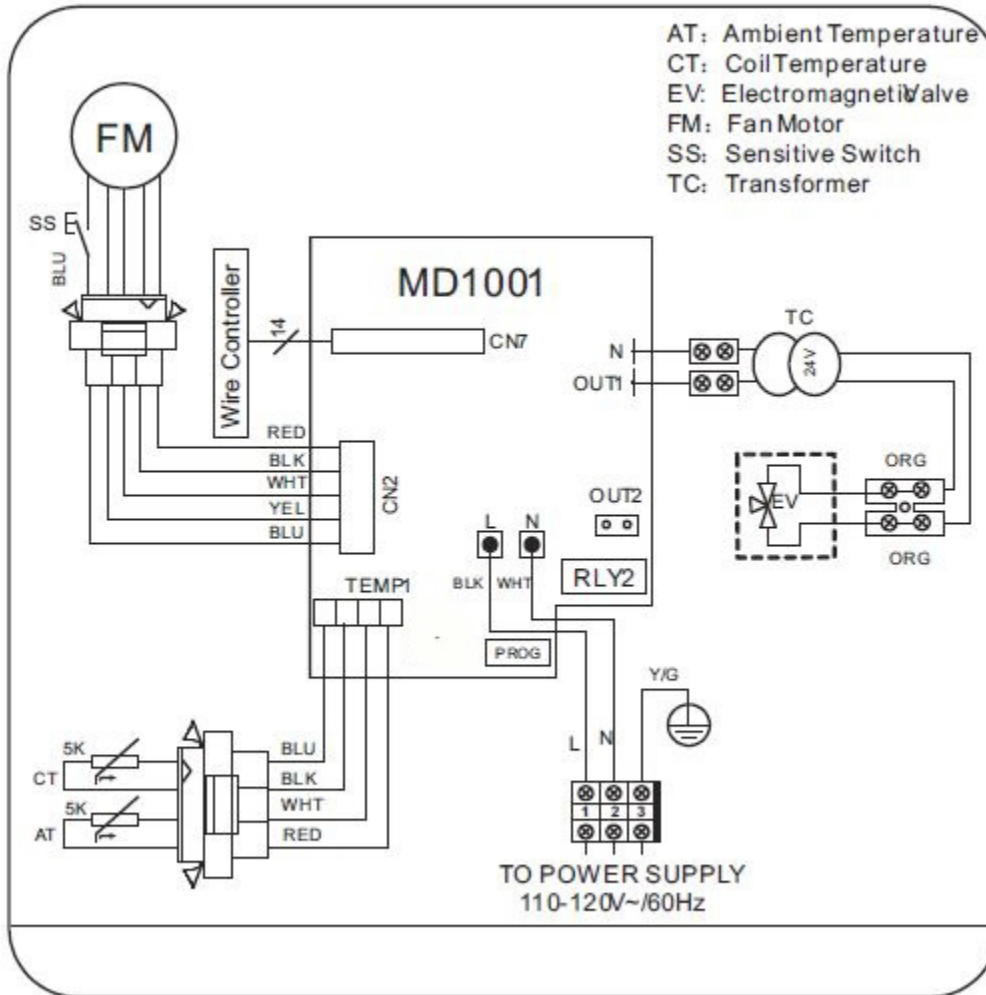

NO.	Signal	meaning
1	CN2	DC Fan Motor
2	OUT2	Output without connecting to power
3	CN1	To wire controller (LED)
4	PROG1	Program Burn
5	TEMP1	To ambient and coil temperature
6	OUT1	To electromagnetic valve
7	L	Live wire
8	N	Neutral wire

7. Wiring Diagram ZLFP10

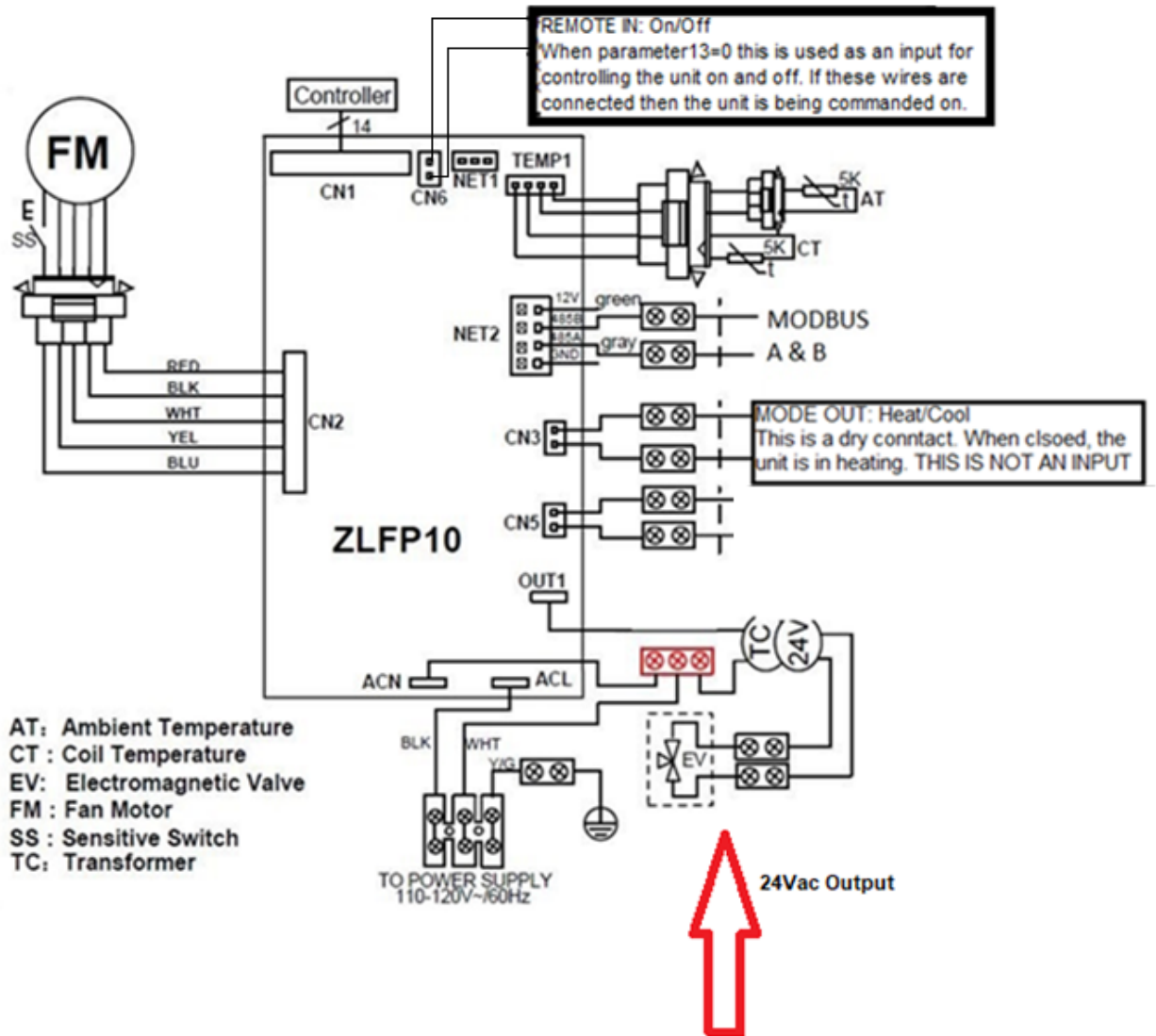

8. Wiring Diagram ZLFP10-S

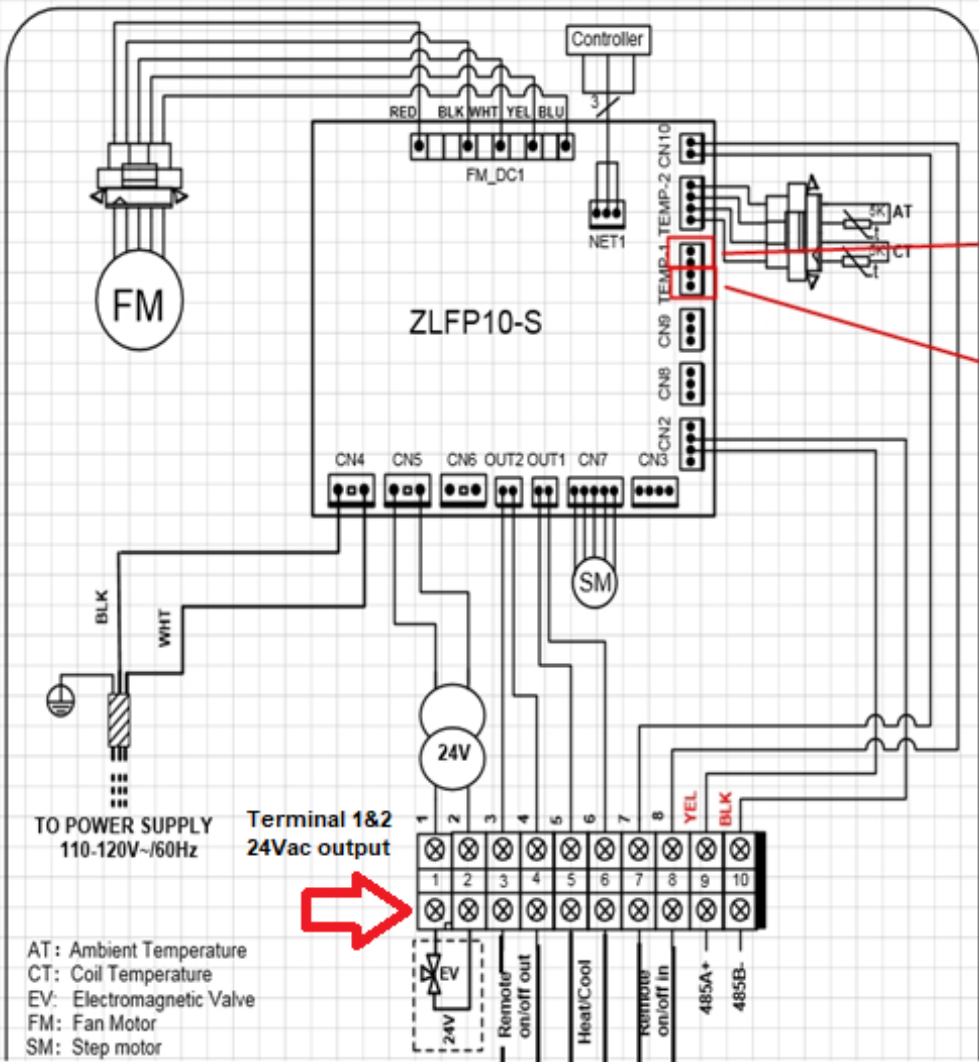

AT: Ambient Temperature
 CT: Coil Temperature
 EV: Electromagnetic Valve
 FM: Fan Motor
 SM: Step motor

REMOTE OUT: On/Off
 This is a dry contact and is used when the fan coil is master control on the system. When the fan coil is on then this will be a closed circuit. **THIS IS NOT AN INPUT**

REMOTE IN: On/Off
 When Parameter 13 =0 this is used as an input for controlling the unit on and off. If these wires are connected then the unit is being commanded on.

MODE OUT: Heat/Cool
 This is a dry contact. When closed, the unit is in heating, when open it is in cooling. **THIS IS NOT AN INPUT**

AN3
 REMOTE IN HEATING: Use the chart below to understand the logic for this input. (THIS IS A DRY CONTACT, NO VOLTAGE APPLIED)

AN4
 REMOTE IN COOLING: Use the chart below to understand the logic for this input. (THIS IS A DRY CONTACT, NO VOLTAGE APPLIED)

	AN4 CONNECTED	AN4 DISCONNECTED
AN3 CONNECTED	Unit is being commanded OFF	Unit is being commanded on in heating mode
AN3 DISCONNECTED	Unit is being commanded on in cooling mode	Nothing: the unit is run from the OEM controller.

9. Standard Fan Coil Loop Pump Wiring

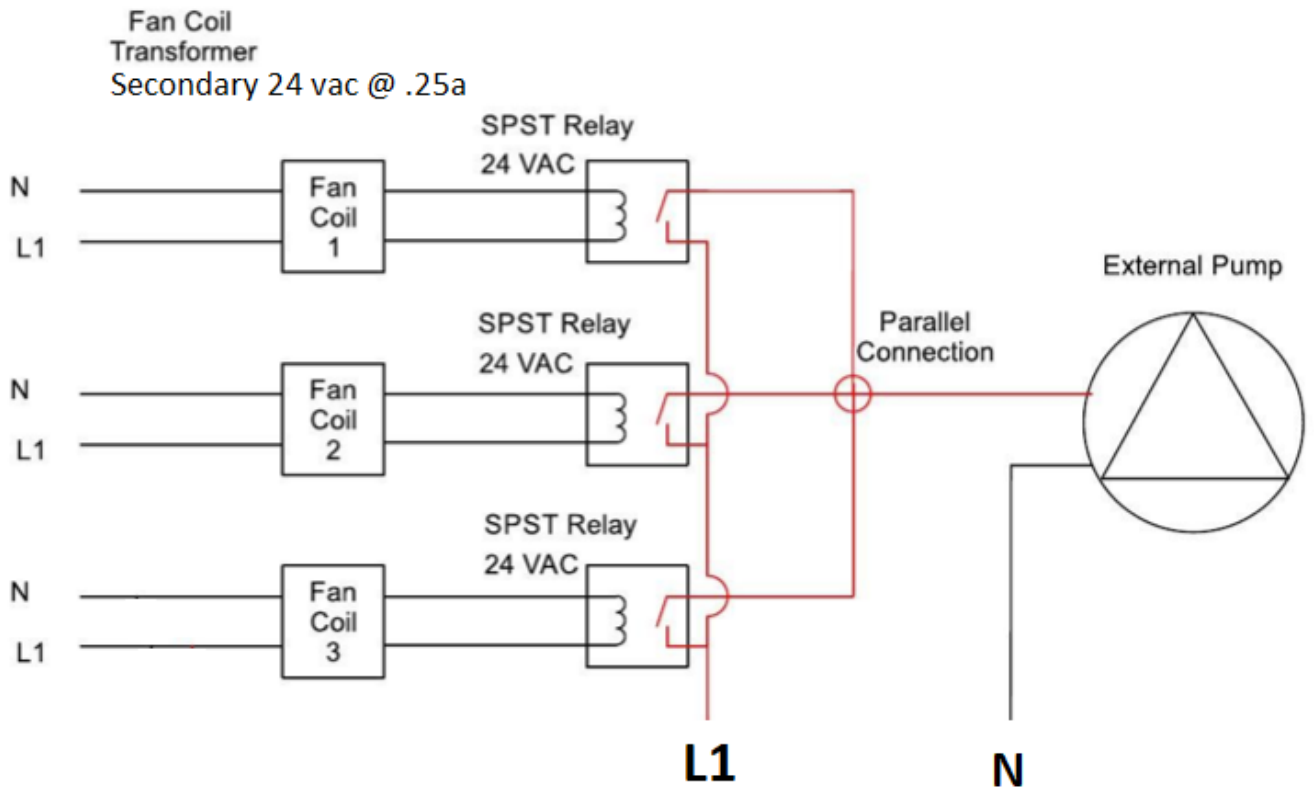

Typical control circuit for adding a second pump to a fan coil Loop using SPST 24vac coil relays.

Relay coil rated @ .25 amps Max.

Relays must have the proper contact load rating for the selected pump. 120 vac pump shown.

Parameter #10 must be set to a 1 to activate the relay on a call for heating or cooling.

9.5 External Control

The CXI units have the option to be remotely turned off and on via a dry connection, IE: not voltage applied. Below are picture of Remote IN.

In order to enable this, the parameter P13 must be changed to 0. The moment you change P13 to 0 the unit will turn off. To turn the unit back on, you will need to connect "Remote In" together. This will enable the unit to turn back on. This should be done via the control schematic as show below using a 3rd party controller. Shown below is the "Remote IN" disconnected while the relay is NOT energized.

The fan coil unit will turn on and off based on the connection status of "Remote In", the unit will remember its last setting for mode and target temp and continue to run based on the conditions.

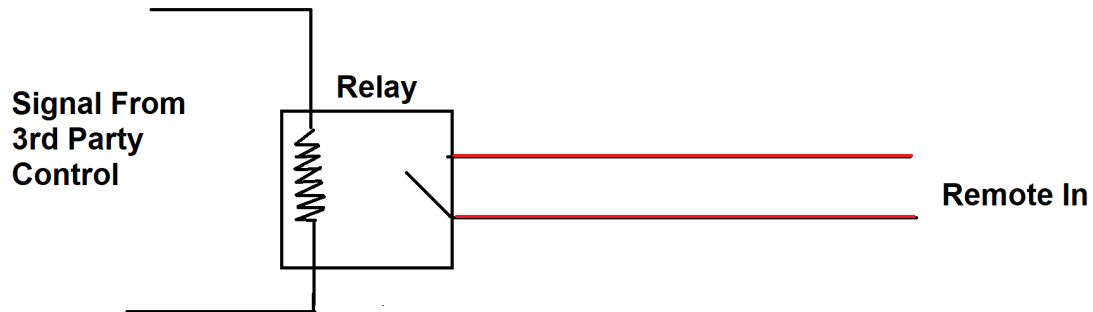

Note: The unit also has more advanced features that can be utilized to control another 3rd party unit or can accept Modbus controls. if you feel this is necessary for your application then please contact Chiltrix support department. 757-410-8640

1. Troubleshooting

Malfunction	Code	Cause	Measures
Indoor ambient temp sensor	P4	Ambient temperature sensor is open or shorted	Check or replace the ambient temperature sensor
Coil temp sensor	P5	Coil temperature sensor is in open circuit or short circuit	Check or replace the Coil temperature sensor
Motor feedback signal	E0	Air intake grill open or grill not closed tight Possible Fan motor failure	Close the air intake grill Replace the motor
Flashing Heat or Cool Leds		Low water temp or high water temp	Check loop temp by pressing up/down arrow keys at the same time to display water temp
2.0 or 1.8 boot revision displayed	2.0 or 1.8	Controller has problem reading parameters	Disconnect 120 vac for one minute. Set all parameters to default values

2. Resistance Chart

Temperature Degrees (C)	Temperature Degrees (F)	Resistance in Kilo-Ohms	Temperature Degrees (C)	Temperature Degrees (F)	Resistance in Kilo-Ohms
-40	-40	166.8 kΩ	30	86	4 kΩ
-35	-31	120.5 kΩ	35	95	3.2 kΩ
-30	-22	88 kΩ	40	104	2.6 kΩ
-25	-13	65 kΩ	45	113	2.2 kΩ
-20	-4	48.4 kΩ	50	122	1.8 kΩ
-15	5	36.4 kΩ	55	131	1.5 kΩ
-10	14	27.6 kΩ	60	140	1.2 kΩ
-5	23	21 kΩ			
0	32	16.3 kΩ			
5	41	12.7 kΩ			
10	50	10 kΩ			
15	59	7.8 kΩ			
20	68	6.2 kΩ			
25	77	5 kΩ			

3. Exploded Views

Chiltrix CXI series

