

DC INVERTER

AIR TO WATER HEAT PUMP CX34-3

For Use with units shipped after 10-12-2018 with serial number equal to or lower than CX3421030049 (If unsure, contact Chiltrix technical support dept.)

Installation and Operation Manual CX34-3 Options for Heating, Cooling and Domestic Hot Water

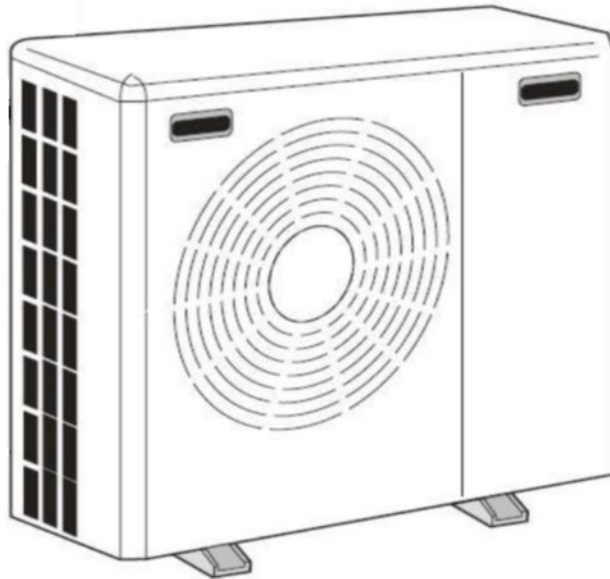

PLEASE REVIEW ENTIRE MANUAL BEFORE PROCEEDING

**PLEASE SUBMIT SYSTEM DRAWING & SCHEDULE A COMMISSIONING
CALL BEFORE STARTING THE UNIT**

Version 2.1



Table of Contents

Safety Precautions.....	Page 3
CX34 Components.....	Page 4
Hydronic Piping and Design.....	Page 5
Buffer Tanks.....	Page 7
Head/Pressure Drop Calculations.....	Page 8
Using Glycol.....	Page 11
Heat Pump Installation.....	Page 12
Valves G1, G2, G3.....	Page 20
Second Heat Source.....	Page 25
External T-Stat Control.....	Page 26
System Filling/Purging.....	Page 28
Using The Controller/Operation.....	Page 30
P-Parameter Setting	Page 45
Status/C-Parameter Checking.....	Page 50
About Screen (Software Version)	Page 53
Initial Temperature Settings.....	Page 53
Error Codes.....	Page 54
Dynamic Outdoor Reset Control	Page 57
Commissioning and Initial Test Run.....	Page 59
Footprint/Placement Dimensions -----	Page 60

IMPORTANT NOTE – MAKE SURE TO PROVIDE YOUR DESIGN DRAWING FOR APPROVAL BEFORE GETTING STARTED, INCLUDING DESIRED OPERATING TEMPERATURES.

Safety Precautions

NOTE: It is required to read the Safety precautions in detail before operation. The precautions listed below are very important for safety, please follow all safety precautions.

General

- Make sure that the ground wire in the building is securely connected to earth.
- Wiring tasks should be carried out by qualified electricians only, in addition, they should check the safety conditions of power utilization, for example, verify that the line capacity is adequate, and the power cable isn't damaged.
- Users must not install, repair or relocate the unit. Improper procedures might lead to accidents e.g. personal injury caused by fire, electrical shock or unit's falling off its base, and water leaking into the machine. Please contact a professional service department if problems arise.
- The unit shall not be installed at a spot with the potential hazard of leaking flammable gas. If gas is leaking near the machine, there might be the risk of explosion.
- Make sure that the foundation of the unit is stable. If the foundation is unstable, the outdoor unit may come loose from its base and cause injury.
- Make sure that the GFCI installed at the service panel is working properly to avoid shock or fires.
- Note a GFCI breaker is not required for equipment operation or warranty but is a good idea even when not required by code.
- If any abnormality occurs in the unit (such as a burning smell is noticed inside the unit), cut off the power supply immediately, and contact a professional service department.
- Please observe the follow items when cleaning the unit. Before cleaning, shut off the electric supply of the unit first to avoid injuries caused by the fan operation.
- Do not rinse the unit with water because the rinsed unit may cause electric shock.
- Make sure to shut off the electric supply before maintaining the unit.
- Please do not insert fingers or sticks into air outlet or air inlet.

Transporting and storage

The machine must be transported and stored vertically at all times

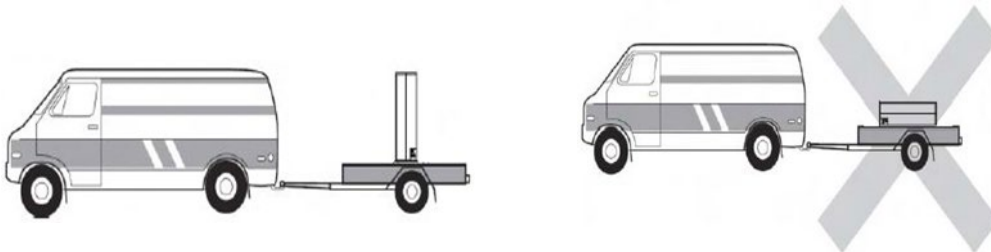

CX34 Components

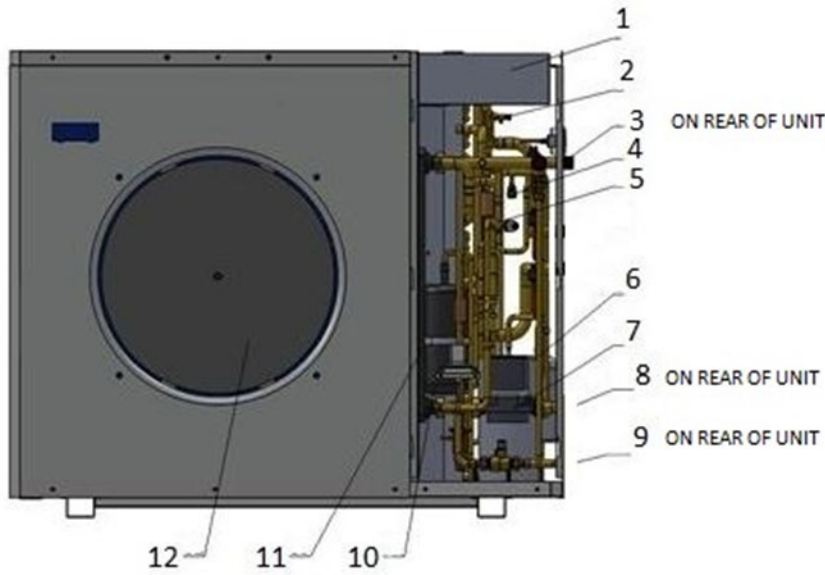

Position	Component	Position	Component
1	Electronics Box	7	Water Pump
2	Air Discharge Valve	8	Heat Pump Inlet
3	Heat Pump Outlet	9	Plate H.E. Drain
4	Needle Valve	10	Accumulator
5	4 Way Valve	11	Plate Heat exchanger
6	Compressor	12	Fan

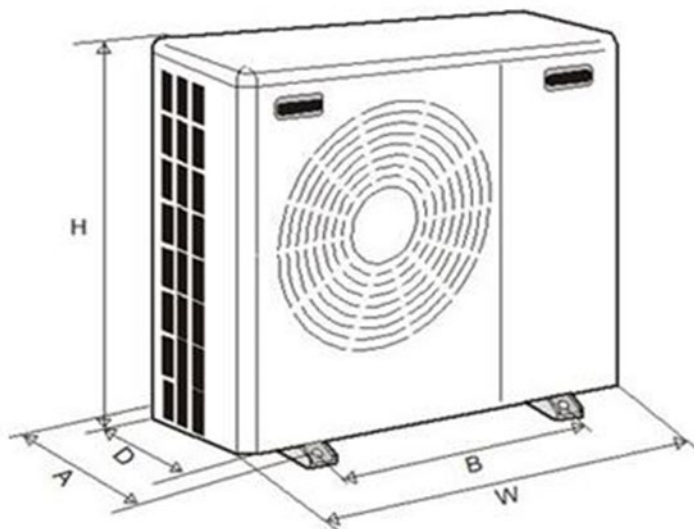

W	44"
D	16.75"
H	38"
A	17.5"
B	29.5"

Hydronic Piping and Design Guide

Installation Methods Heating and Cooling (Heating Shown)

See Design Guide Here
<https://www.chiltrix.com/documents/chiller-options.pdf>
**PLEASE ALWAYS SUBMIT YOUR DESIGN TO
 CHILTRIX FOR APPROVAL**

Note: Primary Secondary Piping or Closely Spaced Tees are NOT supported or recommended for use with this heat pump.

A buffer tank must be used for radiant heating. A multi-port buffer tank such as VCT37 should be used to combine multiple heat pumps.

An “additional volume” tank must be used when there is less than 15 gallons of total system fluid volume

Generic design, not all components shown

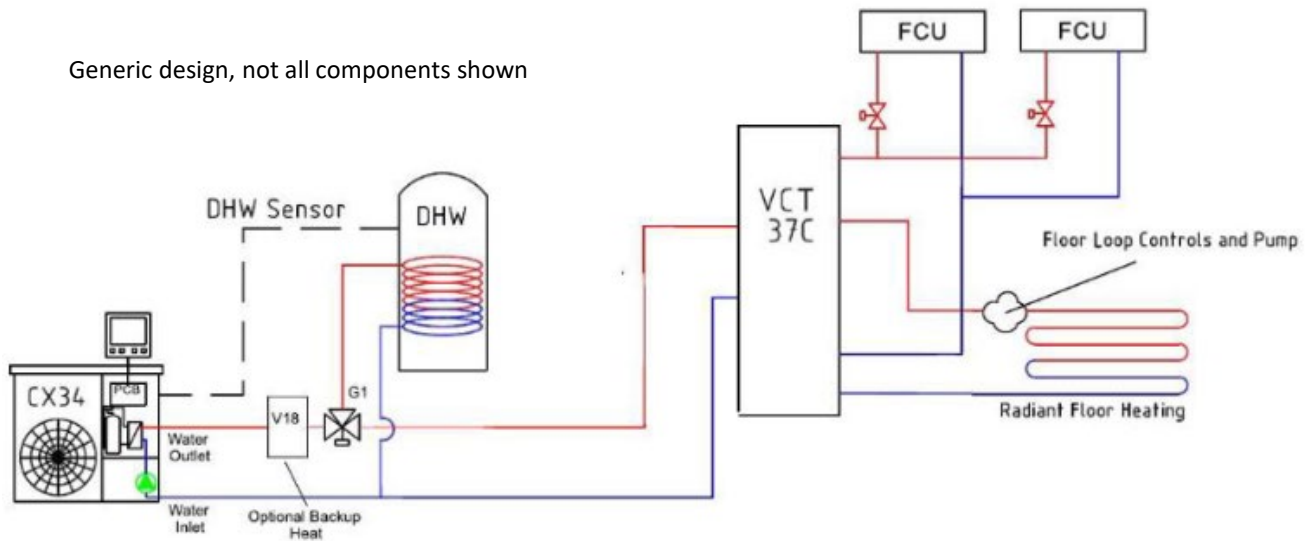

Minimum pipe size should be no less than 1”, CPVC or Oxygen Barrier PEX, reverse return piping is preferable to assist balancing. Reverse-return will not fully balance multiple chillers as the variable speed pumps may not always operate at the same speed. The installer should calculate the pipe and fitting resistance to determine the head pressure. See the examples on the following pages, maximum water flow for the CX34 is 6-7.5 gpm, design flow is 4.8 gpm. If necessary, a second Chiltrix-provided PWM pump may be added to the loop and controlled by the CX34. The second water pump connections are always in series with the internal pump. The loop example above is designed with wild coils (loads). Water flows through the fan coils at all times, if there is a call for heating or cooling the FCU controls will turn the fan on, adjust fan speed, etc. BTU leakage from a wild coil is around the same as a light bulb, not enough to worry about. Valved options are available and Chiltrix fan coil units can support valves, contact Chiltrix support to discuss.

An air discharge valve should be installed at the top of the circulation system, if possible, for easy air discharge. As an alternative an automatic/manual air vent can be used inline before the pumps.

Always install a mesh water filter or wye strainer on the return side pipe before it enters the heat pump to prevent blockage of the heat exchanger or pump/flow meter problems. A blocked heat exchanger can be a costly problem and is not covered by warranty so make sure to use a filter. Wye Filter Should be a \geq 60 mesh (\leq 250 Microns/0.25mm).

Piping Examples: Stacked Heat Pumps

Preferred Method For 2 or 3 Units:

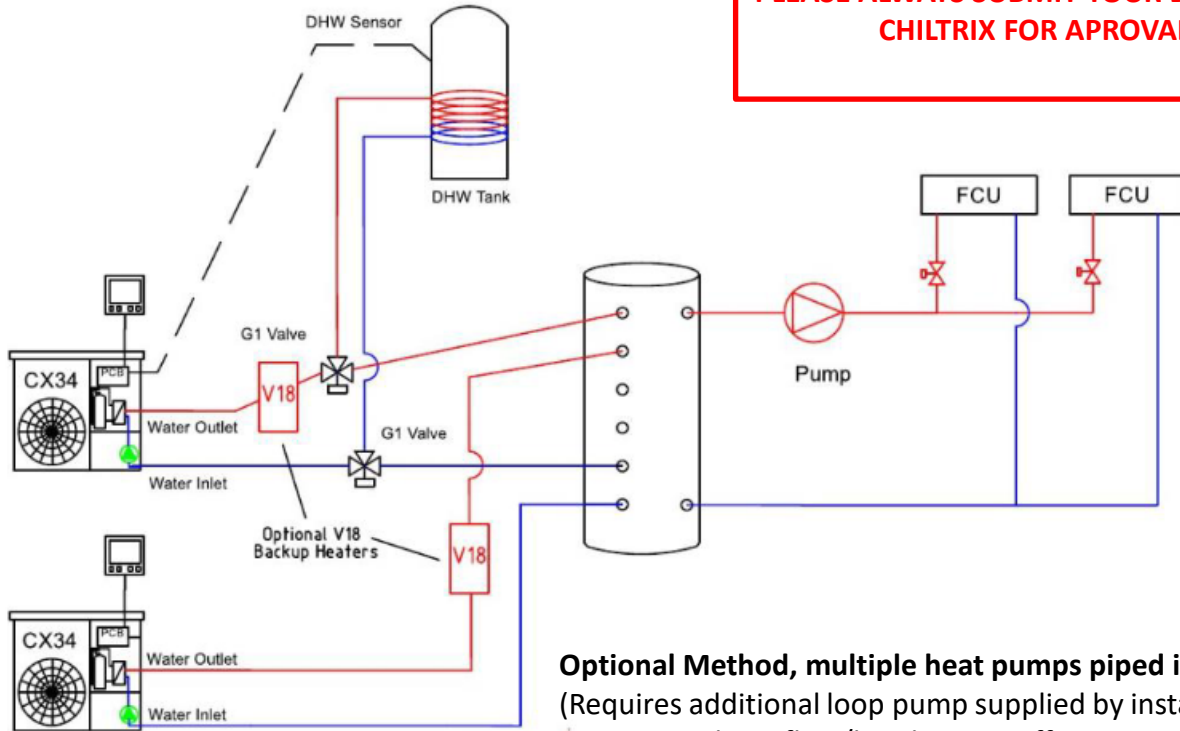

See Design Guide Here
<https://www.chiltrix.com/documents/chiller-options.pdf>

PLEASE ALWAYS SUBMIT YOUR DESIGN TO CHILTRIX FOR APPROVAL

Optional Method, multiple heat pumps piped in parallel:
 (Requires additional loop pump supplied by installer) This pump must have flow/head curve sufficient to overpower the total head/curve of both 2nd and any 3rd unit.

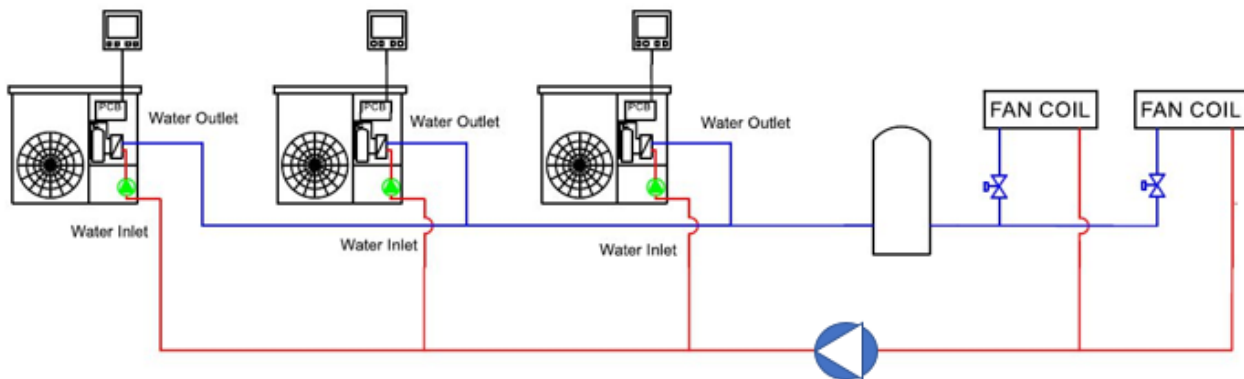

PLEASE SEND YOUR PROPOSED FINAL DESIGN TO CHILTRIX SUPPORT DEPARTMENT FOR APPROVAL, COMMENTS, AND SUGGESTIONS

Pipe Insulation

All loop piping must be insulated per local and national mechanical codes. Any piping in a system with chilled water (used for cooling) must also be sealed vapor tight to prevent condensate issues. For design tips and a thickness calculator please visit

<http://www.armacell.us/knowledge-center/>

Using a Buffer Tank w/ Radiant

Example below shows optional DHW, optional V18 backup heater, fan coils, and radiant. The radiant is attached to the load side of a buffer tank.

For V18 information please see the V18 Manual available on the Chiltrix website documents page.

For DHW or buffer tank installation information see the Chiltrix Tank Manual.

Be sure to check all ports on the tanks to ensure each oring/gasket is lubricated and tight to prevent leaking.

See Design Guide Here
<https://www.chiltrix.com/documents/chiller-options.pdf>

PLEASE ALWAYS SUBMIT YOUR DESIGN TO CHILTRIX FOR APPROVAL

If more than 2 fan coils are used, do not use this design below. See design guide doc.

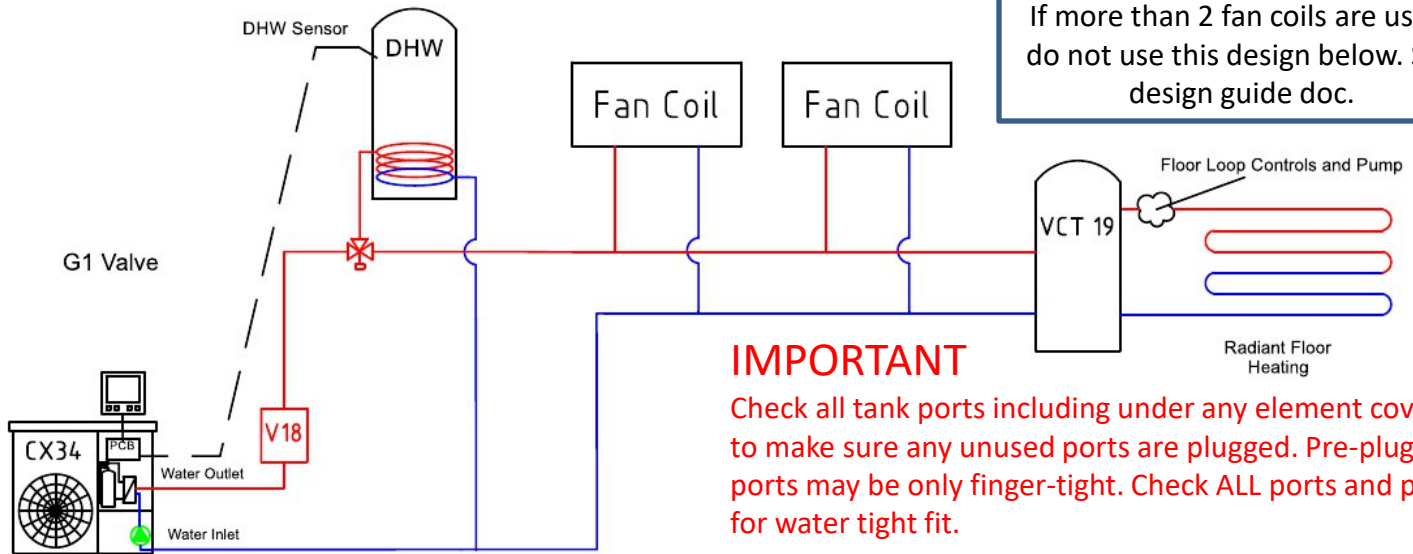

IMPORTANT
 Check all tank ports including under any element covers to make sure any unused ports are plugged. Pre-plugged ports may be only finger-tight. Check ALL ports and plugs for water tight fit.

Primary / secondary piping is not supported, when connecting to a floor heating loop always use a buffer tank. Buffer tanks are generally needed only with floor heating with the Chiltrix system, or to combine multiple CX34 units.

IMPORTANT NOTE ABOUT BACKUP HEAT
 Do not ever use buffer tanks for backup heat. The element capabilities of the buffer tank are provided for emergency heat only. Contact Chiltrix with any questions about emergency or backup heat options. See Chiltrix DHW & Tank Manual.

The radiant loop pump in the buffer tank drawing is controlled by the customer's floor loop controls, pump, etc. The buffer tank isolates the pumps from each other providing hydraulic separation and thermal buffering.

A 15-20 gallon buffer tank is used generally for best performance with a single CX34. 30-45 gallons is used for systems of two or three CX34s, and used when multiple CX34s are to be combined. A G3 seasonal valve may be used to isolate the tank in cooling mode, if applicable, note that isolating the buffer tank in this manner may cause the need for an additional volume tank to be added.

Head Calculation Example:

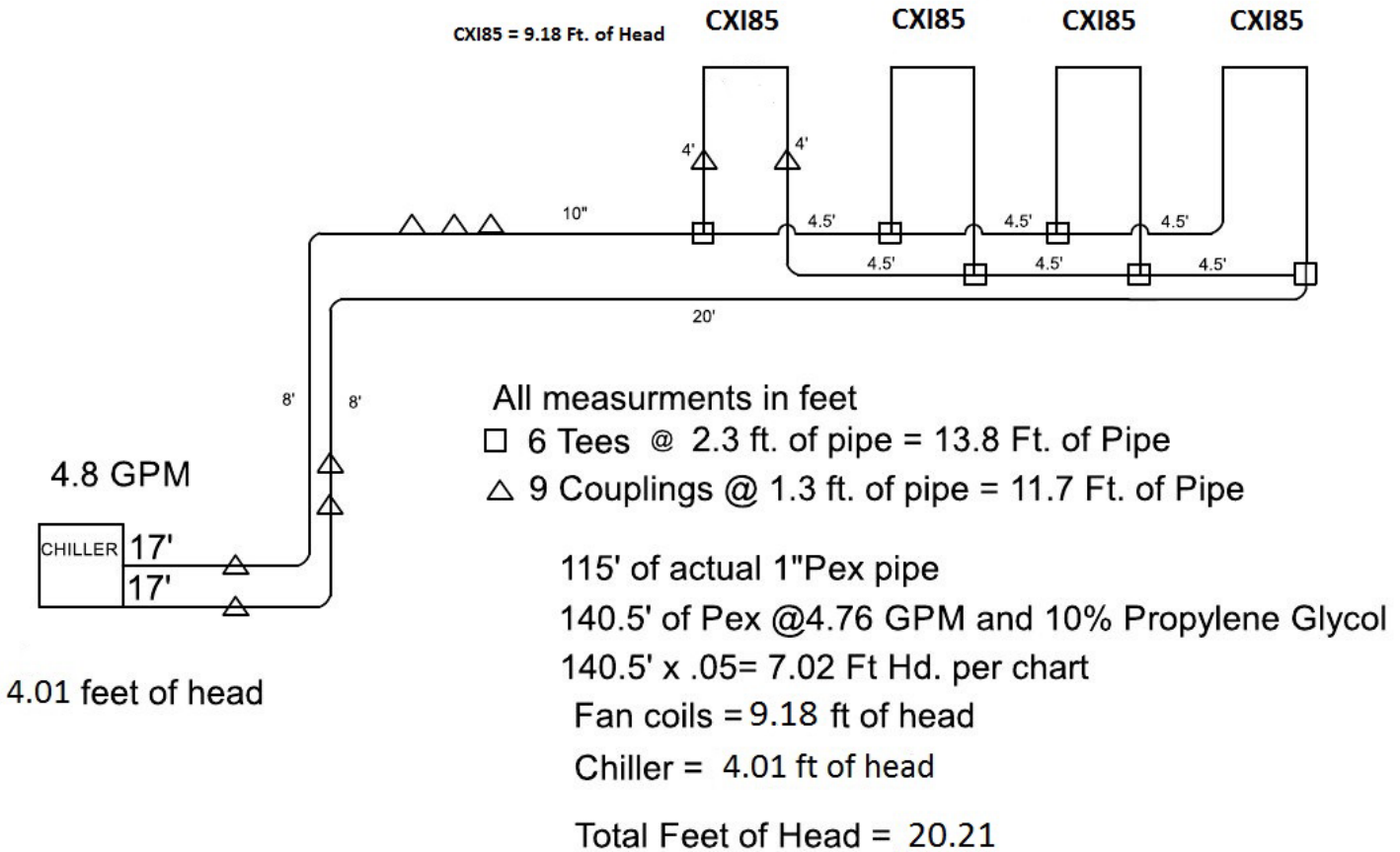

To calculate the head pressure for the correct water flow, the pipe length must be measured and all fittings counted. It is advisable to use flexible red oxygen barrier PEX piping and route it so as to avoid as many elbows as possible.

All fittings have an equivalent length of pipe already calculated, available on the next page under PEX Fittings Pressure Drops. Add up the equivalent length of pipe for the fittings, 13.8' + 11.7' = 25.5'. Then, add this to the actual pipe, 25.5' + 115' = 140.5' of 1" pipe. Once you know the total length of pipe, use a (1" PEX 10% Glycol, feet of head per 100 feet of tubing chart), to get the head for 1' of pipe, at 40°F and 4.76 GPM. This comes to (.0500) feet of head per foot. 140.5 x .0500 = 7.02 ft. of head.

Add up all head calculations, 7.02 + 9.18 + 4.01 = 20.21 ft. of head. Next, we will look at the Wilo Pump curve on page 13. Maximum head at 4.76 GPM is 23.67 ft.

If using the CX30SE (Free Cooling option) the CX30SE's pressure drop is 4.5 PSI when active.

Head Calculations - Continued:

The previously shown example loop has a volume of 4.5 gallons. The internal thermal expansion tank is 2 liters or .52 Gallons. The volume of the CX34 is 4.5 liters. An additional thermal expansion tank may be required for larger loops. There are many thermal expansion calculators on the internet, the following is an example.

<http://westank.com/calculator/>

Minimum loop pressure is 14.5 psi, maximum pressure is 43.5 psi, and ideal pressure is 29 psi. The lowest temperature is 44°F, the highest temperature is 131°F, the Initial pressure is 14.5 psi, and the final pressure is 29 psi.

A microbubble air separator should be installed in the loop preferably in the higher part of the loop to remove any air in the circulation loop. Always install a water filter or wye strainer on the supply pipe to the chiller to prevent blockage of the heat exchanger or damage to flow meter.

Nominal size	OD	Wall thickness	ID	Volume gal/100'
3/8"	0.500	0.070	0.350	0.50
1/2"	0.625	0.070	0.475	0.92
5/8"	0.750	0.083	0.574	1.34
3/4"	0.875	0.097	0.677	1.83
1"	1.125	0.125	0.863	3.03



WYE STRAINER (from supplyHouse.com)



Watts AS-MB
Microbubble Air Separator

PEX Brass Crimp Fittings Friction Loss - Equivalent Feet of PEX Tubing

Size	Coupling	Elbow	Tee Run	Tee Branch
3/8"	2.9	9.2	2.9	9.4
1/2"	2.0	9.4	2.2	10.4
3/4"	0.6	9.4	1.9	8.9
1"	1.3	10.0	2.3	11.0

GRUNDFOS UPM GEO25-85 230V PWM

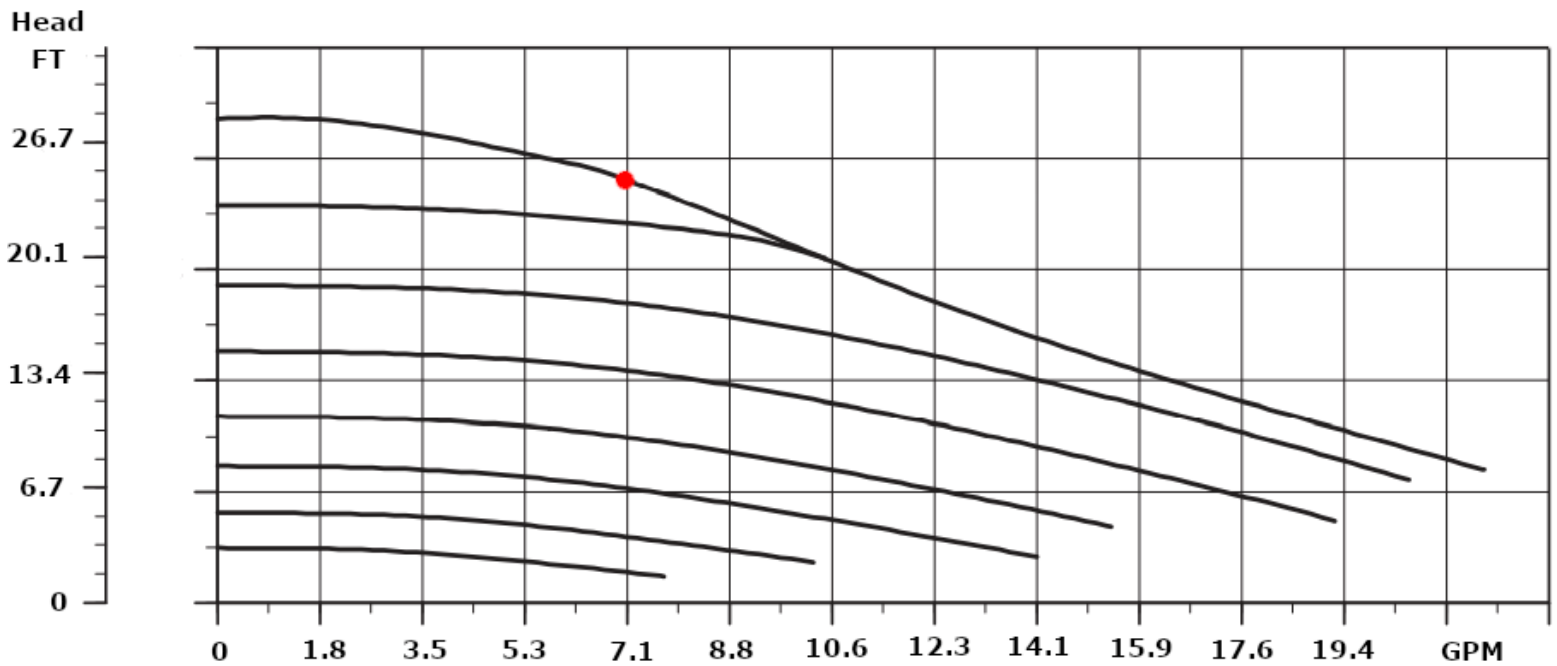

This is the Grundfos pump head curve for Chiltrix CX34 and is shipped with 2021 and newer CX34 units.

Note, the CX34 itself has 4.5 Ft. Head.

For head curve info on the previous Wilo pump, please see page 62,

Glycol

While not always required, customers in colder climates that are subject to occasional freezing should add an appropriate percentage of food-grade propylene glycol to the system. NEVER USE ETHYLENE GLYCOL. Ethylene Glycol is a poison. Propylene Glycol is a non-toxic anti-freeze also used in food, cosmetics, etc. and can safely be used.

Food-Grade Glycol is available at Home Depot and other retailers. You may also consider HSE Corn Glycol (Biodegradable Food-Grade Glycol made From Corn)
<https://www.hotspotenergy.com/corn-glycol/>

Below is a Freezing Point Chart For Propylene Glycol Mixed w/ Water

		Freezing Point						
Propylene Glycol Solution (%)	by mass	0	10	20	30	40	50	60
	by volume	0	10	19	29	40	50	60
Temperature	°F	32	26	18	7	-8	-29	-55
	°C	0	-3	-8	-14	-22	-34	-48

Flow Rates

Required flow rate changes with the glycol %.

Note the “500” formula water factors are adjusted as follows (based on 2,3 tons capacity):

00% glycol use $500 \frac{24,000}{500/10}=4.8$ GPM	00% glycol use $500 \frac{36,000}{500/10}=7.42$ GPM
10% glycol use $494 \frac{24,000}{494/10}=4.85$ GPM	10% glycol use $494 \frac{36,000}{494/10}=7.28$ GPM
20% glycol use $488 \frac{24,000}{488/10}=4.91$ GPM	20% glycol use $488 \frac{36,000}{488/10}=7.37$ GPM
30% glycol use $480 \frac{24,000}{480/10}=5.00$ GPM	30% glycol use $480 \frac{36,000}{480/10}=7.50$ GPM
40% glycol use $463 \frac{24,000}{463/10}=5.18$ GPM	40% glycol use $463 \frac{36,000}{463/10}=7.77$ GPM
50% glycol use $442 \frac{24,000}{442/10}=5.43$ GPM	50% glycol use $442 \frac{36,000}{442/10}=8.14$ GPM

Example:

Based on load calculations a given system need to deliver a maximum of 31,000 BTU with 30% glycol:

$$\text{BTU}/31,000/480=6.45 \text{ GPM}$$

(BTU/water factor=required flow rate)

NOTE:

When using **CPVC piping** it is highly recommended that you do not exceed a 25% glycol to water ratio. Environmental Stress Cracking, also referred to as ESC, may occur. Do NOT use PVC piping.

Use the required flow rate to calculate head based on the Head Flow Curve on the following page.

Minimum pump speed can be set at P53, minimum speed should not produce a flow rate in your system of less than 6 L/min and generally should not be set lower than 40%. Pump speed can be monitored at C48, 1 is lowest and 10 is highest speed. Actual water flow can now be monitored on the desktop and at C13, liters per minute. **Test at full pump speed.** 1 L/min = .264 GPM // 1 GPM = 3.78 L/min

Chiltrix Heat Pump Installation

Heat Pump Installation

Installation position

Note: Installation must be carried out by professional personnel.

The recommended mounting pad should be at least 1 ½” above ground level. If you are in an area where snow occurs, mount the unit high enough above grade to avoid blockage by drifting snow. You can consider a properly rated wall mount if desired.

Proper drainage is required at the heat pump unit to avoid flooding the outdoor unit with water or ice. Make sure condensate has a way to rapidly and completely drain away from the unit.

To install the unit on a balcony or on top of a building, the installation site must meet the allowable load bearing capacity of the building structure without affecting the structural safety. Ensure the unit is well ventilated; the direction of air exhaust should be kept away from the windows of neighboring buildings. Adequate service clearance should be kept around the unit. The unit should not be installed in places accompanied with oil, inflammable gases; corrosive components e.g. sulfur compound, or high-frequency equipment.

No obstacle in front of the unit

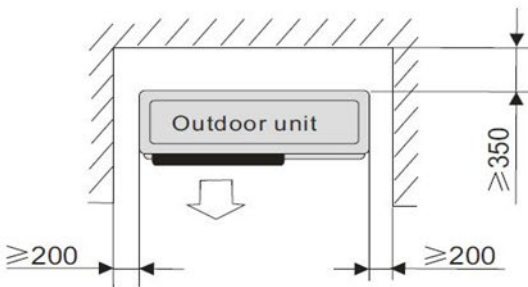

Obstacle above the unit

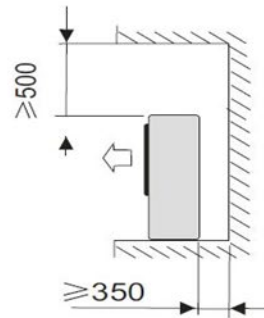

Obstacle in front of the unit

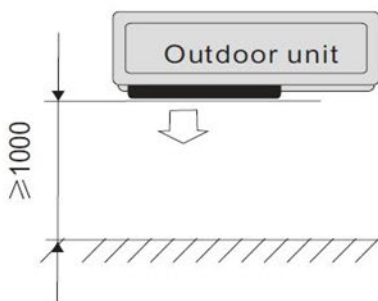

Several units in a row

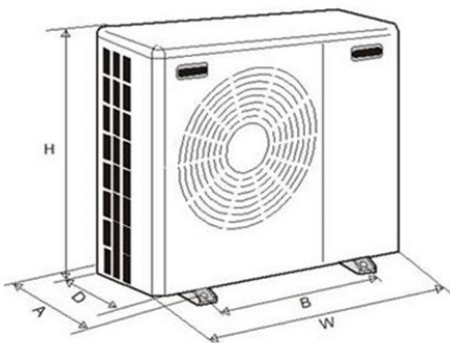
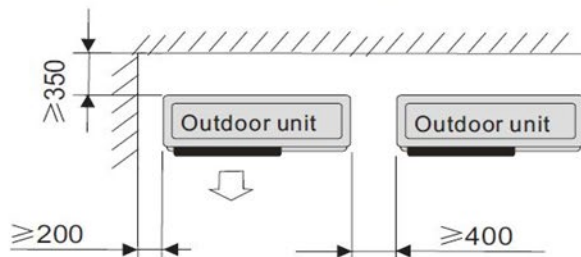

W	44"
D	16.75"
H	38"
A	17.5"
B	29.5"

Outdoor Unit Placement / Clearances
 (Unit: mm) 200mm = 8" , 350mm =14 " ,
 400=16" , 500=20" ,1000=40"

Chiltrix Heat Pump Installation

NOTE: The CX34 is shipped with the pump in a separate box attached to the top of the chiller. Please follow the directions below to install the "C4" Wilo Yonos PARA internal pump.

Internal Pump Installation

(Remove Top, Front, and Right Side Covers) **DO NOT BEND OR STRESS THE PIPING, this may case a broken joint or leak where it joins the heat exchanger.** Cut the insulation and peel it back out of the way of the flange nuts. This will allow installation of the pump without bending either of the pipes. The pump will slide in between the pipes with the washers.



Peel back the insulation



Removing the shipping spacer



Verify flow direction (UP)



Installed properly

Internal Pump Wiring

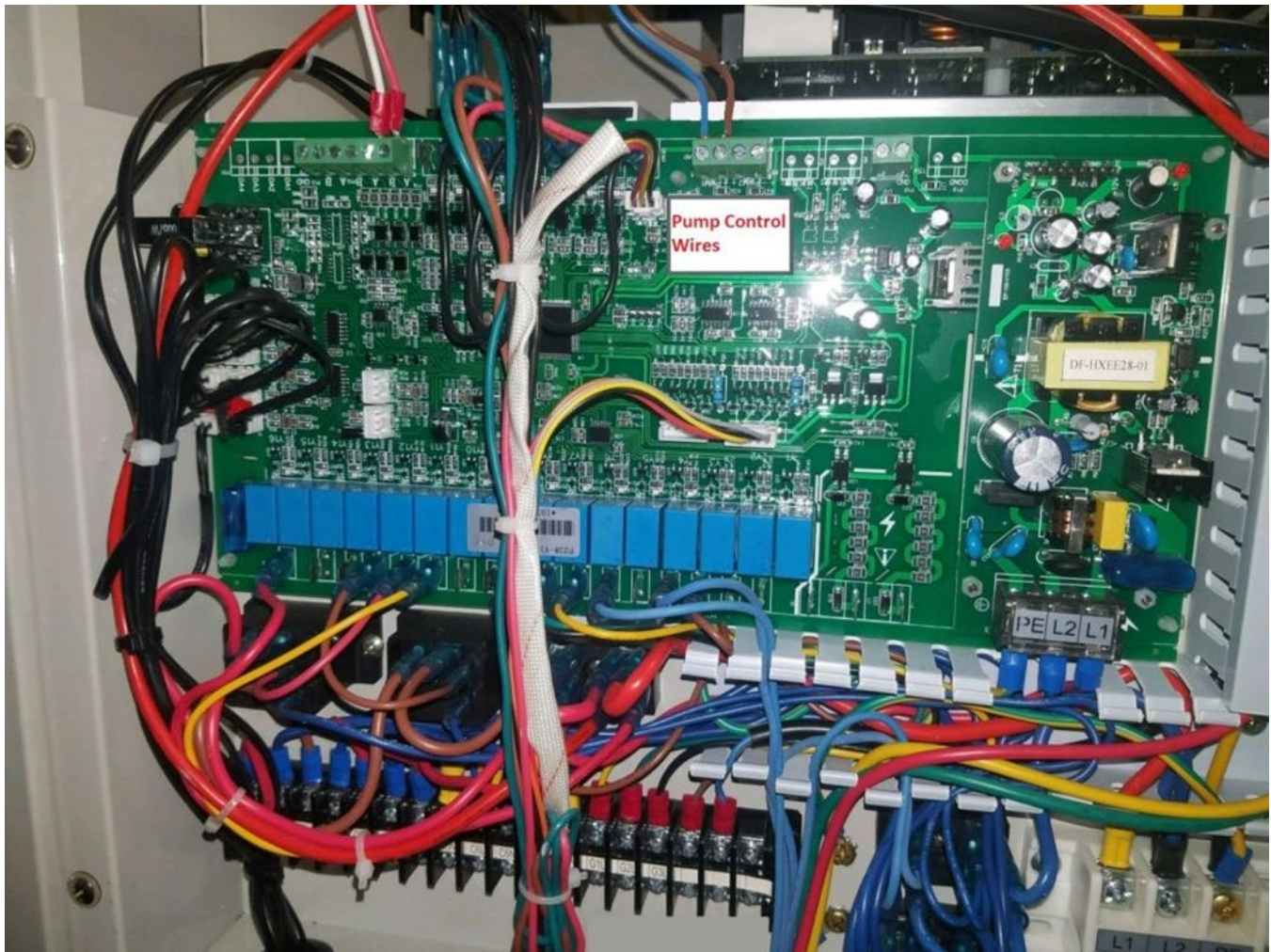

Electronics Cabinet

If the Wilo RS 25/7.5 PWM pump does not have the required flow rate, a second Wilo RS 25/7.5 may be added to increase the total pump pressure and flow. This will double the head pressure capability at the targeted flow rate. When adding a booster pump, wire both power and control wires in parallel with the internal Wilo pump wiring. Use the same terminals. See diagrams next page.

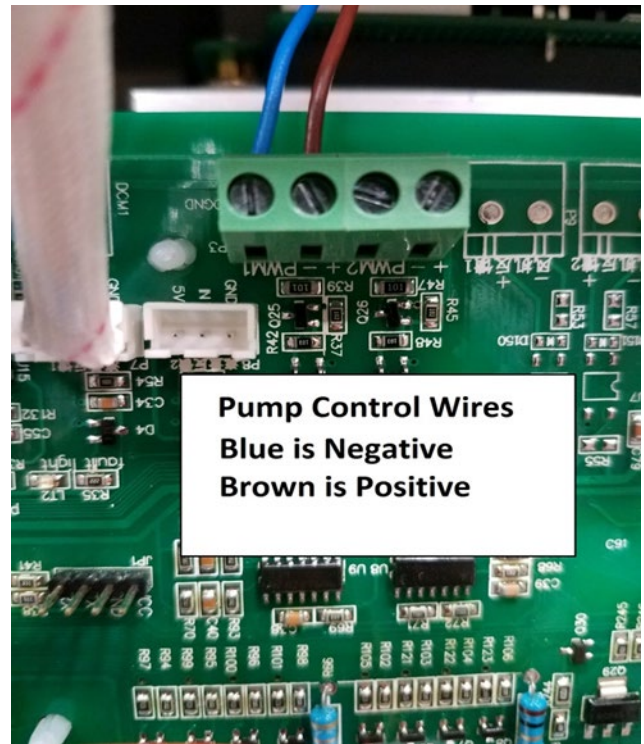
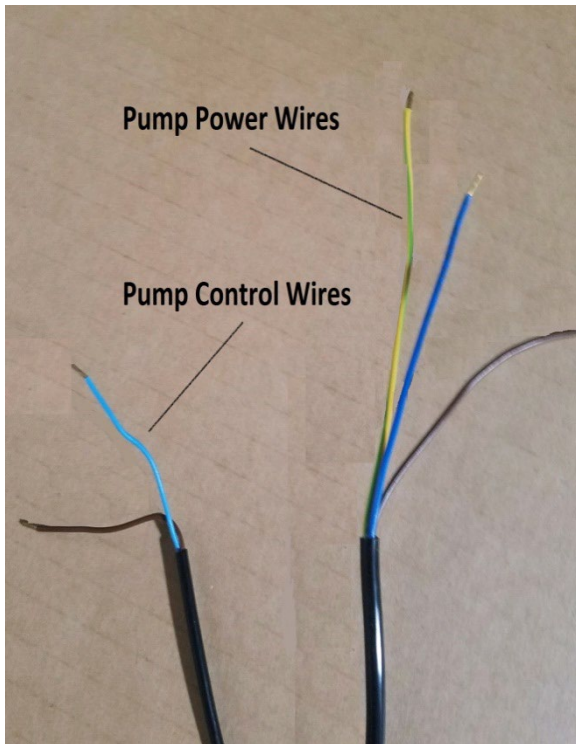

The blue and brown pump **CONTROL WIRES** are connected to the (+ & -) on the PWM1 terminal connector at the top or the main control pcb.



Pump **POWER** wires.

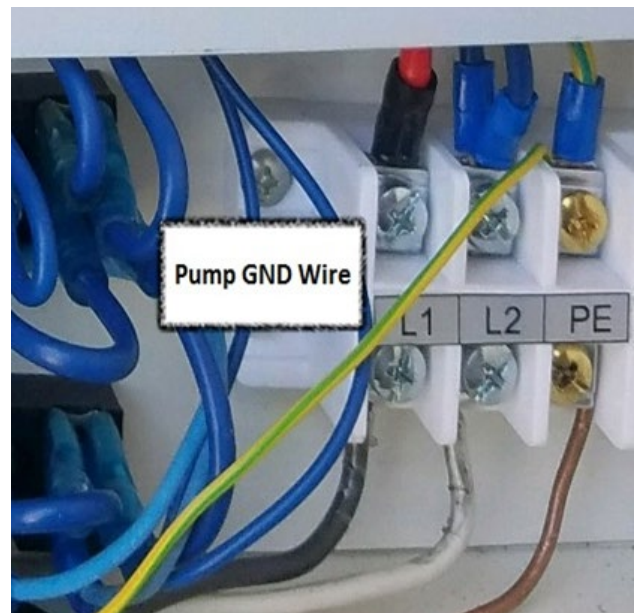

Pump **GROUND** wire.

Electrical Connection

General

Note!

Electrical installation and service must be carried out under the supervision of a qualified electrician. Electrical installation and wiring must be carried out in accordance with the NEC.

The heat pump must be connected under the supervision of a qualified electrician. Wires, spare parts and materials etc. must satisfy the relevant standards and codes issued by the host country or region. The heat pump does not include an AC disconnect or switch on the incoming electrical supply which will be required. The power supply cable must be connected to a circuit-breaker with at least a 3 mm breaking gap. Incoming supply must comply with the technical requirements, with a frame ground wire (neutral is not used), via a distribution box with breakers. **Allowed Voltage range is 208-240vac. Maximum current draw is 13 amps, minimum wire size is 12 AWG, minimum breaker size is 20 AMP. It is advisable to add surge suppression with transient voltage protection to the circuit powering the chiller.**

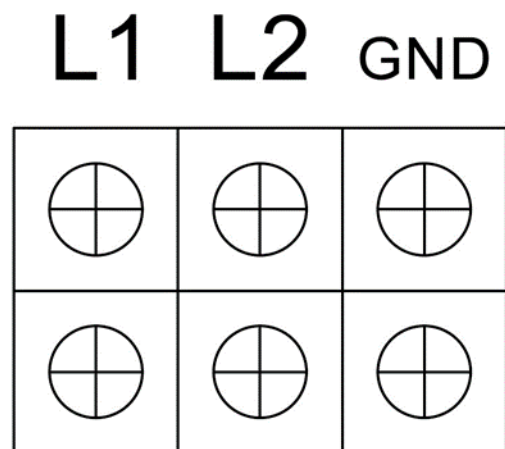
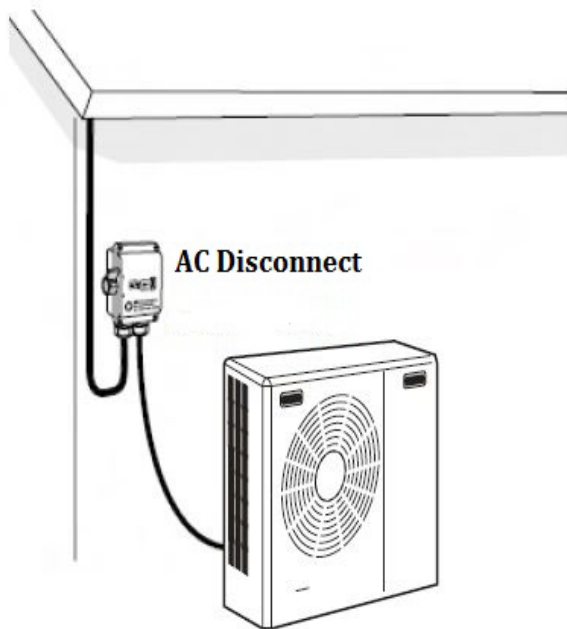

Main terminal block inside electronics box

Example MOV transient voltage suppressor

<https://www.mouser.com/?Keyword=V300LA40AP>

Electric Connections and Component Locator

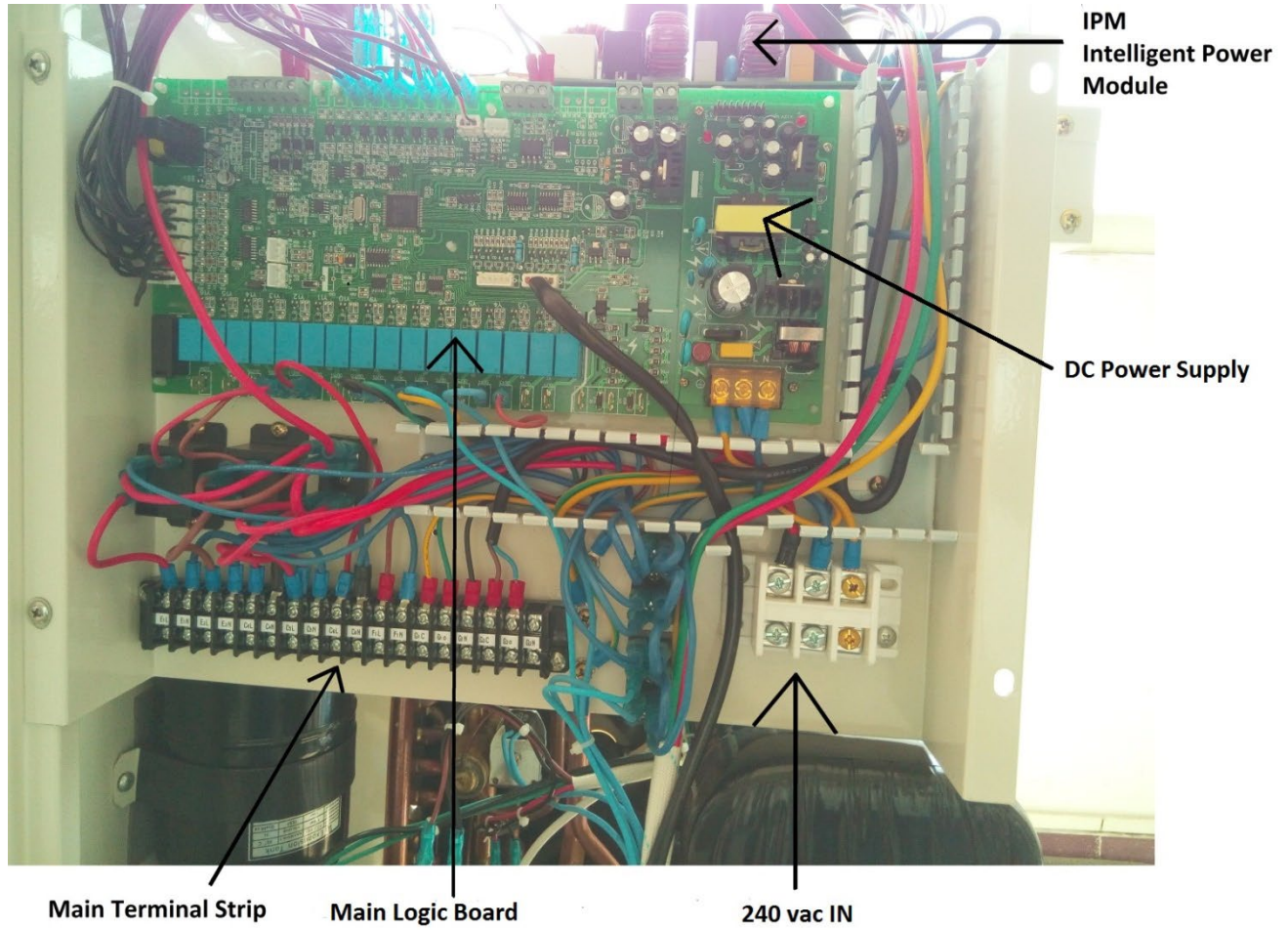

CX34 System Wiring Diagram

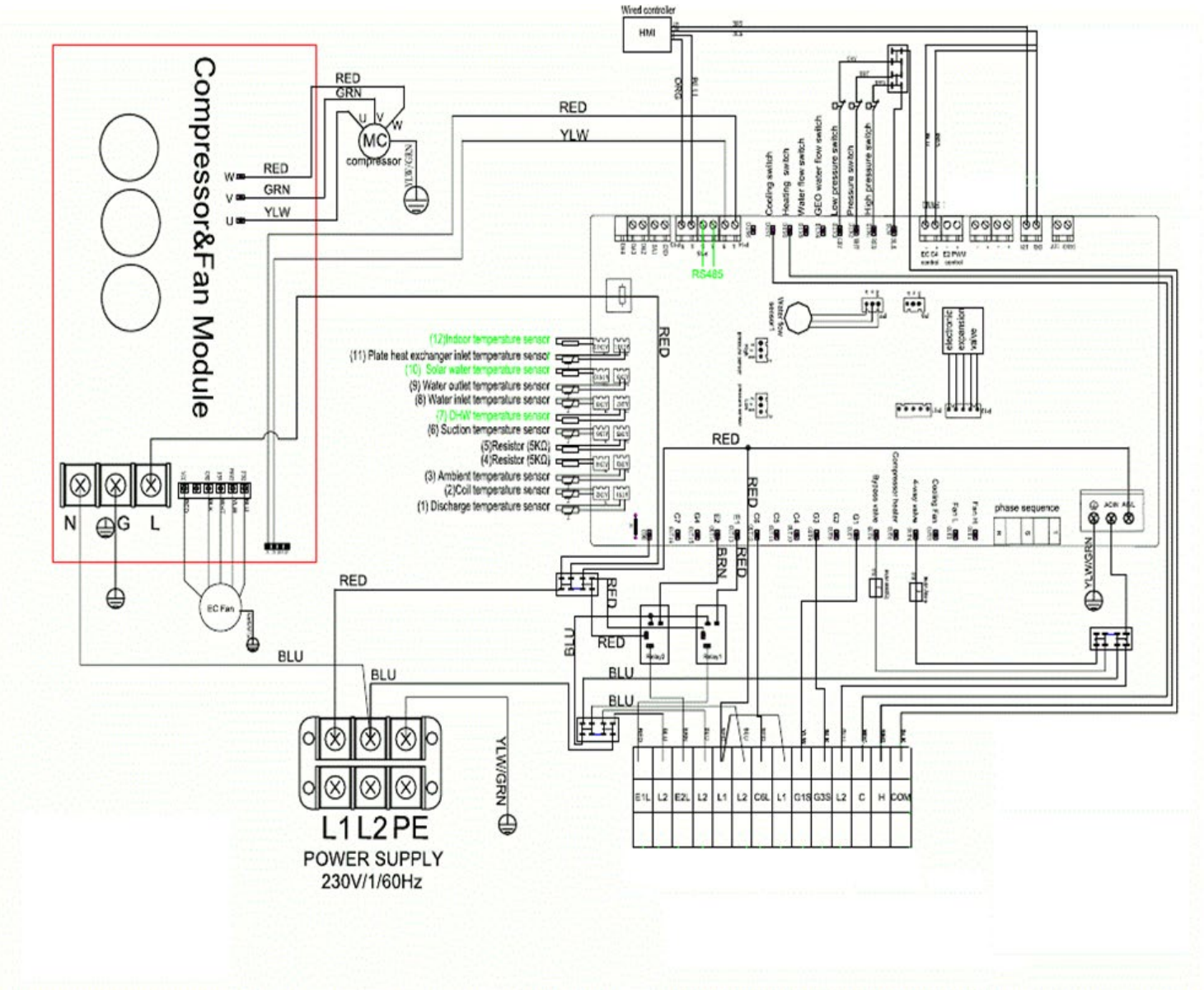

When using a second NON-PWM water pump

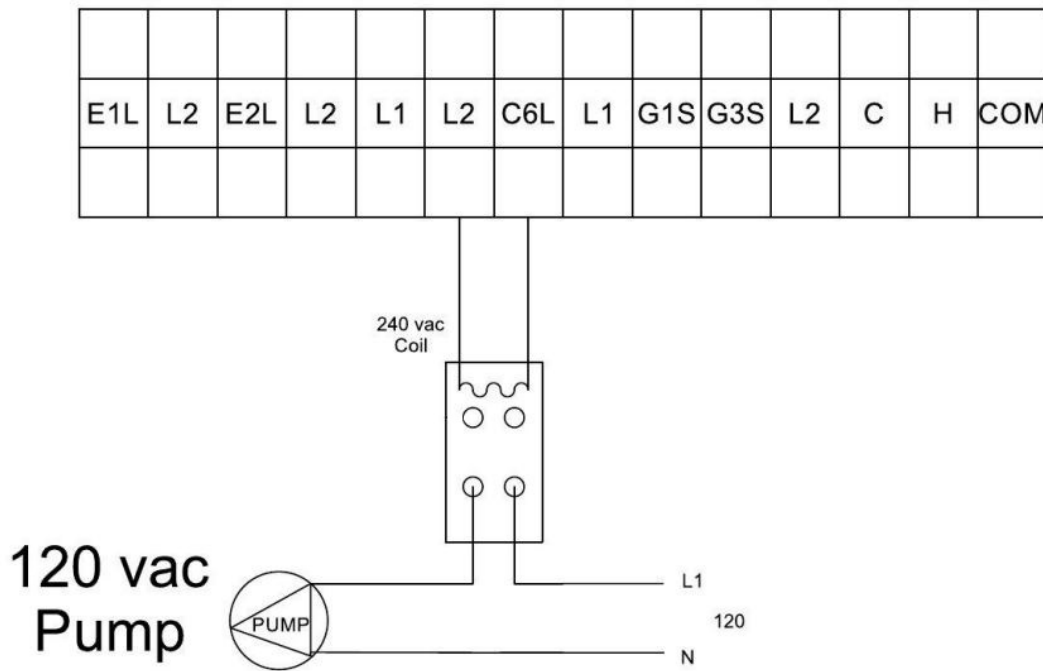

Connect the fixed speed pump to L2 and C6L.

When using a second NON-PWM water pump, use terminals L2 and C6L for relay coil power only. Do not connect a pump directly to L2 and C6L, always use a relay with a 240 vac coil. This pump will only run when the PWM pump is running. Setting P51=0, P54=0 and P52=1, will shut C6 off when the chiller reaches its set point.

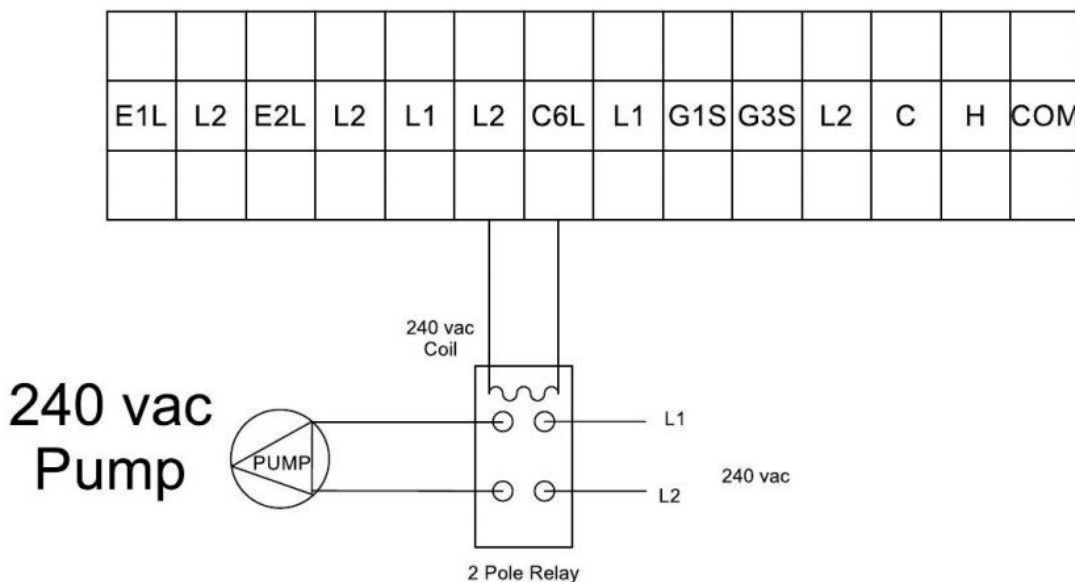

DHW (Domestic Hot Water) G1 Valve

G1: DHW/AC / Heating 3-Way Valve

In DHW mode, the G1 valve is powered off. In AC/heating mode, G1 is powered on. Parameter P08 must be "0" to enable DHW, C19 will show the switch status.

G1 and G3 valves use 220v Primary from the CX34. Use conduit and install per local code.

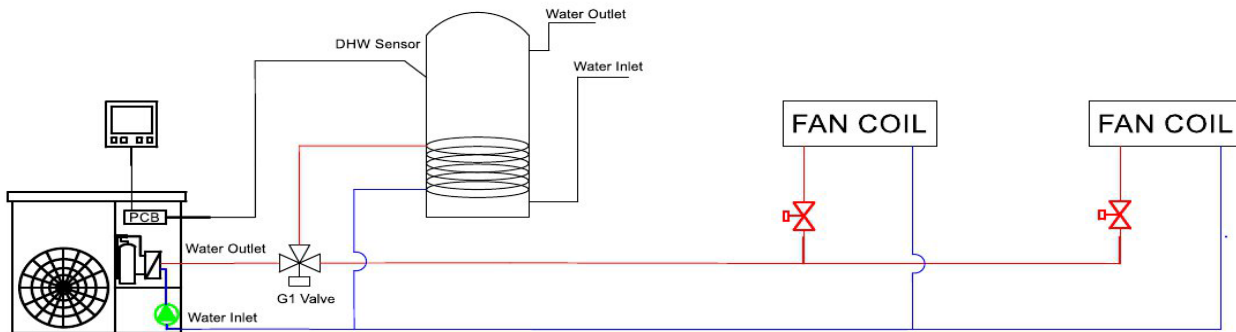

DHW target setting temperature is the tank water temperature measured with the DHW sensor, not the CX34 inlet water temperature. If the target temperature is 122°F, (refer to page 43 to set the DHW temp), and the differential is 2°C, it means, when the DHW tank reaches 122°F, the compressor will stop. When the DHW tank temperature is lower than 119°F, the compressor will start. **See the Chiltrix Tank Manual before proceeding to install or connect any DHW or buffer tank.**

See the Chiltrix Tank Manual for important details and options for using CX34 with DHW, including backup heat options, and anti-legionella function. READ THE CHILTRIX TANK MANUAL BEFORE DESIGNING, CONNECTING, CONFIGURING, OR USING DHW.

Note*

There is one sensor taped to the outer CX34 plastic wrapper with the rubber feet, it is for the DHW tank.

The indoor ambient air temp is not used at this time, however, **do not disconnect this sensor. Leave all unused sensors plugged in and wrapped in the bundle above the compressor.**

IMPORTANT

Check all tank ports including under any element covers to make sure any unused ports are plugged. Pre-plugged ports may be only finger-tight. Check ALL ports and plugs for water tight fit.

DHW (Domestic Hot Water) G1 Valve

DHW and AC / Heating with two chillers in Parallel

G1 and G3 valves use 220v Primary from the CX34. Use conduit and install per local code. Below shows 2x G1 valves, used this way so that Chiller 2 can continue to provide cooling or heating while Chiller 1 deals with any DHW load. Bottom drawing shows 1x CX34 properly used with only one G1 valve.

The G1 valve should be installed as close to the CX34 as practical. The DHW tank should be installed as close to the G1 valve as practical. Shorter distances will improve performance and reduce the likelihood of needing a booster pump.

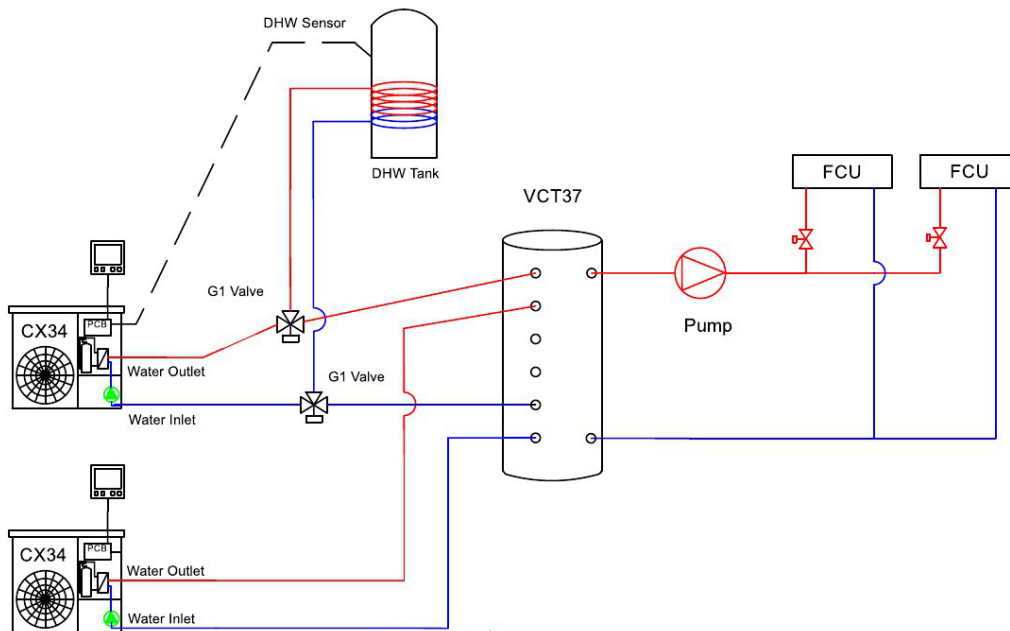

IMPORTANT

Check all tank ports including under any element covers to make sure any unused ports are plugged. Pre-plugged ports may be only finger-tight. Check ALL ports and plugs for water tight fit.

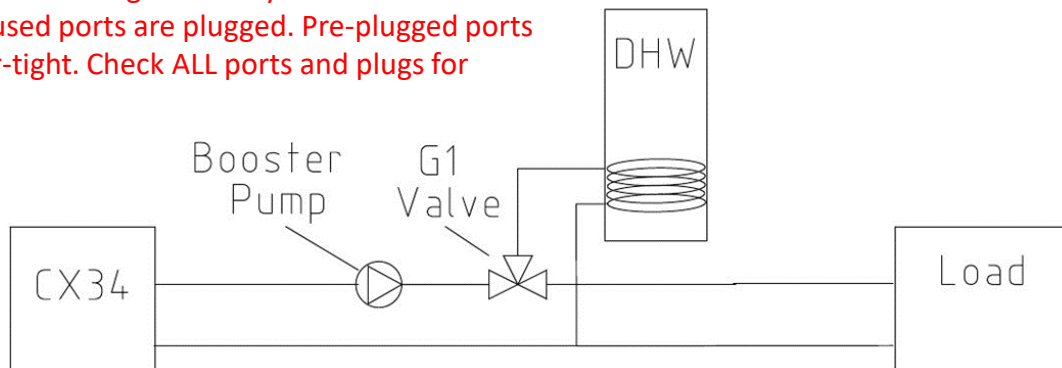

G valves Continued

A booster pump may be installed in front of the G1 valve when installing the DHW option if the head, including pressure drop of the DHW tank coil, exceeds the head allowed by the pump curve when calculated at 7GPM. If a booster pump is needed for a different reason, this location should also be used. Check the DHW tank pressure drop from the Chiltrix Tank Manual or tank provider coil specs if not using a Chiltrix tank. The G1 valve should be located as close to the CX34 as practical.

G1 Valve Wiring and Parameters

G1 and G3 valves use 220v Primary from the CX34. Use conduit and install per local code.

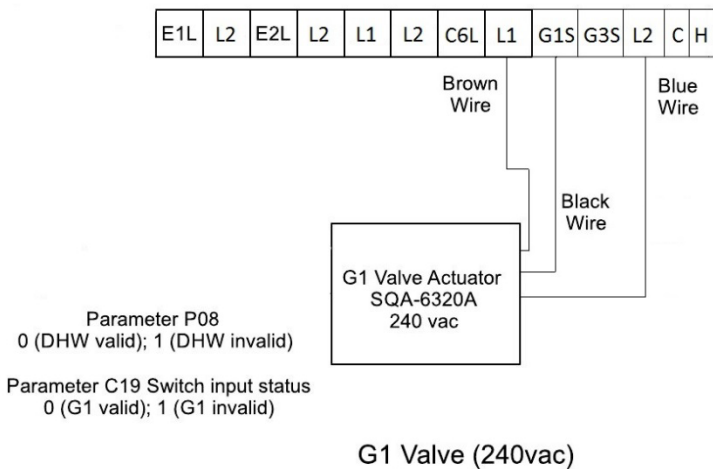

Be sure to review this document and follow the proper procedure for all rubber oring/gasket fittings. The recommended lubricant is silicon grease. If the rubber is not lubricated then the oring/gasket will tear.

<https://www.chiltrix.com/documents/Chiltrix-3-way-valve.pdf>

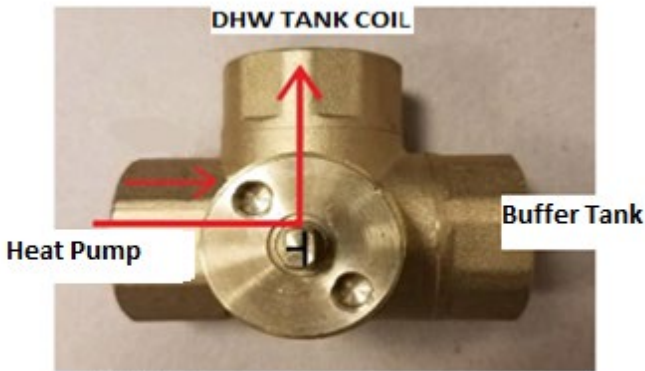

Figure 1
G1 Valve Active, DHW Mode

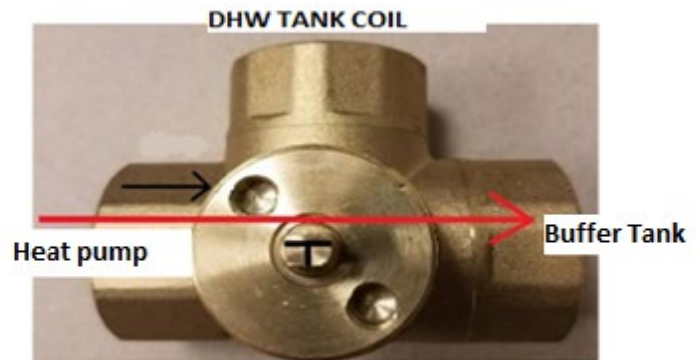
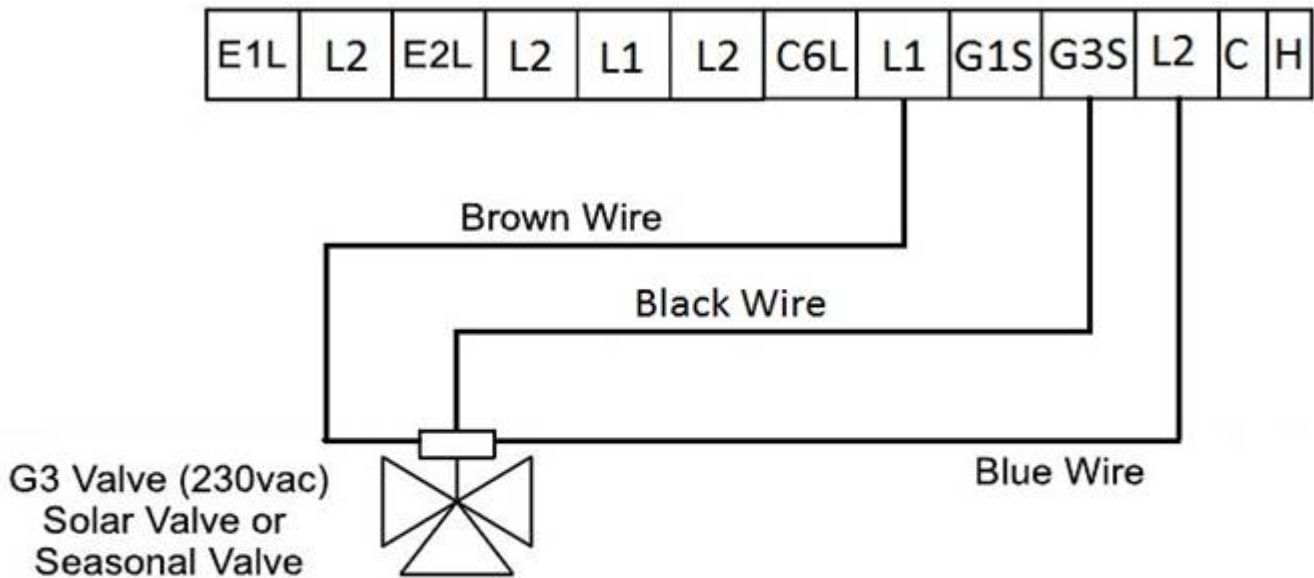

Figure 2
Heating and Cooling Only

Figure 1, this is the direction of flow when it is activated for DHW. Figure 2, this is the direction of flow when it is activated for Heating or Cooling. When the brown wire is connected to L1, the blue wire connected to L2, and the black control wire is connected to G1S the valve is controlled by voltage at L2 and G1S. Voltage at G1S activates the valve for DHW. No voltage at G1S activates the valve for Heating/Cooling. See wiring diagram above. **Note: Use the center "T" screw as a visual cue for valve position.**

G3 Valve: Seasonal Switch Valve

G1 and G3 valves use 220v Primary from the CX34. Use conduit and install per local code.



When Parameter P50 is 0, G3 is Configured as a Seasonal Switch

When Parameter P50 is 1, G3 is Configured as a SolarPerheat Valve

The G3 port can be used to control a seasonal switch valve. The seasonal switch valve is used to isolate the floor coils from the fan coils when switching over from heating to cooling. The seasonal switch valve is controlled by parameter P50. When parameter P50 is 0, the valve is configured as a seasonal Switch.

When parameter P50 is 1, the valve is configured as a solar pre-heat valve. The CX34 compares the solar tank temp and AC returned temp. When the solar tank temp – AC returned temp is ≥ 5 °C, the 3-way valve G3S will be on; when solar water tank temperature minus the air conditioning returned temperature is less than 2°C, G3S will be off.

G3 VALVE Seasonal Switch Valve

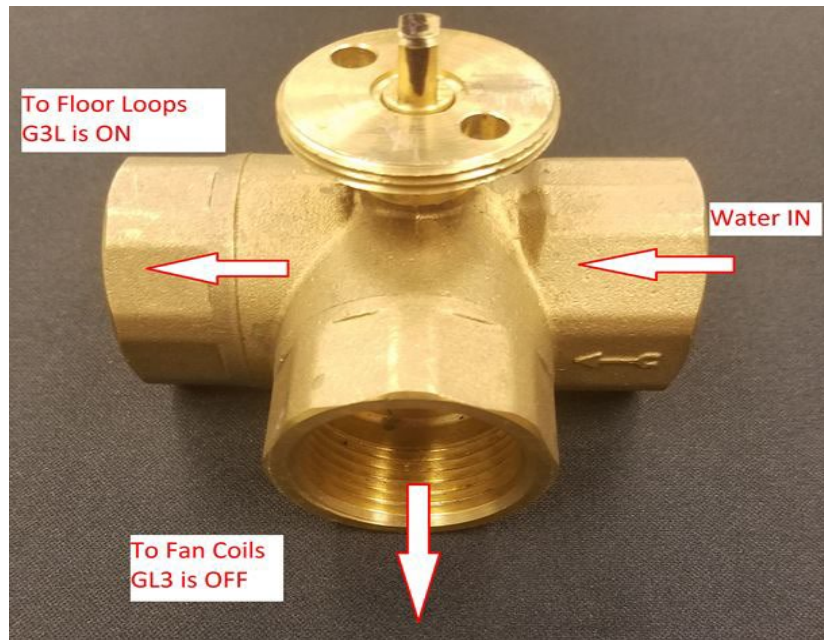
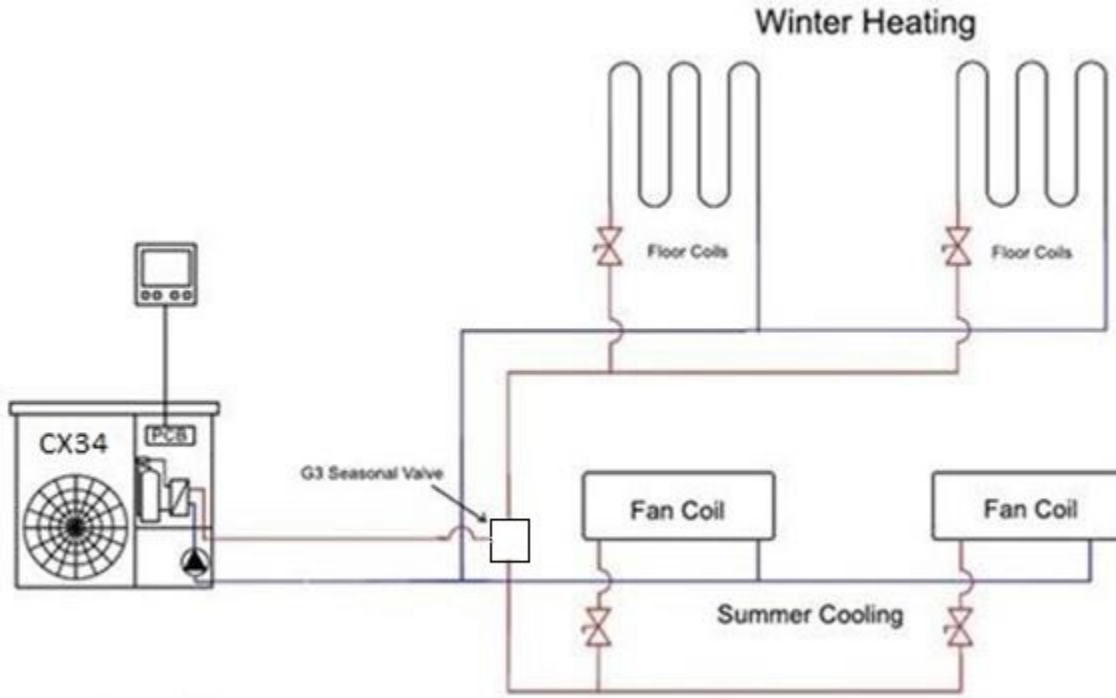

G3 Ports

Second Heat Source

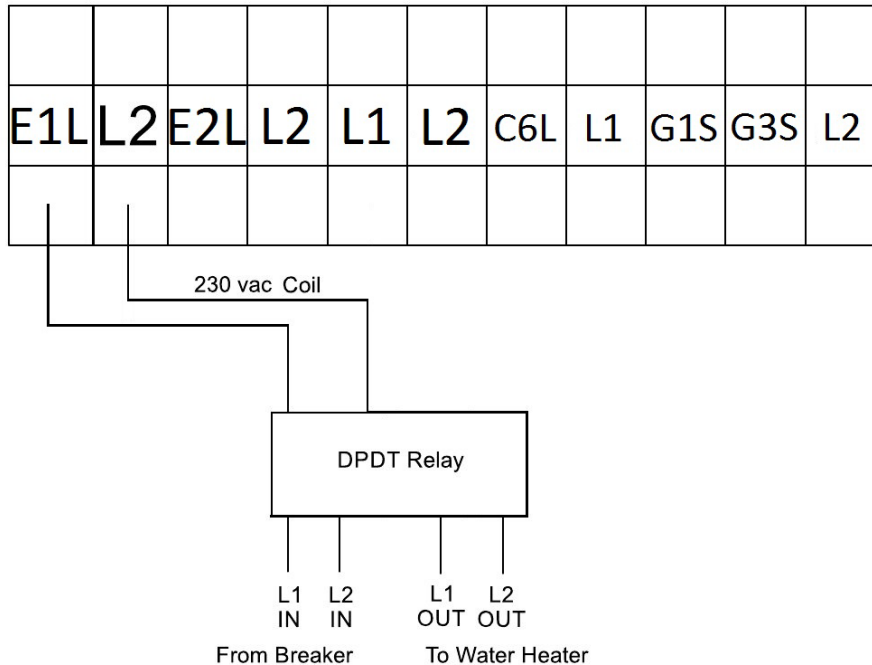

This is used by customers that don't use V18 for backup heating. IT REQUIRES A STANDARD ELEMENT AND THERMOSTAT TO BE INSTALLED ON THE INLINE TANK USED FOR BACKUP HEATING. **DO NOT USE A BUFFER TANK FOR BACKUP HEATING. SEE CHILTRIX TANK MANUAL.** This would typically be a small inline tank located on the supply side of the loop, between the CX34 outlet and the first of any load inlets. The thermostat/element must be set to max 120F and any such tank used for this purpose must have code-compliant pressure relief valve installed and properly vented via copper pipe to a drain.

NOTE- in the application the E@ backup heat only allows/denies power to the standard tank thermostat control. The tank thermostat controls the element.

NOTE* THE PREFERRED WAY TO ADD BACKUP HEAT IS TO USE THE CHILTRIX V18 DYNAMIC VARIABLE BACKUP HEATER. "SECOND HEAT SOURCE" IS AN OLDER AND MORE COMMON METHOD, BUT IS NOT AS EFFICIENT AS A V18.

Parameters 56, and 58

When P56=1, the 2nd heat source function is valid. E2 will be controlled by P58 setting. When the air temp is < P58, E2 is on, the compressor is off, all water pump and water valves will be working as normal. When the air Temp > P58 5C, the compressor will be on and E2 off. E1 will not activate during defrost.

Onboard External Relay/T-Stat Control

The internal T-Stat allows a heat pump thermostat or other external controller to control switching the heating, cooling and standby modes of the CX34 via relay. This method of control generally requires a single-stage standard heat pump thermostat, a installer provided 24 vac transformer and two relays, (Eg. Tyco K10P-11A15-24, w/ two relay sockets, 27E487). The relays can be located in the chiller next to the IPM. The transformer can be located in the home near the standard thermostat or other controller.

NOTE: THIS SHOULD NEVER BE USED FOR A HEATING OR COOLING "CALL". IT IS ONLY FOR MODE SELECTION. Heating or cooling calls are not needed or allowed with CX34, as it monitors the returning water temperature and always knows what it needs to do.

IMPORTANT
The C,H, Com terminals are DRY CONTACTS. Do NOT apply Voltage to the contacts. Only connect relays as explained.

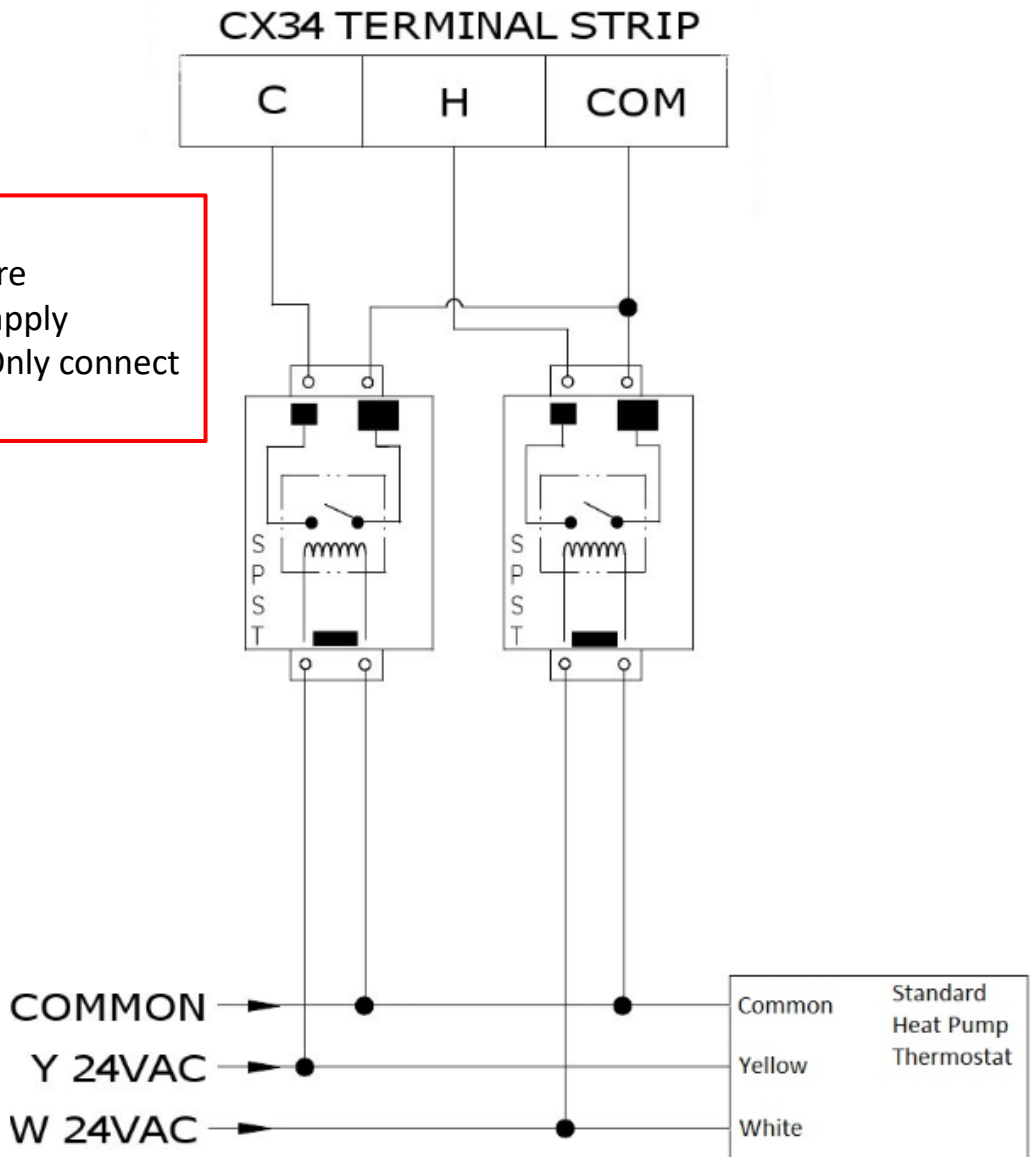

Onboard External relay Control – Cont'd

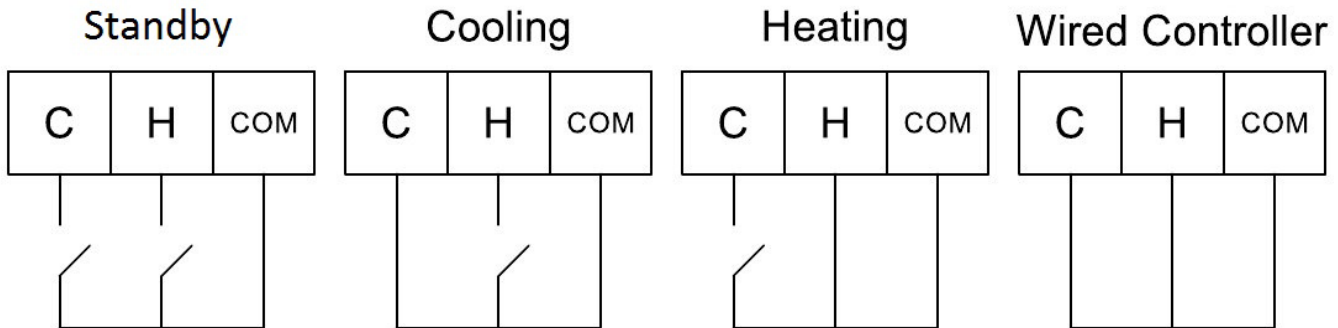

Once the relays are wired as shown, the CX34 DIN setting must be changed

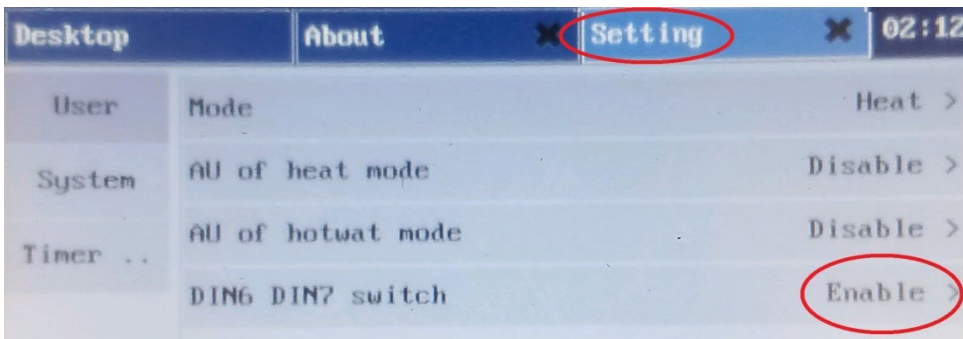

IMPORTANT
The C,H, Com terminals are DRY CONTACTS. Do NOT apply Voltage to the contacts. Only connect relays as explained.

“Enable means “Enabled”
“Disable means “Disabled”

NOTE: RELAY CONTROL SHOULD NEVER BE USED FOR A HEATING OR COOLING “CALL”. IT IS ONLY FOR MODE SELECTION. Heating or cooling calls are not needed or allowed with CX34, as it monitors the returning water temperature and always knows what it needs to do.

Disabling DIN6 & DIN7 will allow the standard CX34 controller and/or Psychrologix Controller to have control and will disable relay control.

The switch status can be displayed in the C parameters

C63 is DIN6 AC heating switch mode status; 0=OPEN; 1=CLOSE

C64 is DIN7 AC cooling switch mode status; 0=OPEN; 1=CLOSE

NOTE: Using this relay control option will override inputs from the Chiltrix standard wired controller and/or Psychrologix controller until DIN 6/7 is restored to its disabled setting.

See the Psychrologix manual for important additional information if this applies to you.

Timers as explained elsewhere in this manual will NOT be available when relay control is used.

System filling with Propylene Glycol and water

At or near the CX34 a flush/fill valve assembly must be installed. This can be made with three ball valves and a couple hose fittings. See example below.

Bill Of Materials

- 2 ea. 1" x 3/4" tee
- 1 ea. 1" Ball Valve
- 2 ea. 3/4" Ball Valve
- 2 ea. 3/4" Hose Fittings
- 10' of Garden Hose
- 5 Gallon Bucket
- High Head Fill Pump

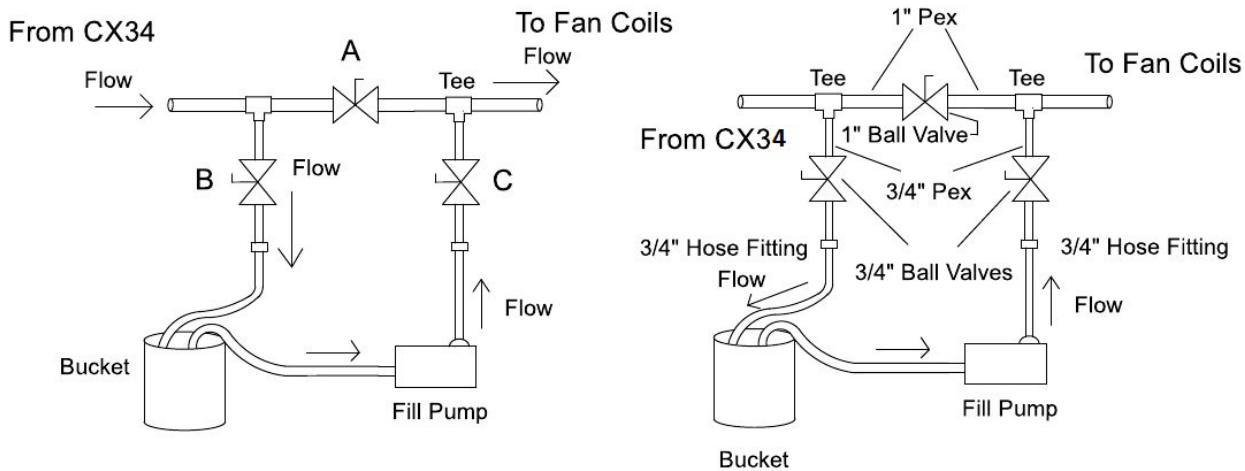

Pre-mix the propylene glycol in a container large enough to hold the loop volume plus a few gallons. Using a filling pump and 3 hoses, place one hose in the glycol container and connect it to the suction side of the pump. Connect the second hose to the pump discharge and the other end to valve "C" that is closest to the fan coils. Using a third hose, connect it to valve "B", closest to the chiller and leave the open end in the glycol bucket. Close the middle ball valve "A". Close the middle ball valve "A". The pump should be pumping away from the CX34 chiller. Open and close valve "A" a few times to remove trapped air. The pump should be pumping away from the CX34 chiller.

Run the pump until there are no more air bubbles coming out of the loop. After all air is expelled from the loop, close valve "B" and then open valve "A" with the pump running. When the pressure gage on the CX34 shows at least 30 psi close valve "C" and turn off the pump. Minimum loop pressure is 14.5 psi, maximum pressure is 43.5 psi, and ideal pressure is 20-30 psi.

Purging Air From DHW Tank & Fan Coils

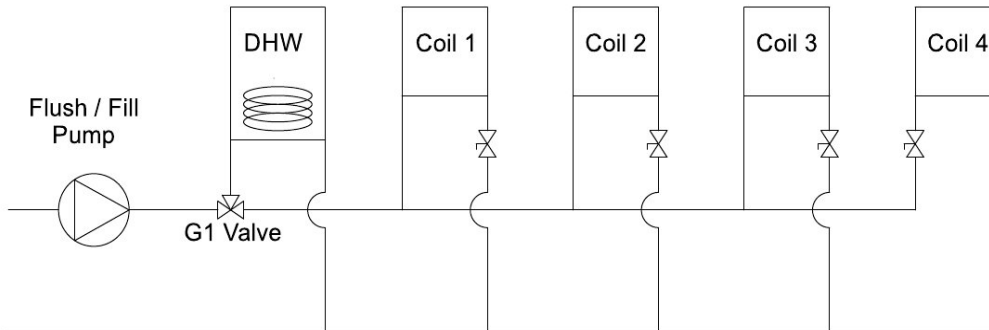

If a DHW tank is installed, it should be the first device on the loop as shown. The G1 valves should always be as close to the CX34 as possible. The tank should be as close to the G1 valve as possible.

To purge the air from its coil, remove the actuator from the valve body and rotate the valve stub 90° clockwise to force the water through the coil. Return the valve stub back to its original position when all of the air is purged. Close the input valve to each fan coil except the first coil (1). Turn the pump on and run it, when the bubbles stop coming out of the discharge hose turn on the ball valve on coil (2), wait for the bubbles to stop, then do the same for coil number (3), then (4). All CX Chillers have a flow switch installed in the loop. Air in the system may cause a flow switch alarm; the controller will display a P5 error code.

All CXI fan coils have an air purge screw near the water inlet port, always purge the fan coils before starting the chiller. The CX34 chiller also has a bleeder valve with a ¼" clear tube attached to it located near the brazed plate heat exchanger.

Fan Coil Flow Balancing (Performed at time of commissioning)

Proper and even flow through each fan coil is important for both heating and cooling. This can be done with balancing valves or ball valves installed at each fan coil supply or return pipe. This must be done with the CX34 in heating mode, set loop AC target to the maximum temp setting for commissioning.

DO NOT DO THIS IN COOLING MODE OR DAMAGE MAY OCCUR.

Adjust valve positions until each fan coil has the same leaving fluid temperature, with all CXIs set to max manual fan speed and in heating mode. When all leaving fluid temps are the same, the units are properly balanced. If a fan coil is powered on but the fan isn't running, there is a good possibility that there is air trapped in that particular part of the loop. Also verify the parameters with the CXI FCU manual, page 34. <http://www.chiltrix.com/documents/Chiltrix-hydronic-FCU-ver-1.5.pdf>

Note – while only one valve per CXI is needed for balancing, best-practice would be to use 2 valves, one on supply and one on return, so that the fan coil unit could be isolated if needed.

Standard Controller (Included with all Cx34 Units)

1. Functions and features

Cooling, Heating, DHW, cooling + DHW, heating + DHW mode of operation options, automatic fault detection, alarm processing, and energy control.

1. The 4-conductor control cable can be extended up to 300 feet of 20 AWG or larger.
2. The controller handles all input and output signals, and system status to ensure that the unit is stable and reliable.
3. Full-touch color LCD display.
4. Modes and other factory parameter settings are entered directly on the LCD screen.
5. 100 fault records can be stored and retrieved to show the details of each fault that may occur.
6. All of the switch input / outputs can be directly observed on the LCD control panel making commissioning convenient.
7. The LCD display is wall-mountable.

Indoor Controller!

This controller must be installed indoors.

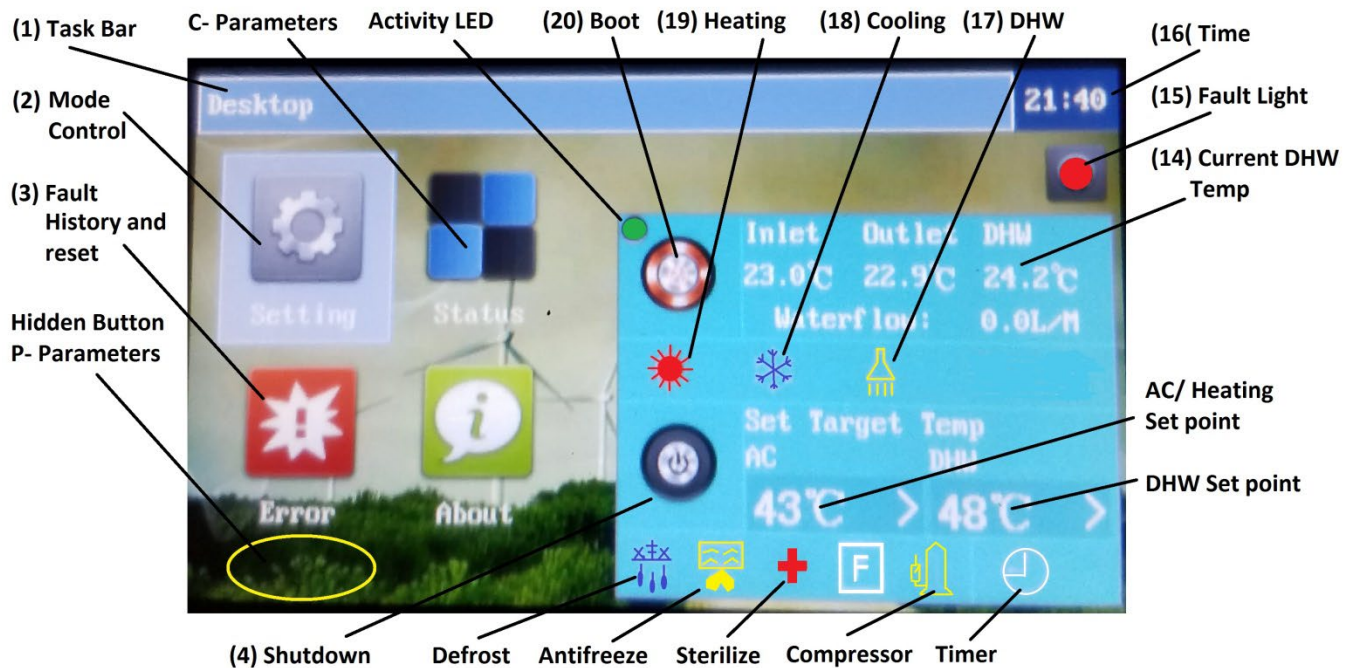

- (1) **Taskbar:** shows the current running applications, and the time. Clicking on the different application boxes will switch to different applications.
- (2) **Main window:** Displays the main window of the application that is currently running.
- (3) **Application icon:** A desktop application that first highlights the icon when it is first clicked, and then clicked again to launch the application.

Indoor Controller!
This controller must be installed indoors.

Standard Controller (cont'd)

- (4) **Shutdown button:** Used to execute the **shutdown command**, when clicked it will pop up a confirmation window, click "OK" to execute the boot command, or click "Cancel" for no action.
The shutdown command is used to take the chiller out of heating or cooling mode.
- (5) **Defrost:** Is illuminated when system is in the Defrost State.
- (6) **Antifreeze:** Is illuminated when system is in the antifreeze mode.
- (7) **Sterilization:** Is illuminated when system is in the sterilization mode.
- (8) **Ground source heat pump:** N/A
- (9) **Compressor:** Illuminated when the compressor is on.



Figure 1-2

- (10) **AC temp setting:** Temperature setting in the air conditioning mode (cooling or heating), touch the "SET TARGET TEMP" icon and the keyboard window will pop up, as shown in Figure 1-2, then, enter the required temperature. Use the "ENT" key will confirm the input. Use the "DEL" key to delete the input, and the "ESC" to cancel the input and exit.
- (11) **DHW temperature setting:** Sets the temperature in the (DHW) mode.
- (12) **AU heat:** Not used, please disable unless using **Dynamic Outdoor Reset (P. 57)**.
- (13) **AU DHW:** Not used, please disable.
- (14) **Current DHW temperature:** This is used to check the current DHW mode temperature.
- (15) **Fault light:** Illuminated if there is a fault.

Standard Controller (cont'd)

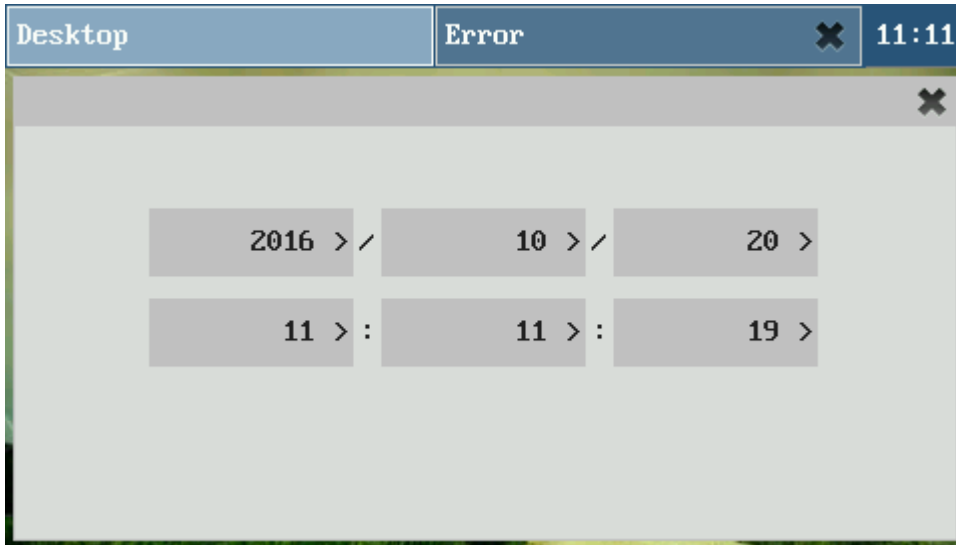

Figure 1-3

Figure 1-3

- (16) **Time:** Used to display and set the current time. When clicked, a pop-up showing the date and time is displayed, Figure 1-3. From left to right, and from top to bottom is the year, month, day, hour, minute, and second. Clicking on each box will allow you to set its value.
- (17) **DHW:** If the hot water mode is enabled, this icon will be lit.
- (18) **Cooling:** If the cooling mode is on in the user setting, this icon will be lit.
- (19) **Heating:** If the heating model is on in the user setting, this icon will be lit.



Figure 1-4

- (20) **Boot button:** Used to execute the boot command operating mode.

1. SETTING PASSWORDS (Optional and Not Recommended)

The application is used to set the user parameters, and set a password, as shown in Figure 1-5, minimum of 6 characters, maximum of 127.

Standard Controller (cont'd)

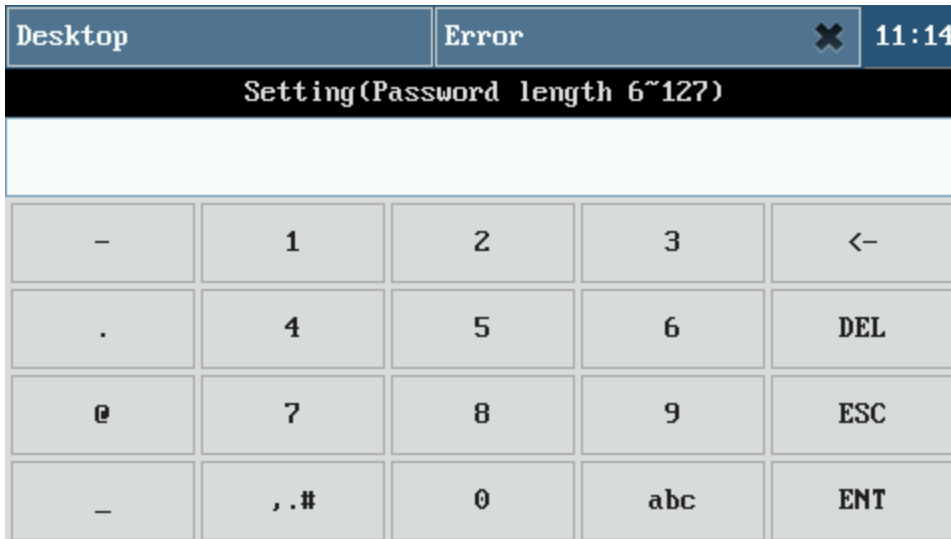

Figure 1-5

Description of the keypad function keys:

- “<-”: Backspace key, used to delete a character.
- “DEL”: Delete key, used to delete all characters.
- “ESC”: Exit key, used to exit the input state.
- “ENT”: ENTER key to confirm an input.
- “abc”: Toggles key for switching to lowercase alphabetic keyboards.
- “ABC”: Toggle key for switching to uppercase alphabetic keyboards.
- “123”: Numeric keypad toggle key for switching to the numeric keyboard.
- “,.#”: Symbol Keyboard toggle key for switching to the symbol keyboard.

Note: The password can be composed of numbers, letters, symbols, etc., the factory default password is empty, and any 6 characters can be used.

Note: The password can be composed of numbers, letters, symbols, etc., **the factory default password is 600000.**

Consider writing the password on the back of the controller.

NOTE: Chiltrix technical support has no easy or simple way to reset this password for you. If you decide to use a password, make sure to write it down and keep it in a secure location.

Standard Controller (cont'd)

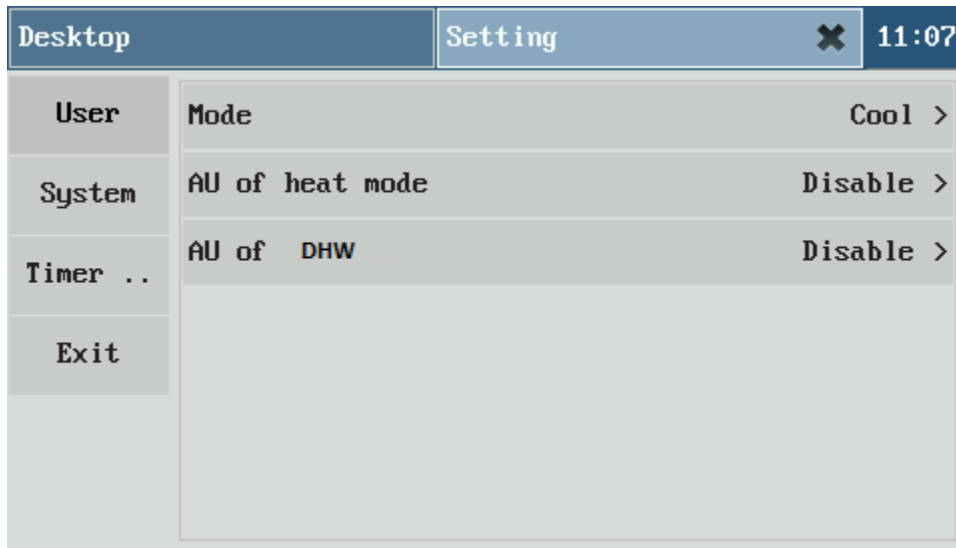

Figure 1-6

After the password is entered correctly, as shown in Figure 1-6, The Mode may be set, click "Exit" in the main menu or "X" in the task bar to exit the application.

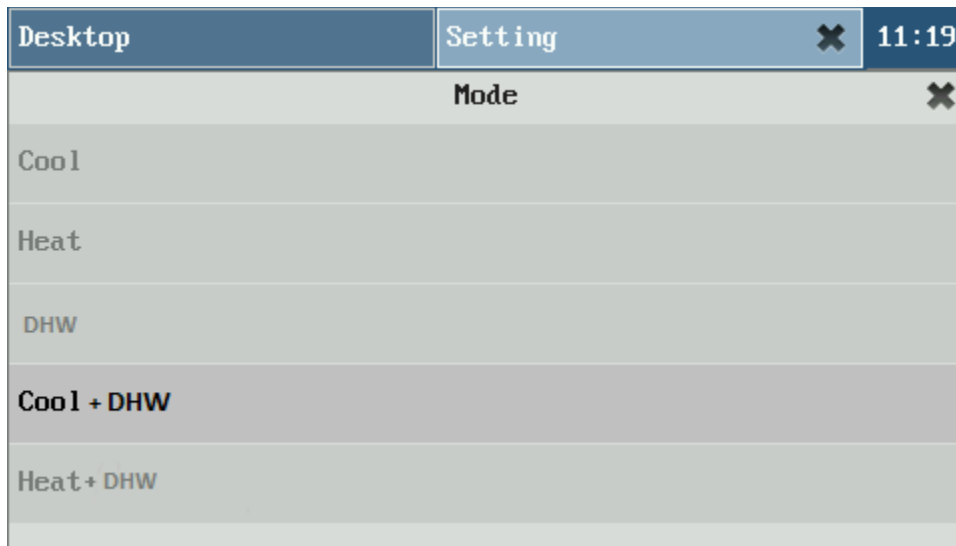

Figure 1-7

1.2 USER PARAMETERS (Figure 1-7)

- Operation mode: Set the units' operation mode.
- Five optional modes: cooling、heating、DHW、cooling + DHW、heating + DHW

1.3 SYSTEM

- Language: Default is English.
- Screensaver: Sets the screen saver pop-up time.
- Buzzer: Disables or uses the buzzer sound when the unit has an alarm.
- Date & Time: you can set the machine date and time.
- Password setting: Set the password to enter applications.

Standard Controller (cont'd)

1.3 SYSTEM

- Language: Default is English.
- Screensaver: Sets the screen saver pop-up time.
- Buzzer: Disables or uses the buzzer sound when the unit has an alarm.
- Date & Time: you can set the machine date and time.
- Password setting: Set the password to enter applications.

1.4 Machine Timing Switch

The timer functions can be found under “Settings” then Timer ON/OFF.

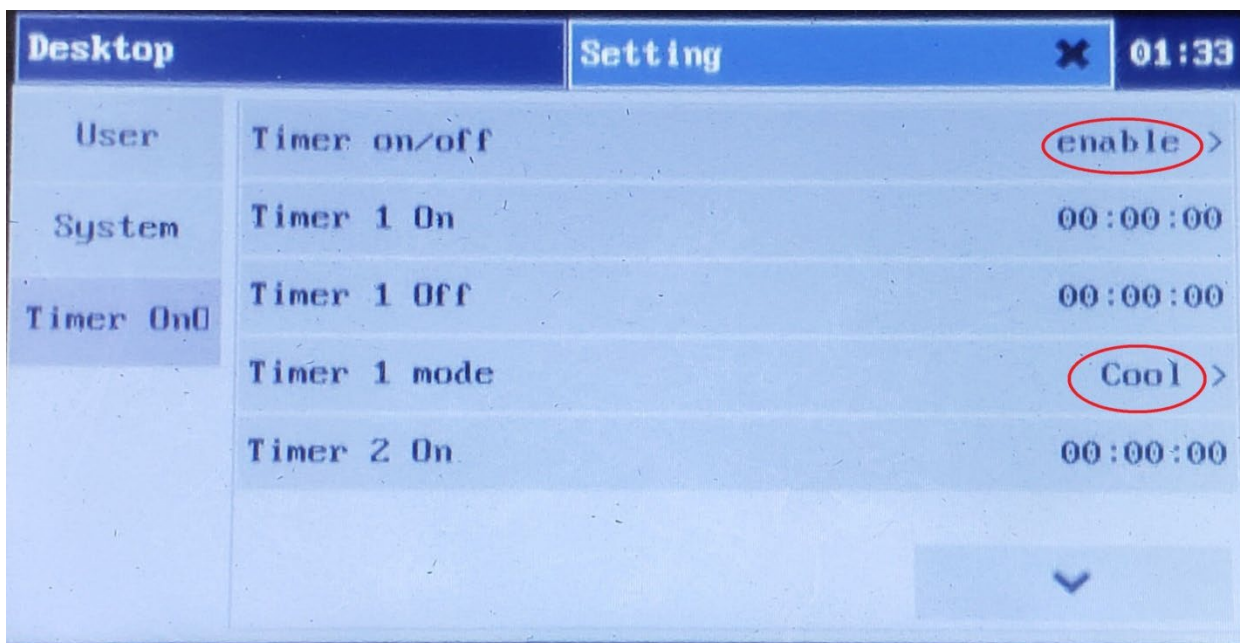

To use the timer functions the timer on/off must be enabled. There are 4 timers labeled timer 1-4 with a mode selection for each timer.

Standard Controller (cont'd)

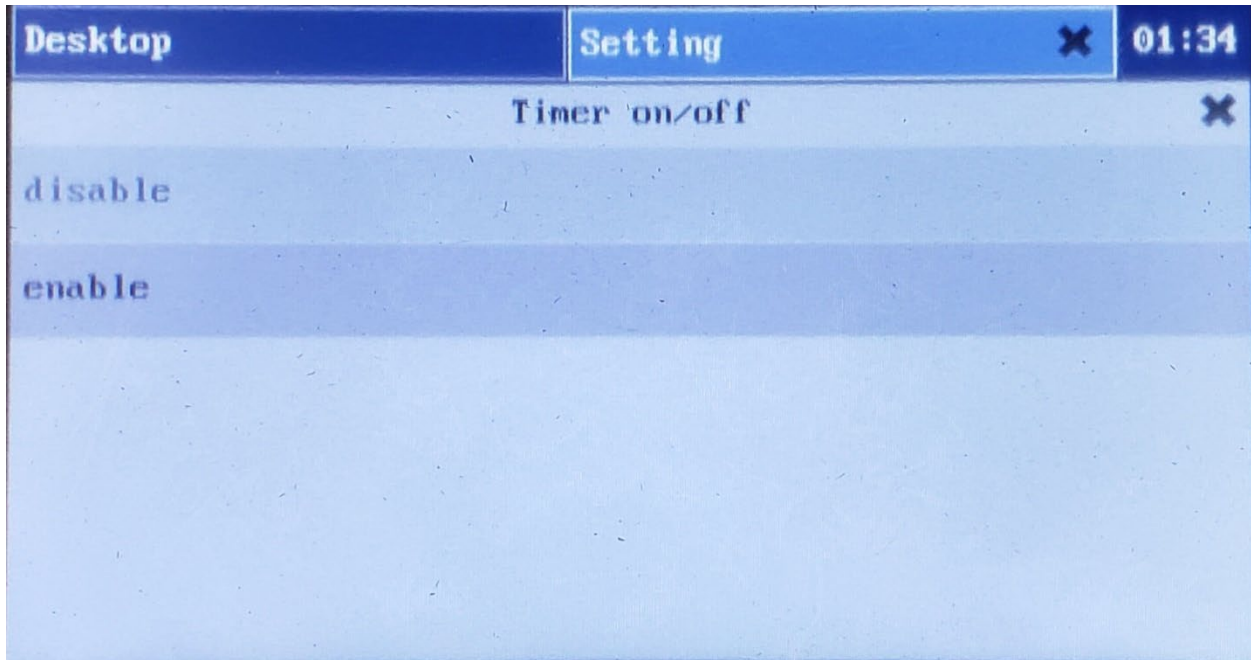

After enabling the timer function touch the X in the top right screen to return to the previous screen.

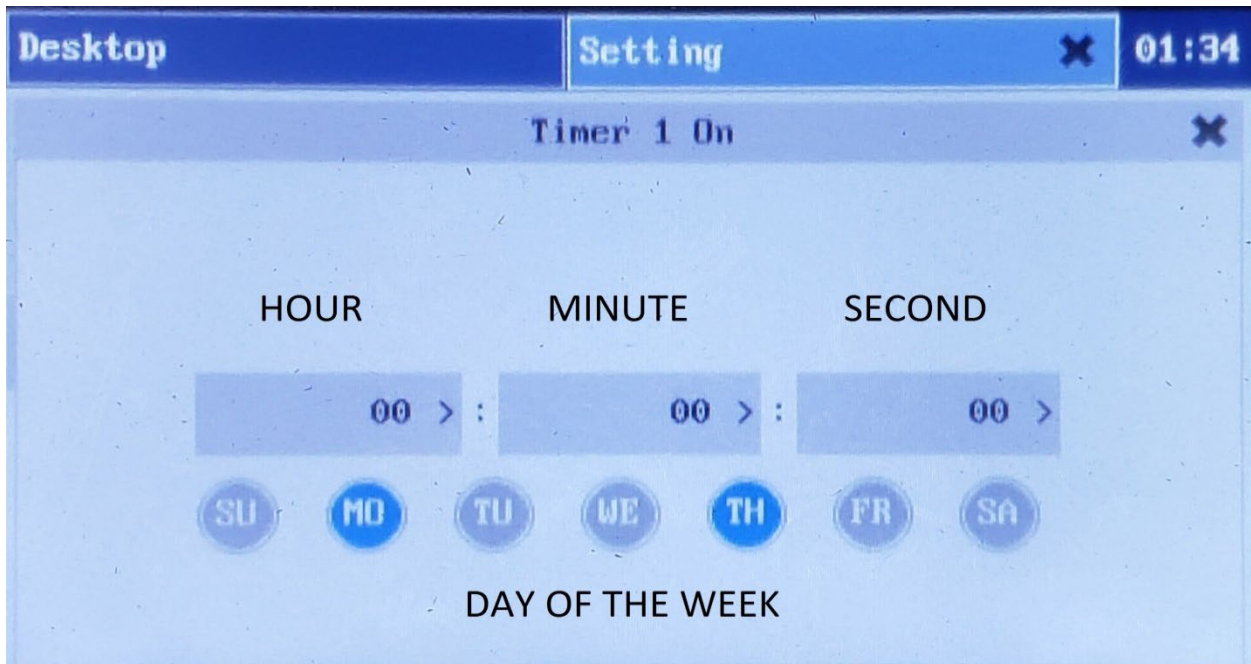

Standard Controller (cont'd)

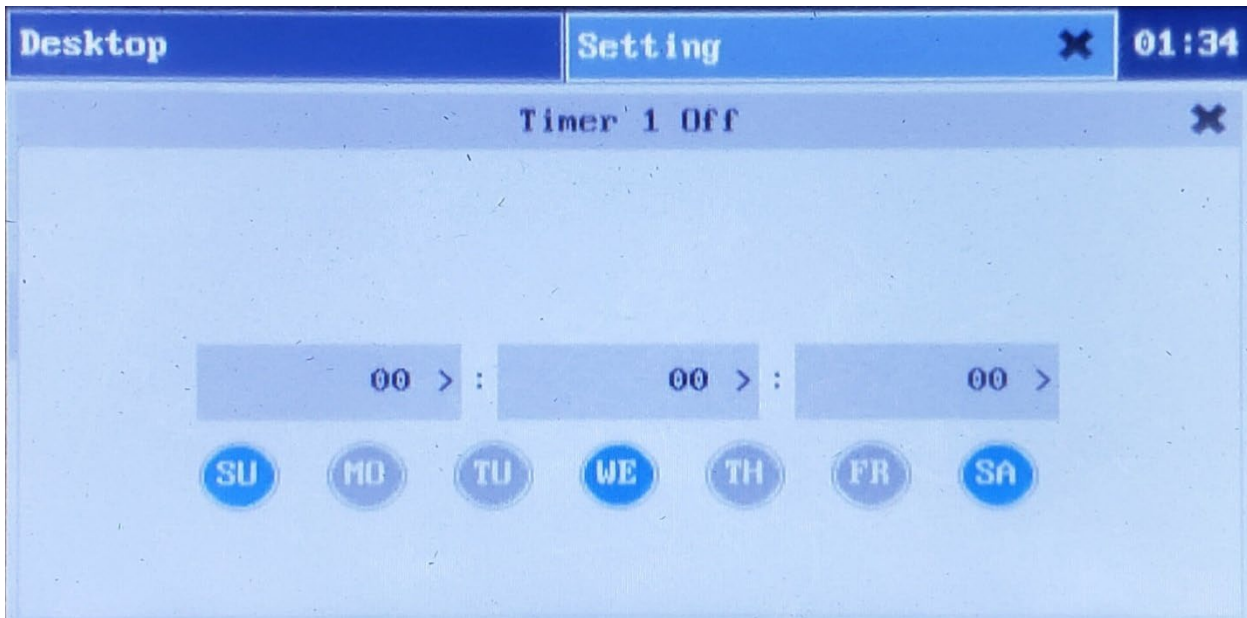

Touch the current time values to change the hour, minute and second. Touch the day of the week buttons to highlight them and make active.

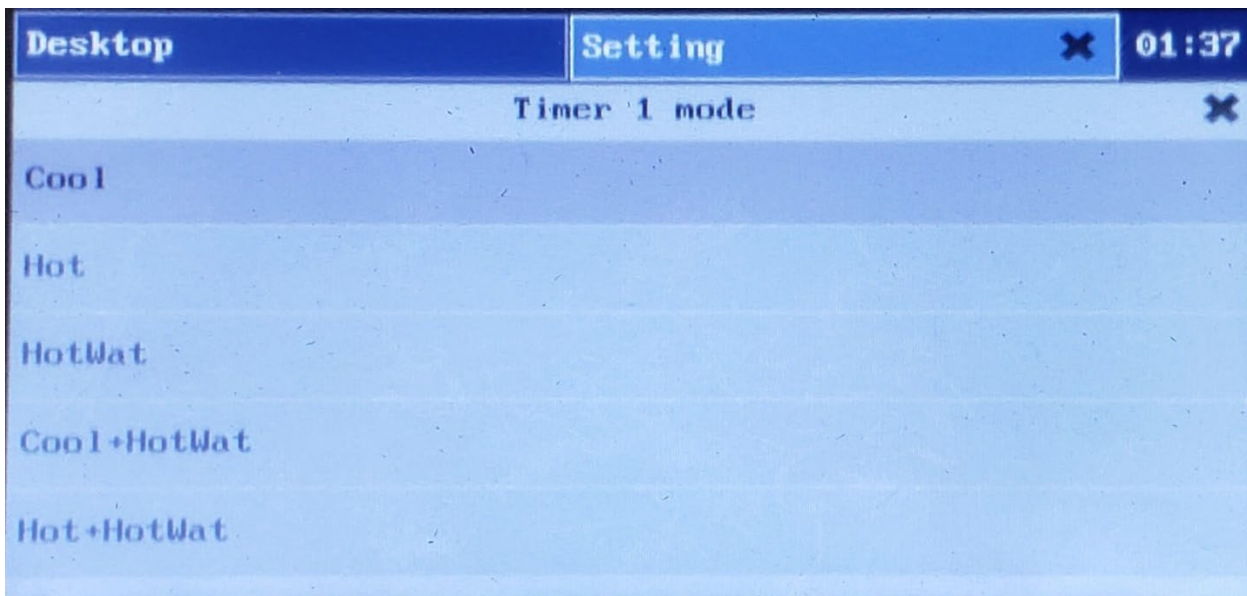

There are 5 modes that can be set to use electricity when the rate is lower. Only one mode can be set for each timer 1-4.

Standard Controller (cont'd)

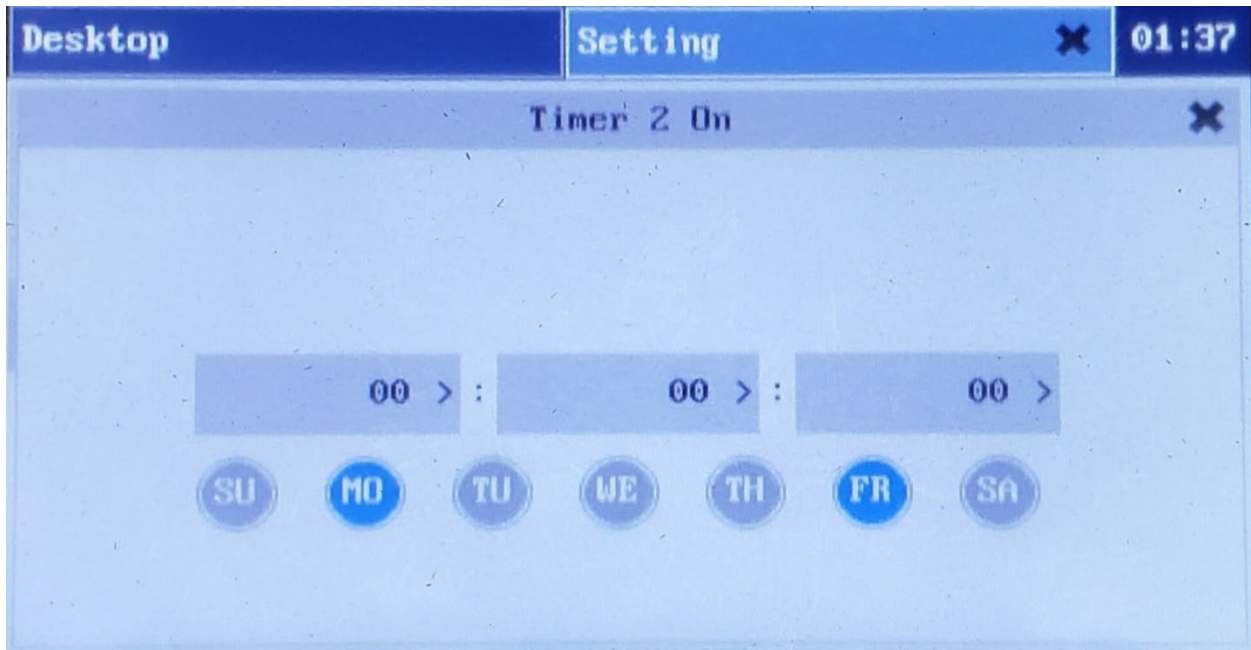

Program each timer the same way using the touch screen to set the values.

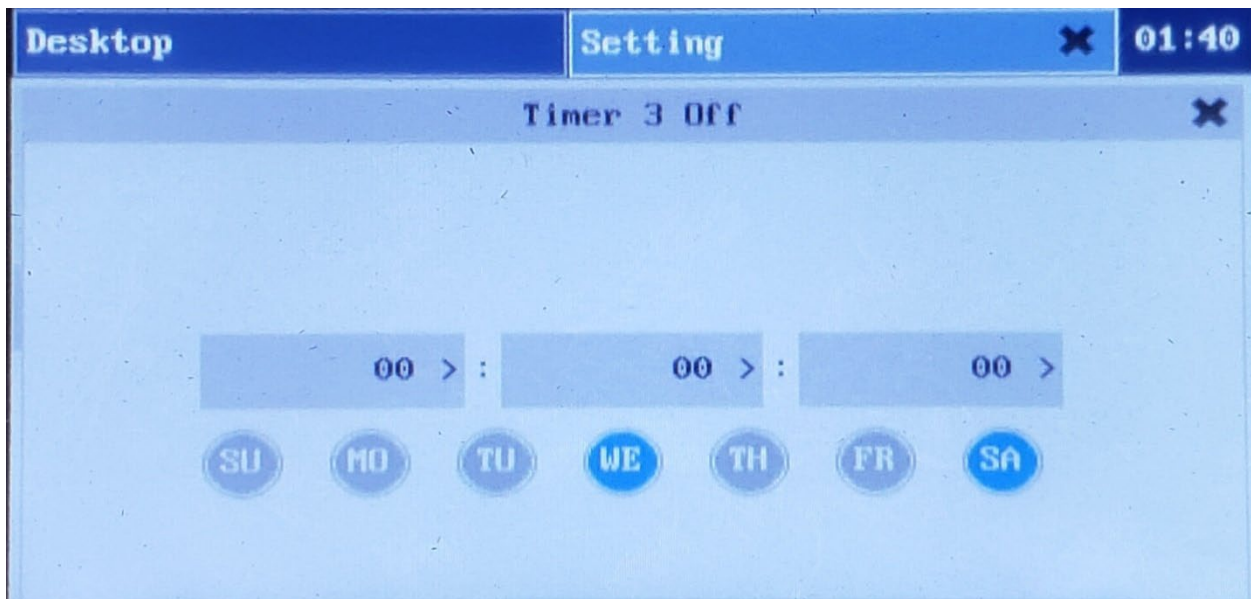

Timer 3 "OFF" settings.

Standard Controller (cont'd)

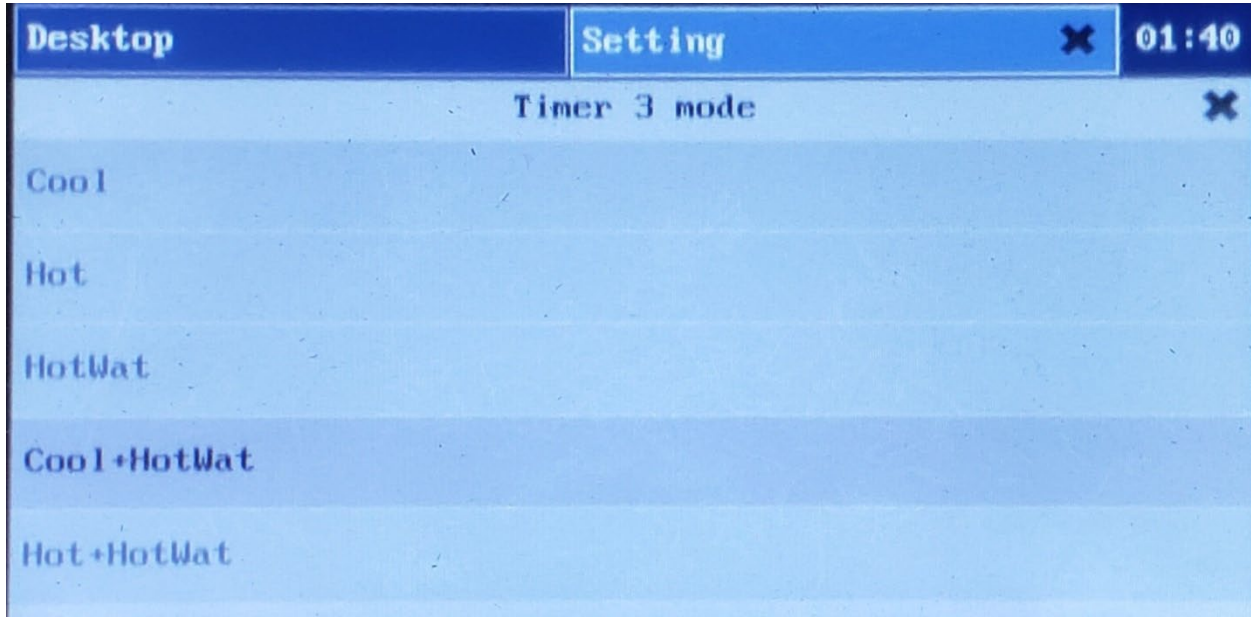

Timer 3 "Mode" settings.

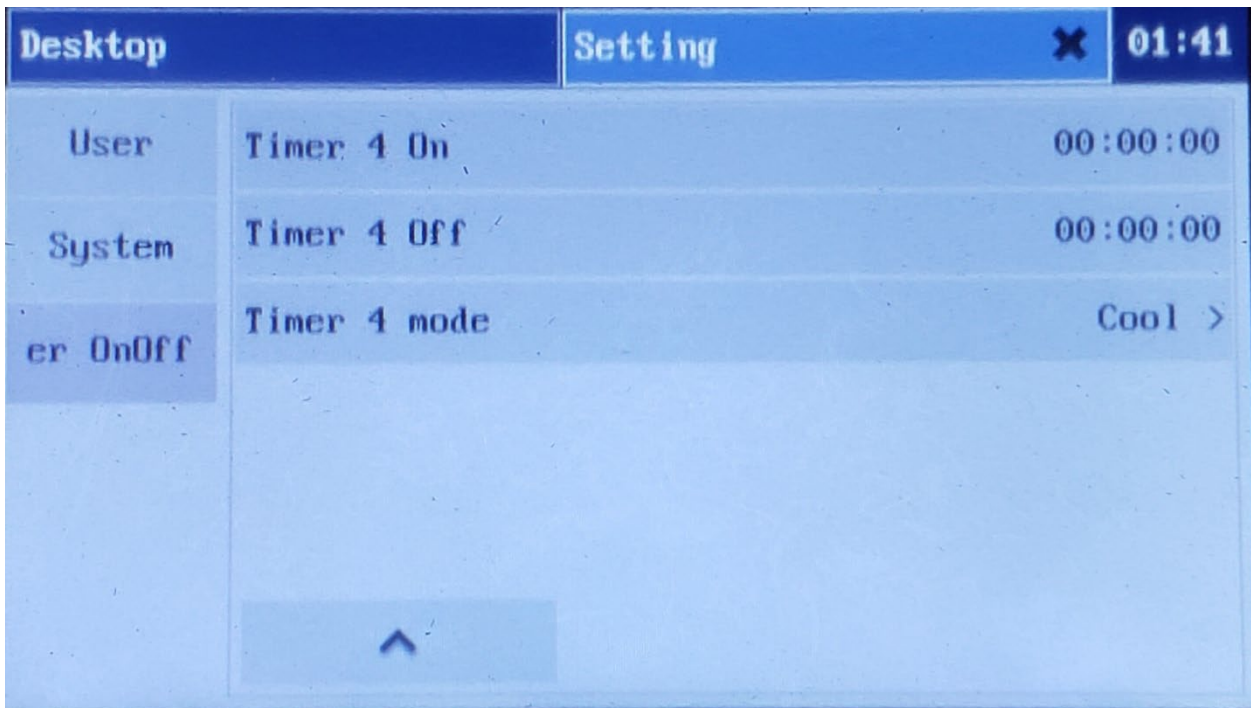

Timer 4 ON, OFF and MODE settings.

Standard Controller (cont'd)

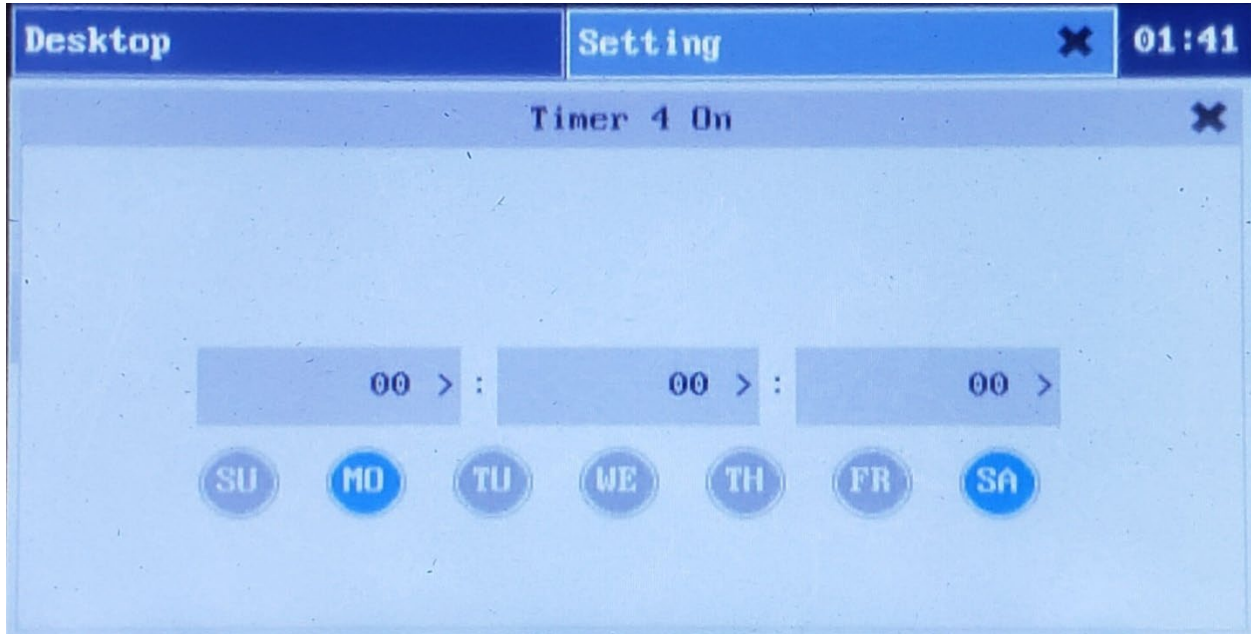

Timer 4 "ON" settings.

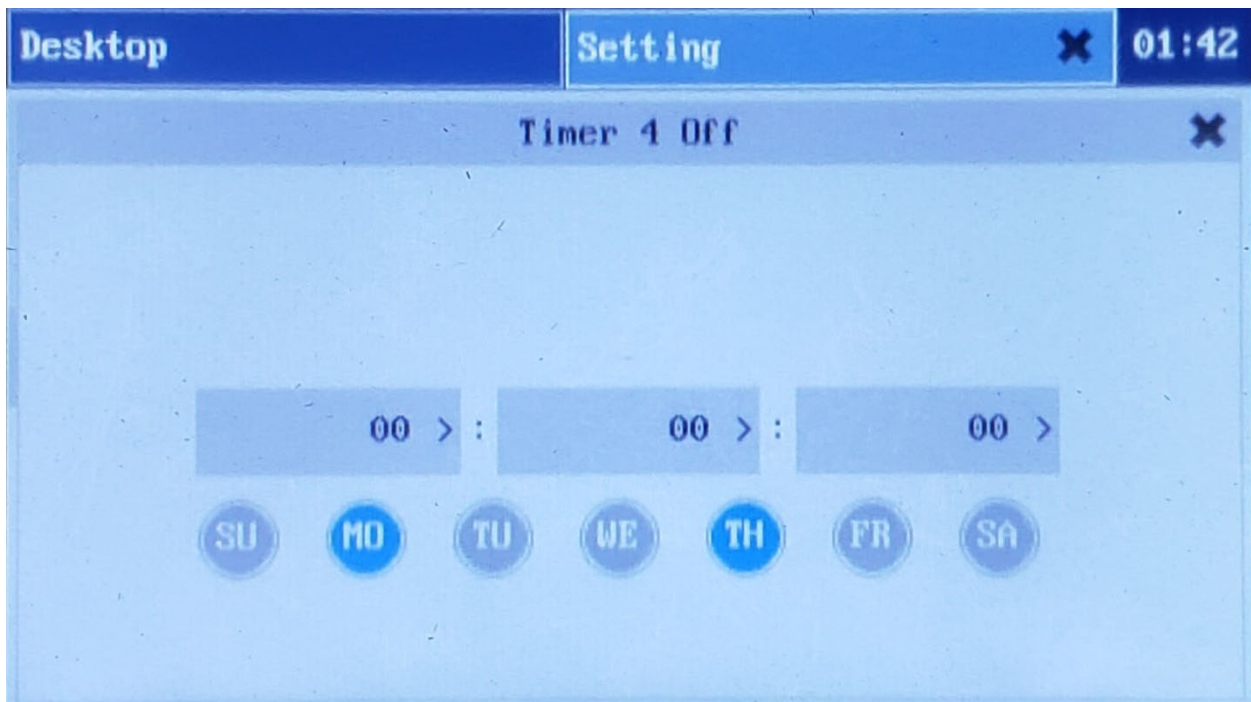

Timer 4 "OFF" settings.

Standard Controller (cont'd)

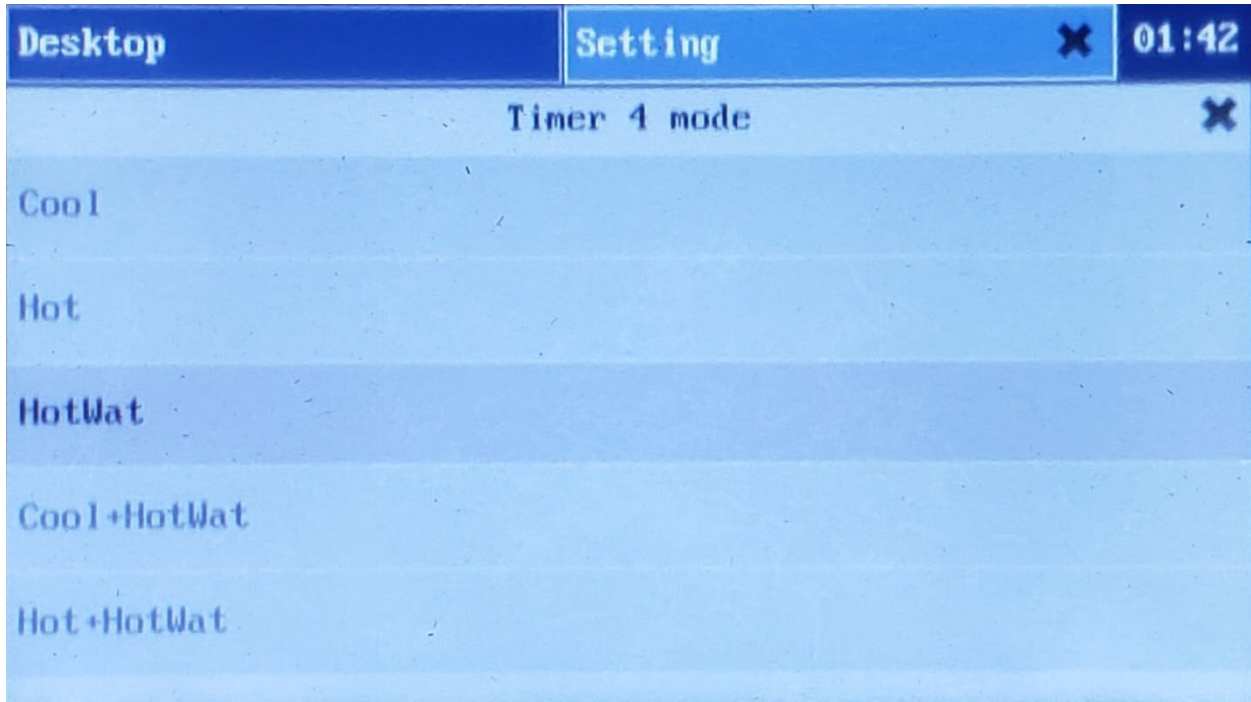

Timer 4 "Mode" settings

2 Operating the CX34

To select a mode to operate in, from the desktop, touch “settings”. The screen below will appear.

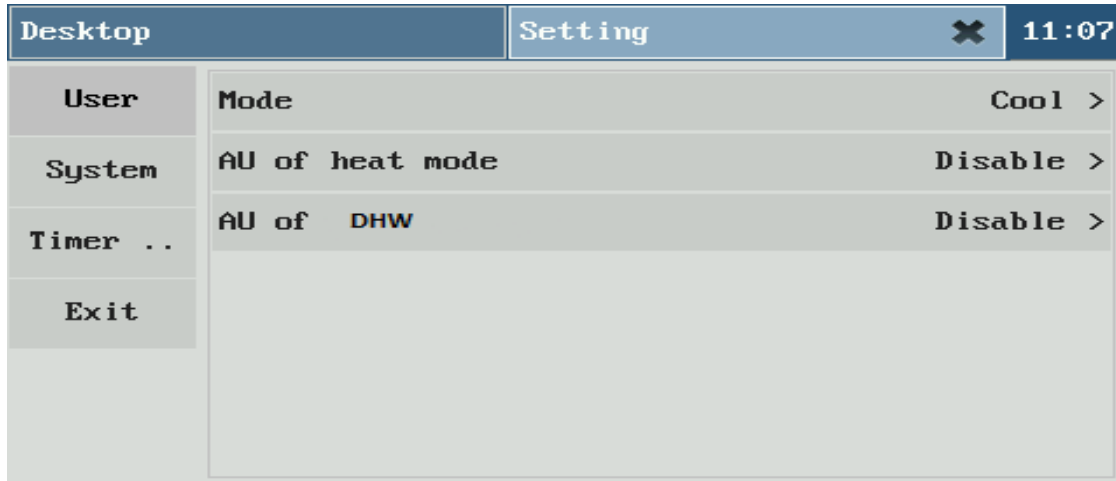

Touch the mode bar and the screen below will appear. Select the mode you want by touching the bar associated with the mode. AU Heat Mode should be disabled unless using Dynamic Outdoor Reset (p. 57) and AU DHW Mode is not used on the CX34 and should be disabled

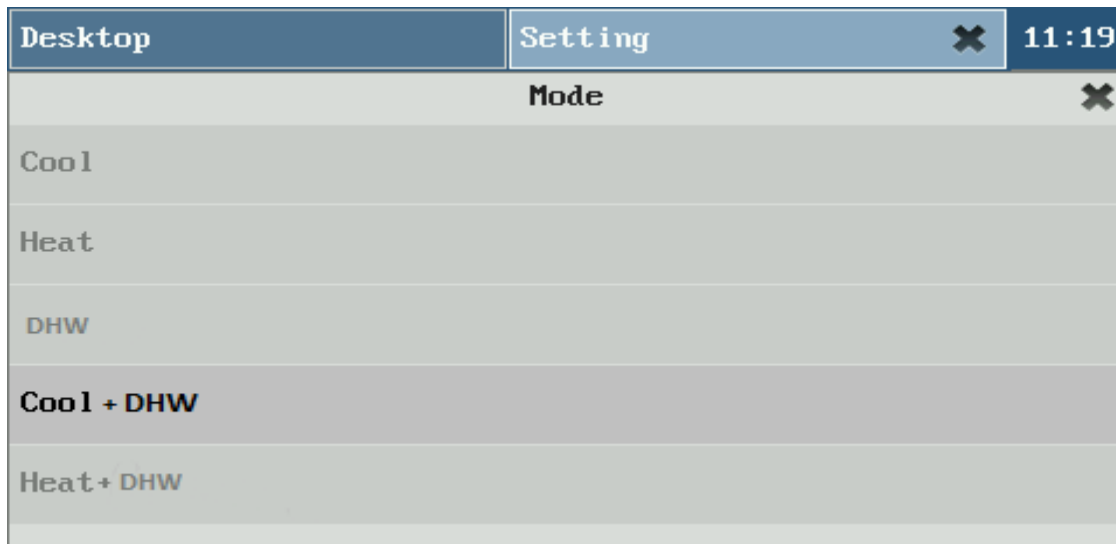

To **Start** the selected mode hit the Start button then “OK”

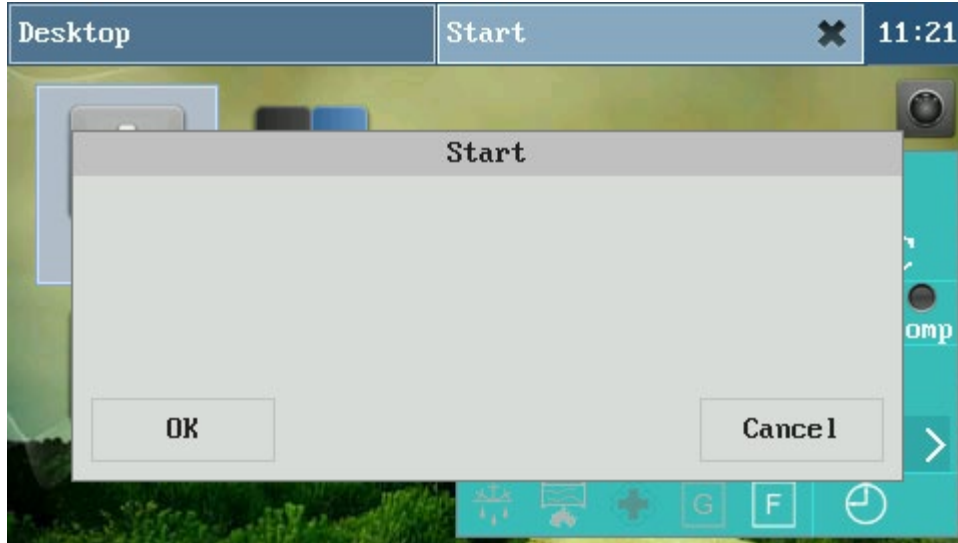

Use this same sequence for all of the modes. Always “shutdown” the chiller and wait for the compressor to turn off before removing the power

To shut down a mode, touch the “shutdown” icon.

Then touch “OK”.

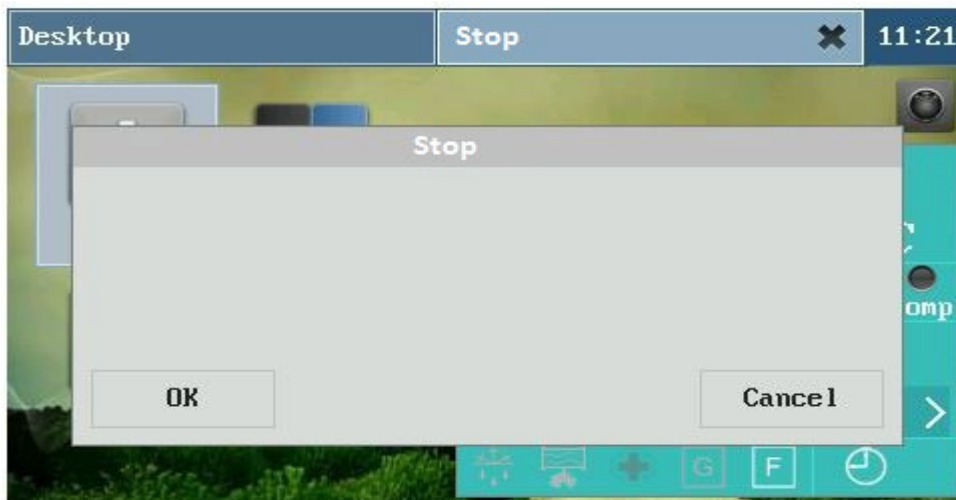
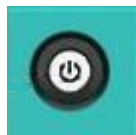



Setting the target or Set Point Temperature



Next, to set the temperature, go back to the desktop and touch the “set target AC” icon. Using the keypad select the desired temperature and touch the “ENT” icon.

Note* The AC Target must be set for both heating and cooling modes. The target temperature is the EWT (entering water temperature) (return temperature) and implies a LWT (leaving water temperature)(supply temperature) 9-10F higher. For example , for heating target if you want a supply temperature of 100F set the AC Target to 90F. For a cooling supply temp of 44F, the AC target would be 54F

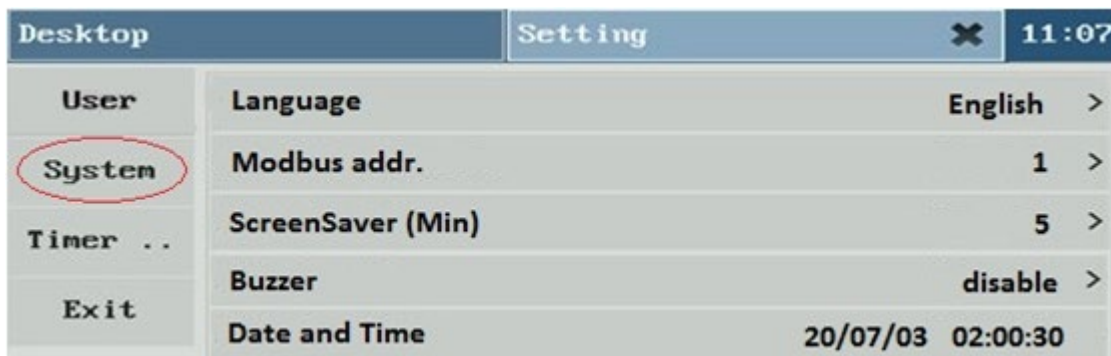

The Modbus address can be changed by touching “System”, then Modbus addr.

Manufacturers Settings (Parameter Checking and Setting) “P Parameters”

Touch and hold the lower left side of the main window for more than 3 seconds to enter the factory setting confirmation window as shown in Figure 3-1, press "Confirm" Factory setting, or press “Cancel” to exit.



“Press here” with finger turned sideways for 5 seconds.

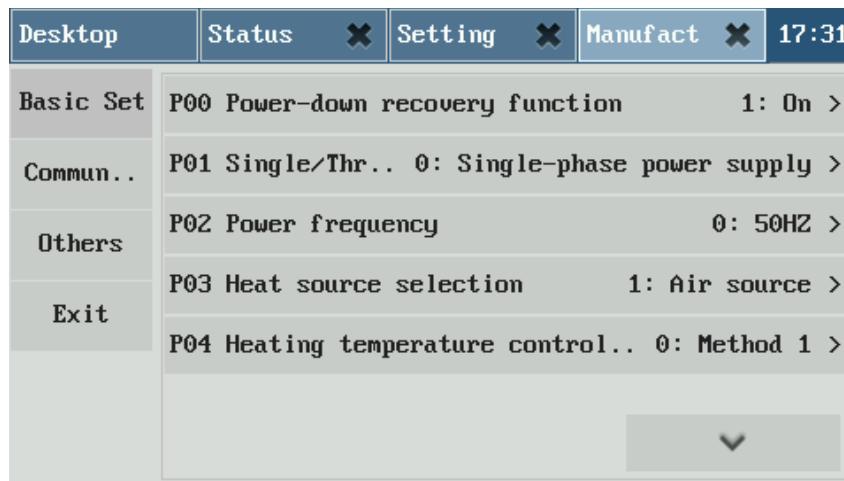
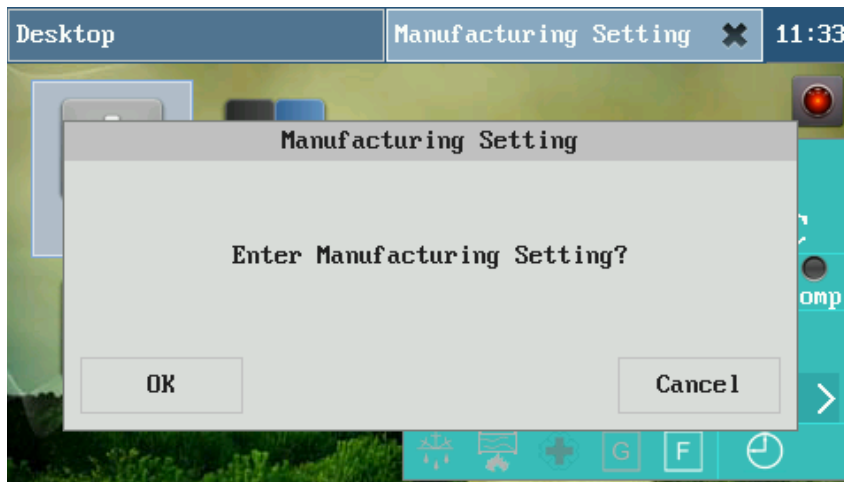

3.1 Communication Setting

Communication settings include settings for the protocol and baud rate. These settings should never be changed. Fig 3-3

Enter the factory settings menus as shown in figure 3-1, the left is the "main menu", on the right are the "P parameters". A complete list of P parameters starts on page 51. For Multi-pages, click on the "Down arrow" to display the next page.

Main menu includes:

- (1) Basic settings "P Parameters"
- (2) Communication settings
- (3) Others

3.2 OTHER FUNCTIONS

Initialize the control panel: The initialization of the control panel function is used to initialize all parameters in the control panel back to factory settings. Figure 3-4

Delete the fault history: Deletes all historical faults, do not delete, let them roll over.

Password setting: To set the password to enter settings mode, do not change.

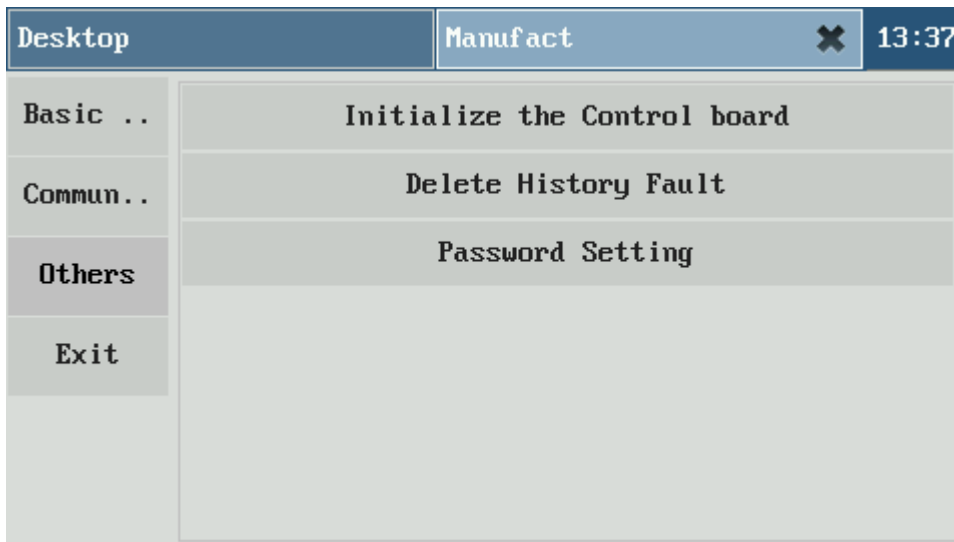
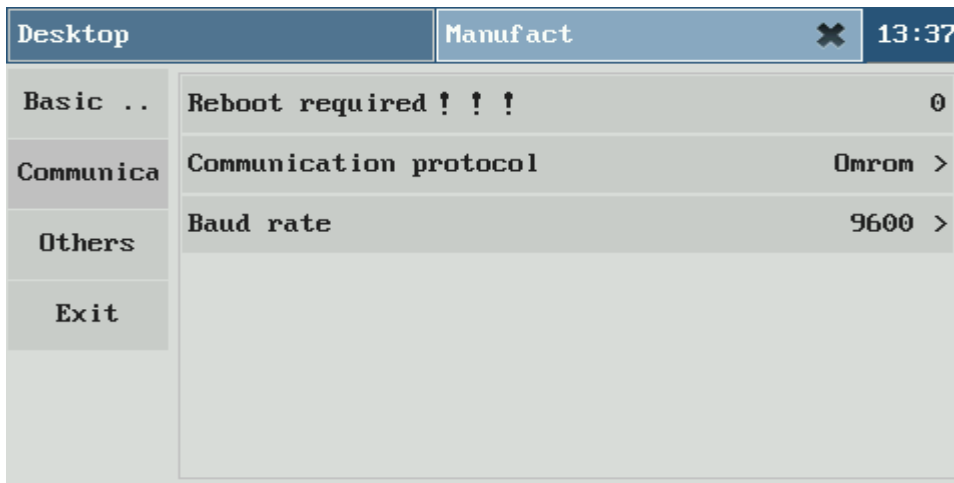

4. Parameter Checking and Setting “MFG MODE”

NOTE: Your controller will show some parameters that are not listed here, If they are not listed they are not applicable to the CX34. Please don't change them.

NOTE: These “P” Parameters are the manufacturers settings. Please don't make changes without instructions from Chiltrix technical support department. **THE CX34 MUST BE POWER-CYCLED AT THE BREAKER TO SAVE A CHANGE TO MFR. SETTINGS**

NO	Name	scope/means	Range, Meaning	Default
P00	Power-down recovery function	0: off; 1: on	0: off; 1: on	1
P01	Input Power: Single / three phase selection	0: Single-phase 1: Three-phase	0: Single-phase power Three-phase power	0
P02	Power frequency	0: 50HZ; 1: 60HZ	5: 50HZ; 1: 60HZ	1
P03	Heat source selection	0: ground source; 1: air source	0: ground source 1: Air source	1
P04	Heating temperature control method	0: Method 1; 1: Method 2	0: Method 1 : 1: Method 2	0
P05	Defrost method selection	0: Method 1; 1: Method 2	0: Method 1 : 1: Method 2	0
P06	FREECOOLING validation	0: valid; 1: invalid	0: valid; 1: invalid	1
P07	Frequency control method	0: Method 1; 1: Method 2	0: Method 1; 1: Method 2	0
P08	DHW validation G1	0: valid; 1: invalid	0: valid; 1: invalid	1
P09	Air conditioning and heating validation	0: valid; 1: invalid	0: valid; 1: invalid	0
P10	Air conditioning and Cooling validation	0: valid; 1: invalid	0: valid; 1: invalid	0
P11	DHW hot water temp hysteresis	2~15°C, minus hysteresis	2~15°C, minus hysteresis	2°C
P12	AC temp hysteresis	2~15°C, minus hysteresis	2~15°C, minus hysteresis	2°C
P30	fan motor Category	0=AC fan, 1=EC fan1, 2=EC fan 2	0=AC Fan, 1=EC Fan1, 2= EC	1
P31	Maximum speed of the fan	10-100 (100 show1 00%)	1-10 (10=100%)	100
P32	Heating fan speed control temperature difference	2~15°C	2~15°C	6°C
P33	Cooling Fan speed control Temperature difference	5~18°C	5~18°C	12°C
P34	Defrost method	0: Method 1;	0: Method 1;	0
P35	defrost starting temp	-5~5°C	C00 Pipe sensor	-1°C
P36	defrost interval time multiple rate	0: Not defrost; 1; 2; 3; 4: (interval X 4)	0: Not defrost; 1; 2; 3; 4: (interval X 4)	1
P37	The first defrost interval	15~99minu (1st interval after repower on)	15~99minute (1st interval after repower on)	35
P38	defrost exit temp	10~35°C	C00 Pipe sensor	30°C
P45	Allowed defrost coil temperature	-20~5°C	Defrost method 1 Condition 2	-6°C

NOTE: Your controller will show some parameters that are not listed here, If they are not listed they are not applicable to the CX34. Please don't change them.

P47	hot water frequency limitation	2~10, max frequency 20~100%	2~10= max frequency 20~100%	10
P48	AC heating AU mode highest temp	Note this is return temp (5C ΔT)	30~44°C	45°C
P49	AC Heating AU mode offset temperature	-10~10°C	-10~10°C	0°C
P50	solenoid valve function parameters	0=G3 seasonal valve, 1=G3 solar valve	0= G3 is seasonal valve, 1=G3 is solar valve	0
P51	C4 Water pump type selection	0=AC Water pump, 1=EC Water pump	0=AC Water pump, 1=EC Water pump	1
P52	water pump working mode	0=Not stop, 1=stop after reaching target temp) 2=start 1 minute after each stopping of 15 minutes)	0=Not stop, 1=stop after reaching target temp, 2=start 1 minute after each stopping of 15 minutes)	0
P53	EC Water pump C4 Minimum speed	40-80%	40-80% 40,	40
P54	C5 Water pump type selection	0=AC Water pump, 1=EC Water pump	0=AC Water pump, 1=EC Water pump	0
P55	DHW e-heater activated ambient temp E1	-20~20°C	-20~20°C	0°C
P56	Electric heating function	0=electric heating, 1=the second heat source	0=electric heating, 1=the second heat source	0
P57	AC e-heater activated ambient temp E2	-20~20°C	-20~20°C	0°C
P58	2nd heat source starting air temp	-30~15°C	-30~15°C	-15°C
P59	AC anti-freezing temperature	-15~5°C	-15~5°C	3°C
P60	Virus killing interval days	7~99day	7~99 day	99
P61	Start virus killing time	1~24hour	1~24 hour	1
P62	Virus killing holding time	5~99minu	5~99 Min	5
P63	Target temperature of virus killing	55~80°C	55~80°C	55°C
P64	AC water flow switch type selection	0=Water flow switch 1=flow meter 2=DN25 sensor 3: Brass flow sensor	0=Water flow switch 1= flow meter 2=DN25 sensor 3: Brass flow sensor	3
P65	AC minimum water flow (Sets P5)	9-80L/m	9-80L/m	8
P68	air source heat pump FREECOOLING function start ambient temp	-16~20°C	-16~20°C	5°C
P69	FREECOOLING function additional Temperature difference to start full free cooling. (compressor stops)	3~15°C	3~15°C	5°C
P71	Cooling Maximum set temperature	Note this is return temp (5C ΔT)	12~35°C	12°C
P72	Heating maximum set temperature	Note this is return temp (5C ΔT)	25~44°C	35°C
P73	DHW The highest set temperature	Tank setting	25~55°C	55°C

NOTE: These “P” Parameters are the manufacturers settings. Please don't make changes without instructions from Chiltrix technical support department. THE CX34 MUST BE POWER-CYCLED AT THE BREAKER TO SAVE A CHANGE TO MFR. SETTINGS

NOTE: These “P” Parameters are the manufacturers settings. Please don’t make changes without instructions from Chiltrix technical support department. **THE CX34 MUST BE POWER-CYCLED AT THE BREAKER TO SAVE A CHANGE TO MFR. SETTINGS**

P74	Debugging fixed operating frequency	10~100 HZ	10~100 HZ	50HZ
P75	run setting frequency	0= Manual frequency, 1= Auto frequency	00= Manual frequency, 1= Auto frequency	1
P76	EEV manually open degree (heating)	70~480	70~480	200
P77	EEV manually open degree (cooling)	70~480	70~480	250
P78	EEV control mode	0=No,1=table list,2=manually, 3=automatically	0=No,1=table list,2=manually, 3=automatically	3
P79	target overheat degree (heating)	-5~10°C	-5~10°C	-1°C
P80	target overheat degree (cooling)	-5~10°C	-5~10°C	2°C
P81	night mode validation	0= no start, 1= start	0= no start, 1= start	0
P82	night mode starting point	0-23 (for relative time)	0-23 (for relative time)	22
P83	night mode ending point	0-23 (for relative time)	0-23 (for relative time)	6
P88	Model selection	0~255	0~255	4
P94	Whether to use high and low pressure transmitter	0=Disabled 1= Enable	0= N/A 1= Enable	0
P95	C4 Control the temperature difference (°C)	2~8	2~8	5
P96	Compressor Manufacturer		Mitsubishi	
P97	Forced sterilization	0,normal; 1,forced;(Automatically reset to 0 after one execution)	Normal	0
P98	System parameter recovery	0 normal; 1 Recovery (automatically reset to 0 after one execution)	Normal	0
P99	Compressor manufacturer 2			101
P100	Virus Killing Function validation	P100=0 Invalid; 1 valid	Invalid =0	0
P101	EVV Max Open Degree	300-500 default:430		430
P102	Defrosting EEV Open Degree			350
P103	AC Electric Heater Power Watts	0-99999w default:5000		5000
P104	Temperature Unit	Centigrade =0	Fahrenheit =1	1
P105	Heat recovery function validation	0:Invalid; 1:valid		
P106	AC rated voltage	0-500V		220
P107	AC heat transfer coefficient	100-600WF		500
P108	AC Voltage compensation			0
P109	Cooling Inlet Target temp range	P109=0:10~25C. P109=1:5~25C (Must use glycol, not frozen at -10C).		
P110	AC heating minimum frequency	30~50hz		30hz

5 STATUS

The status application is used to check the detailed status of the unit operation, such as compressor speed, fan speed, G1, G2, G3, G4 valves and so on. See Fig. 5-1

5.1 State preview display interface

- a) **Compressor:** Displays the current working status of the compressor.
- b) **Compressor Heating:** Displays compressor heating status.
- c) **Outdoor fan:** show the working status of the outdoor fan.
- d) **Reversing valve, electronic expansion valve, electrical heating, G1 valve** and other work status, query can be directly observed through this interface.

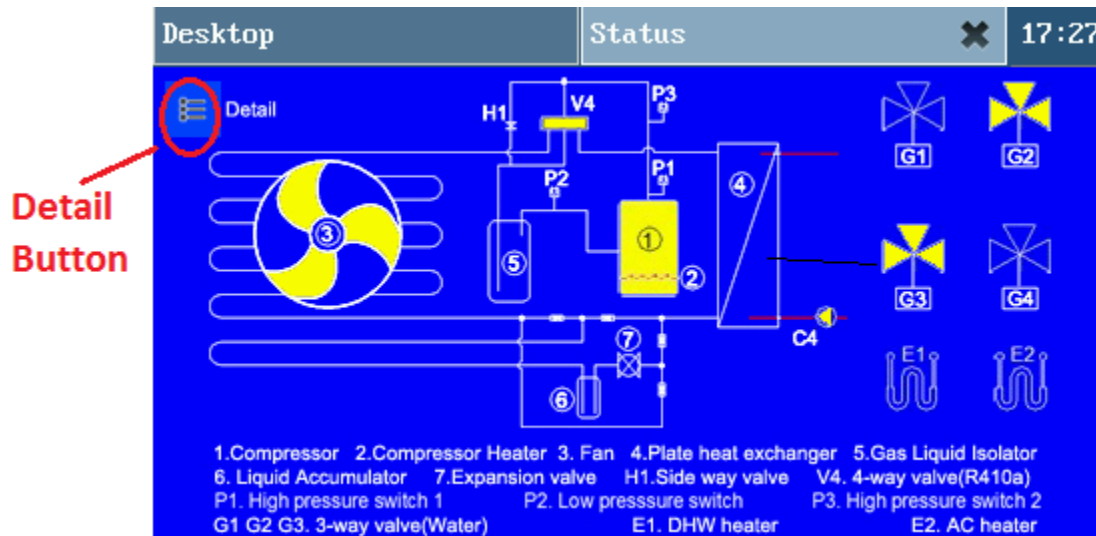

Figure 5-1

5.2 Detailed Status Interface “C Parameters”

Click "detail" in the status query interface to enter the detailed status interface of the machine, as shown in Figure 5-1. Click the arrow “->” button to return to the previous state interface..

item	value
C08 Water source outlet water temp	25.0°C
C09 Compressor current value	0.0A
C10 High pressure value	0.0MPa
C11 Low pressure value	0.0MPa
C12 Water Source side water flow volume	0.0L/m
C13 Usage side water flow volume	0.0L/m
C14 Functional parameter(P03)	1:Air source Source
C15 Functional para..	0:AC heating temp control method 1

Figure 5-2

6. Parameter Checking Only

NOTE: Your controller will show some parameters that are not listed here, If they are not listed they are not applicable to the CX34

No	Name	Scope/means	Range, Meaning
C00	out pipe temp	-30~97°C	-30~97°C
C01	compressor discharge temp	-30~128°C	-30~128°C
C02	ambient temp	-30~97°C	-30~97°C
C03	Suction temperature	-30~97°C	-30~97°C
C04	Plate heat exchanger temp	-30~97°C	-30~97°C
C05	AC outlet water temp	-30~97°C	-30~97°C
C06	Solar temperature	-30~97°C	-30~97°C
C09	Compressor current value P15	0.0~30.0A	0.00~30.00A
C13	Usage side water flow volume	0~100L/m Actual Flow	0~100L/m
C14	P03 Status	0=Air source, 1= Ground source	0=Air source, 1=Ground source
C15	P04 Status	0=Heating temperature control mode one, 1= Heating temperature control mode two	AC heating temp control method
C16	P05 Status	0=Defrost mode one, 1= Defrost mode two	Defrost method
C17	P06 Status	0= Free cooling valid, 1= Free cooling invalid	Free cooling=0 valid, 1=invalid
C18	P07 Status	0=Frequency mode one, 1= Frequency mode two	Frequency method
C19	P08 Status	0= DHW valid, 1= DHW invalid	0=DHW valid, 1= DHW invalid
C20	P09 Status	0=Heating valid, 1= Heating invalid	AC heating valid= 0 valid 1= invalid
C21	P10 Status	0=cooling valid, 1=cooling invalid	0=cooling valid, 1=cooling invalid
C22	high pressure switch status	1= on, 0= off	1= on, 0= off
C23	low pressure switch status	1=on, 0= off	1=on, 0= off
C24	second high pressure switch status	1=on, 0= off	1=on, 0= off
C25	inner water flow switch	1=on, 0= off	1=on, 0= off
C27	Compressor Frequency	Displays the actual operating frequency	Show actual frequency

NOTE: Your controller will show some parameters that are not listed here, If they are not listed they are not applicable to the CX34

C28	Thermal switch status	1=on, 0= off	1=on, 0= off
C29	outdoor fan motor	1= run, 0= stop	1=on, 0= off
C30	electrical valve 1	1= run, 0= stop	1= run, 0= stop
C31	electrical valve 2	1= run, 0= stop	1= run, 0= stop
C32	electrical valve 3	1= run, 0= stop	1= run, 0= stop
C33	electrical valve 4	1= run, 0= stop	1= run, 0= stop
C34	C4water pump	1= run, 0= stop	1= run, 0= stop
C35	C5water pump	1= run, 0= stop	1= run, 0= stop
C36	C6water pump	1= run, 0= stop	1= run, 0= stop
C37	The accumulative days after last virus killing	0-99 (From the last complete sterilization to the present, cumulative number of days)	0-99 (from the last complete sterilization to the present, cumulative number of days)
C38	outdoor modular temp	-30~97°C	-30~97°C
C39	Expansion valve 1 opening degree	0~500	0~500
C40	Expansion valve 2 opening degree	0~500	0~500
C41	inner pipe temp display	-30~97°C	-30~97°C
C42	Heating Method 2 target temperature	-30~97°C	-30~97°C
C43	Indoor temperature control switch	1=on, 0= off	1=on, 0= off
C44	fan type	0= AC fan, 1= EC fan 1, 2= EC fan 2	0= AC fan, 1= EC fan 1, 2= EC fan 2
C45	EC fan motor 1 speed	0~3000	0~3000
C46	EC fan motor 2 speed	0~3000	0~3000
C47	water pump types	0= AC Water pump 1= EC Water pump	0= AC Water pump 1= EC Water pump
C48	water pump1 speed (C4)	1~10 (10 Show 100%)	1~10 (10 means 100%)
C49	water pump2 speed	1~10 (10 Show 100%)	1~10 (10 means 100%)
C50	Inductor AC Current value P15	0~50A	0~50A
C51	Driver working status value	Hexadecimal value	Hexadecimal values
C52	Compressor shut down Code	Hexadecimal value	Hexadecimal values
C53	Driver allowed highest frequency	30-120Hz	30-120Hz
C54	Reduce frequency temperature setting	55~200°C	55~200°C
C55	input AC Voltage value	0~550V	0~550V
C56	input AC current value	0~50A (IPM test)	0~50A (IPM Check)
C57	Compressor phase current value	0~50A (IPM test)	0~50A (IPM Check)
C58	Bus line voltage	0~750V	0~750V
C59	Fan shutdown Code	Hexadecimal value	Hexadecimal values
C60	IPM temp	55~200°C	55~200°C
C61	Compressor total running time Will reset after power cycle	0~65000	0~65000 hour

7 ABOUT

The interface displays the touch screen and PLC version information, as shown in Figure 7-1.

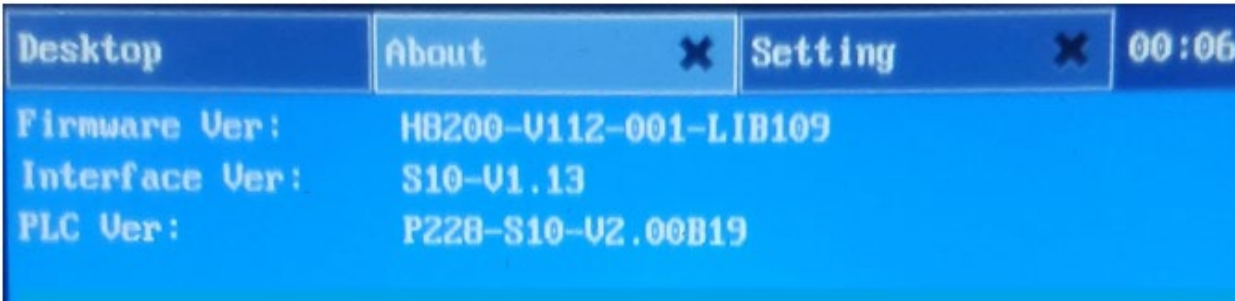

Figure 7-1

8 INITIAL TEMPERATURE SETTINGS

*Note – All set points refer to the CX34 return (inlet) temperature, and implies a leaving (outlet) temperature of ~10°F cooler(cooling)/warmer(heating) than what you set.

For example if you want heating output to be ~100°F you would set the heating target to 90°F. Default setting for cooling should be 54°F, therefore the leaving (outlet) temperature would be around 44°F.

Standard settings would be as follows: Heating, set at 30°C (86°F) return for radiant (for ~supply temp of 95F) , or 35°C (95°F) return for fan coils or fan coils + radiant (for ~ supply temp of 105F).

For cooling mode the standard setting would be 12°C (54°F) to get ~44°F outlet temperature.

Detailed settings as follows:

NO.	Meaning	Selected temperature range	Recommended controller temperature initial setting
1	Cooling returned water temp (10F/5C ΔT)	50°F ~ 77°F	54°F(12C)
2	Heating returned water temp (10F/5C ΔT)	44°C ~ 111°F	95°F Fan coils(35C) 85°F for radiant(30C)
3	DHW temp	50°F ~ 122°F	122°F (50C) MAKE SURE TO READ THE CHILTRIX TANK MANUAL BEFORE ENABLING DHW

NOTE:

The lower the heating setting used, the higher the system COP. The higher the cooling setting used, the higher the EER. **DO NOT SET HEATING AC TARGET >45C/112F**

Error Codes / Faults

9 FAULTS

Touch the **ERROR** icon to access the current error.

Fault application is used to query the current or historical fault. After entering the fault application, click on the main window of the "current fault" or "historical failure" to display errors.

9.1 CURRENT FAULT

To enter the current fault display as shown in Figure 8-1, the left side shows the fault item, the format is "fault number". On the right side of the three buttons are "on a page", "next" page, "reset", click the reset button to reset the current fault.

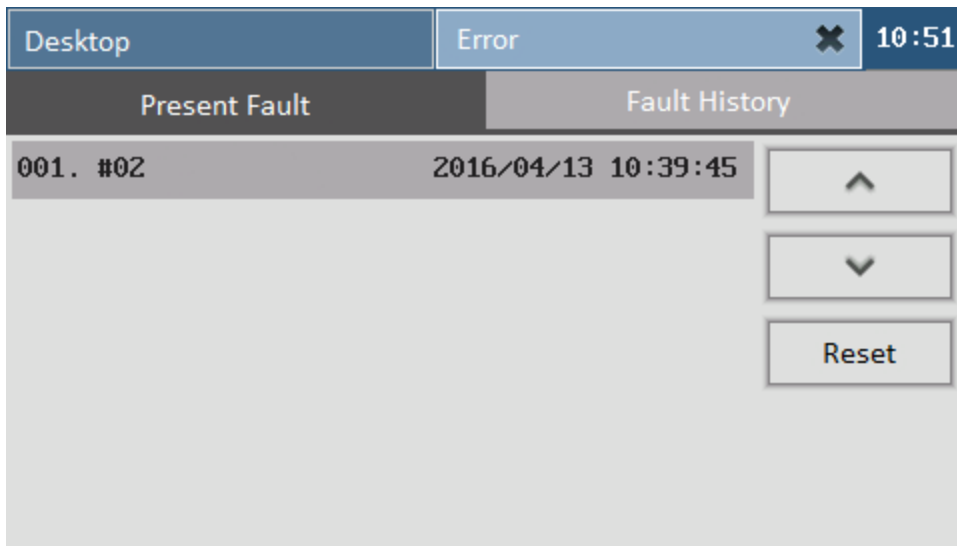

Figure 9-1

9.2 FAULT HISTORY

Enter the history fault display as shown in Figure 9-2, the left side is the fault item, the right side has the previous page, the next page and the query time of the fault history. The query time can be set by clicking the year / month / day.

9.3 CX34 Error Codes, Error Meaning, and Reason

Error code	Error Meaning	Reason
E1	Compressor discharge high temp protection	Poor refrigerant or throttle is not normal (stop compressor)
E2	Outdoor air temp sensor error	Outdoor air temp sensor open or short circuit (stop compressor)
E3	Outer coil pipe temp sensor error	Outdoor coil pipe temp sensor open or short circuit (stop compressor)
E4	Pipe returned gas sensor error	Outdoor coil pipe temp sensor open or short circuit (stop compressor)
E5	indoor refrigerant pipe temp sensor error	Indoor pipe temp sensor open or short circuit (stop compressor)
E6	Coil high temp protection	Outdoor coil pipe temp over 60°C (stop compressor)
E7	solar water temp sensor error	solar temp sensor open or short circuit (stop compressor)
E8	AC inlet water temp sensor error	AC return water temp sensor open or short circuit (stop compressor)
E9	AC outlet water temp sensor error	AC outlet water temp sensor open or short circuit (stop compressor)
E10	DHW temp sensor error	DHW temp sensor open or short circuit (stop compressor)
E11	Indoor ambient sensor error	Indoor ambient sensor open or short circuit (stop compressor)
E12	water source inlet water temp sensor error	water source inlet temp sensor open or short circuit
E13	water source outlet temp sensor	water source outlet temp sensor open or short circuit
E14	system anti-freeze twice	(stop compressor)
E15	DHW anti-freeze twice	(stop compressor)
E16	discharge Probe error	Poor outdoor unit heat transfer
E17	System 2 antifreeze twice	(stop compressor)
P1	high pressure protection	(1) too much refrigerant; (2) throttle mechanism failure; (3) high voltage switch failure

P2	low pressure protection	(1) less refrigerant; (2) throttle failure; (3) low-voltage switch failure
P3	compressor overheat protection	(1) less refrigerant; (2) throttle mechanism failure
P4	over current protection Verify that P88 = 4	(1) too much refrigerant; (2) throttle mechanism failure; (3) current sensor failure
P5	indoor unit water flow error	(1) water flow is too small; (2) water switch failure
P6	outdoor water flow error	(1) water flow side is too small; (2) water source side of the water flow switch failure
P7	miss phase	Power failure
P8	wrong phase	Power failure
P9	communication error	The communication line is broken or the control board is damaged
P10	water source anti-freeze	(1) the water source side of the heat transfer or water temperature is too low; (2) water side of the water flow is insufficient
P11	water source water flow not enough	(1) water side of the water flow is low
P12	EPPRON initializes the fault	
P13	Control board and inverter communication fault	(1) The inverter and the circuit board communication line is loose (2) inverter fault
P14	The temperature difference between inlet and outlet is too large	(1) water flow is too small; (2) water switch failure
P15	Current limit frequency fault	Caused by current limitation at lubricant oil return operation. Set P33=6°C
F1	voltage protection	Power voltage is too high or too low, the voltage is normal after the machine to resume operation (motherboard detection)
F2	IPM Fault	IPM module is damaged
F3	Compressor Drive Fault	The compressor cannot start normally
F4	Compressor over current protection 1	IPM detects that the compressor current is excessive (IPM or compressor or wiring is faulty)
F5	Compressor over current protection 2	The motherboard detects that the compressor current is excessive
F6	IPM Overheat	IPM temperature exceeds the set value
F7	PFC Fault	PFC damage
F8	DC bus over voltage	DC voltage exceeds 410V
F9	DC bus under voltage	DC voltage less than 200V
F10	AC input over or under voltage	Power voltage is too high or too low, the voltage is normal after the machine to resume operation (IPM detection) (175V ~ 255V)
F11	AC input overcurrent	IPM detected AC current exceeded
F12	Temperature sensor Fault	temp sensor is open or shorted
F13	DSP and motherboard communication Fault	Communication break or control board failure
F14	EC fan failure 1	EC fan 1 not connected or fan failure
F15	EC fan failure 2	EC fan 2 not connected or fan failure

Dynamic Outdoor Reset Control

The Chiltrix controller is equipped with an automatic outdoor reset function.

Advantages & Misconceptions of Using Outdoor Reset

Most people in the radiant heating industry will tell you that outdoor reset is used to get more BTU delivery from the radiant system on a day when the radiant system can't deliver enough BTUs to keep up with the load, and they use outdoor reset to crank up the radiant heat operating temperature to 120F, or higher. While that's true, it's also true that the best designed air to water radiant systems will be able to deliver what's needed at a fairly low temperature even with severe outdoor design conditions.

So if you can't get enough radiant capacity into the floor, then if possible, add some to the walls or ceiling. Note that radiant heat works just as well from the ceiling or walls as it does from a floor. And in some cases, it works better from the ceiling.

Why does keeping the operating temperature low matter so much?

With a fossil fuel burning boiler, it doesn't matter. Gas, propane, and oil efficiency does not vary with outdoor temperature. But that's not the case with a heat pump.

Here's why:

$$W = \frac{Q_1}{COP_p} = \frac{Q_1(T_1 - T_2)}{\eta_{mech} T_1}$$

For a real-world example, at 0F outdoor temperature, an air to water heat pump such as the CX34 will have >20% higher capacity when used with an operating temperature of 95F compared to operating at 122F. And COP at 95F will be >30% higher at 95F than at 122F.

So why use outdoor reset?

You can use reset when it is simply not possible to design the indoor side of a system to handle the peak BTU load using a low operating temperature. **But the best use of reset is as a strategy for extra energy savings**, by designing the indoor side of the system to handle the peak load at the lowest possible operating temperature, **and then letting the system automatically reset to an even lower and more efficient temperature at times when weather is milder!**

How to Use Chiltrix Dynamic Outdoor Reset Control Use With or Without V18-B Backup Heat (Current Model) **Not For Use With V18 (original model)**

Use the free Excel curve development tool to create the proper curve and discover correct parameter settings for P48 and P49.

The tool is located at <https://www.chiltrix.com/dynamic-heat-reset/>

Set parameter P48 and P49 in cx34 controller according to the values used in your curve.

Enable AU of heat mode as shown below.

There also is an "AU" icon on first page of the standard controller display that will indicate when the AU setting is enabled. The AC target will change according to air temp which you can see from controller 1st page.

“Enable means “Enabled”
 “Disable means “Disabled”

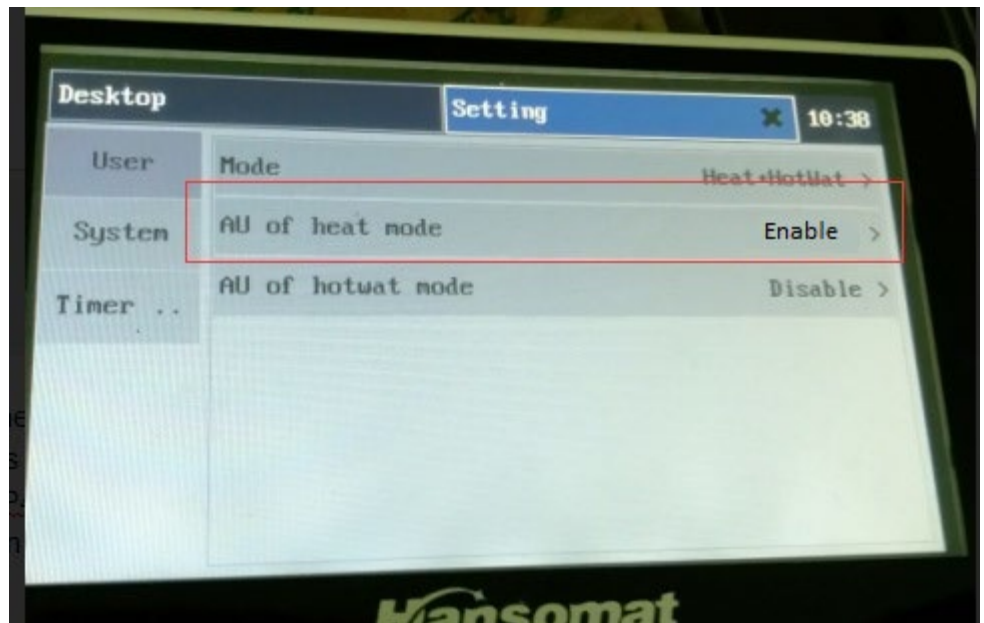

Using Chiltrix Dynamic Outdoor Reset Control with the older V18 (Original Model V18 Uses an External Backup Heat Controller)

If you are using the older original V18 dynamic backup heat, then DO NOT enable Dynamic Outdoor Reset Control in the controller as shown above. You will input the P48/P49 settings as explained above but DO NOT enable AU. Instead, you will enable Dynamic Outdoor Reset Control in the V18 controller manual.

See the old [V18 Backup Heater Manual](https://www.chiltrix.com/hydronic-backup-heater/V18-B-manual.pdf) for more information. The current model V18-B manual is here <https://www.chiltrix.com/hydronic-backup-heater/V18-B-manual.pdf>.

More information about Dynamic Outdoor Reset Control is here <https://www.chiltrix.com/dynamic-heat-reset/>

Commissioning “To Be Performed In Heating Mode Only” An as-built design will need to be provided to Chiltrix by email before the commissioning call.

For Commissioning please arrange a commissioning call with Chiltrix Support Dept. +1 757-410-8640 Ext. 112

PLEASE MAKE SURE TO CALL CHILTRIX BEFORE COMMISSIONING

Preparation

After finishing the installation tasks, please check the items below:

1. Check the Wired Controller P Parameters for the most updated settings.
2. Check that the power cable is securely connected and the screws are tight.
3. Is the display lit on the wired controller after the power is applied?
4. Verify that all the shut off valves and manual valves are open. Insulate all water supply and return pipes.
5. Test only in **heating mode** to verify proper water flow.

Water or Glycol Filling (See page 28) A 10% minimum glycol mixture is suggested to protect the unit from freezing and provide corrosion inhibition. Refer to the chart on page 10.

1. With a hose and filling pump connected to the CX34 water system, and all air exhaust valves open in the water system, fill the water loop with water and glycol mixture. Keep the air exhaust valves open until there is a continuous flow of water and glycol mixture coming out of the air exhaust valve. Then close the air exhaust valves. See page 30 and 31 for more details.
2. Discharge the air from both domestic hot water system and air conditioning water system. CXI fan coils have a bleeder valve located near the inlet and outlet ports. The CX34 has a bleeder tube attached to the Brazed plate heat exchanger.

To avoid freezing the heat pump when the air temperature drops below 32F in winter, you must use an appropriate glycol and water mixture just in case the electricity is cut off. We recommend biodegradable non-toxic SPP Corn Glycol, any Propylene Glycol (PG) can be used.

Running a Test- Call tech support if this is your first time commissioning a CX34.

Apply power to the CX34 and select **heating mode** using the wired controller. If there is not enough flow in the system or air in the lines and you will get P5 and P1 errors. Call tech support if any error codes are displayed on the wired controller.

Chiltrix Tech Support hours of operation, M-F, 9 am-6 pm EST, 757-410-8640 x112

MOST IMPORTANT!

1. Always maintain an electrical connection with heat pump to enable the antifreeze function. 2. Initial test should be done in **heating mode**. Make sure it is not in cooling mode during first operation or running a test, until you make sure the circulation pump is working properly and water is flowing properly. Failure to do so will likely damage the heat exchanger and not be covered under warranty.

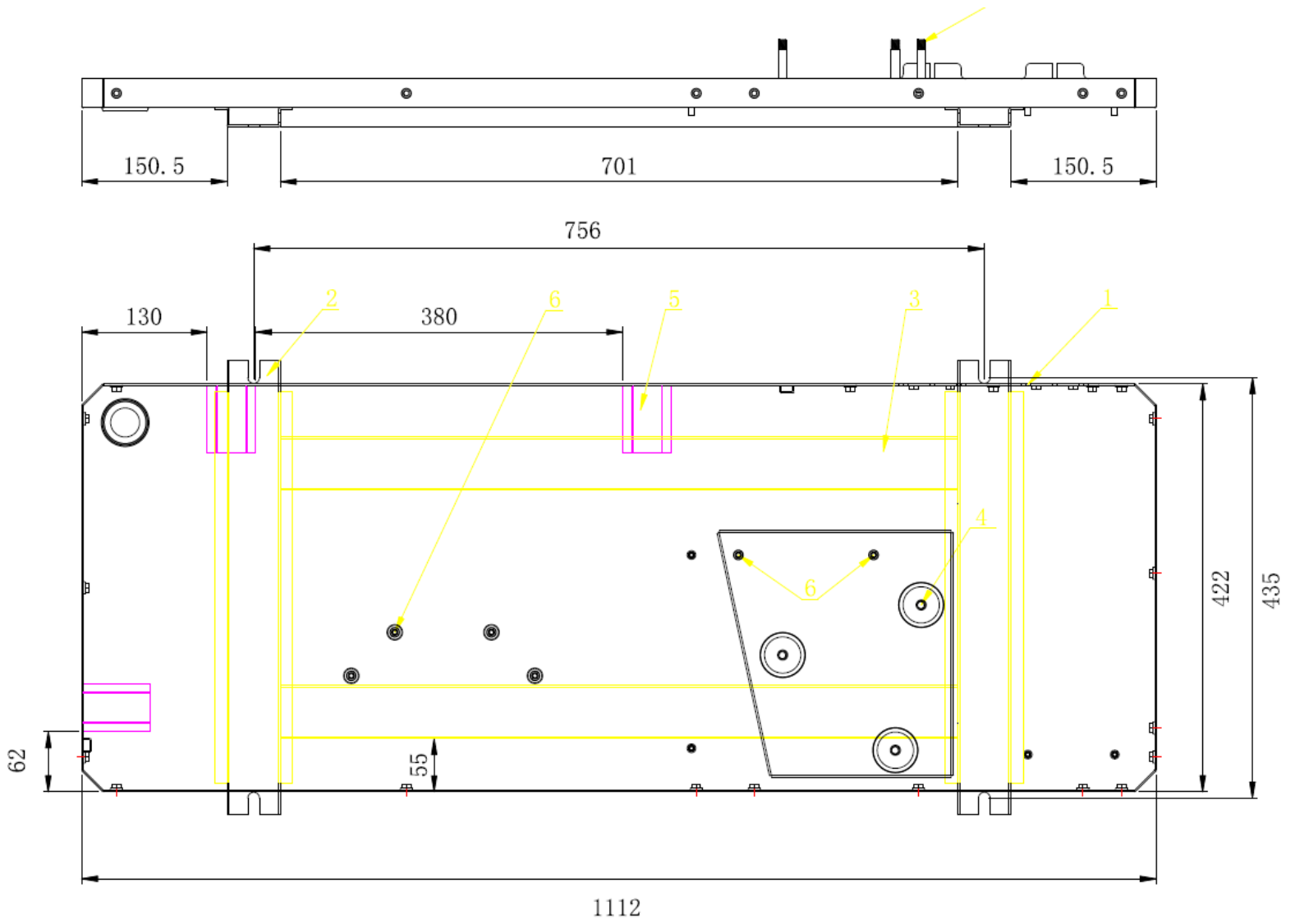

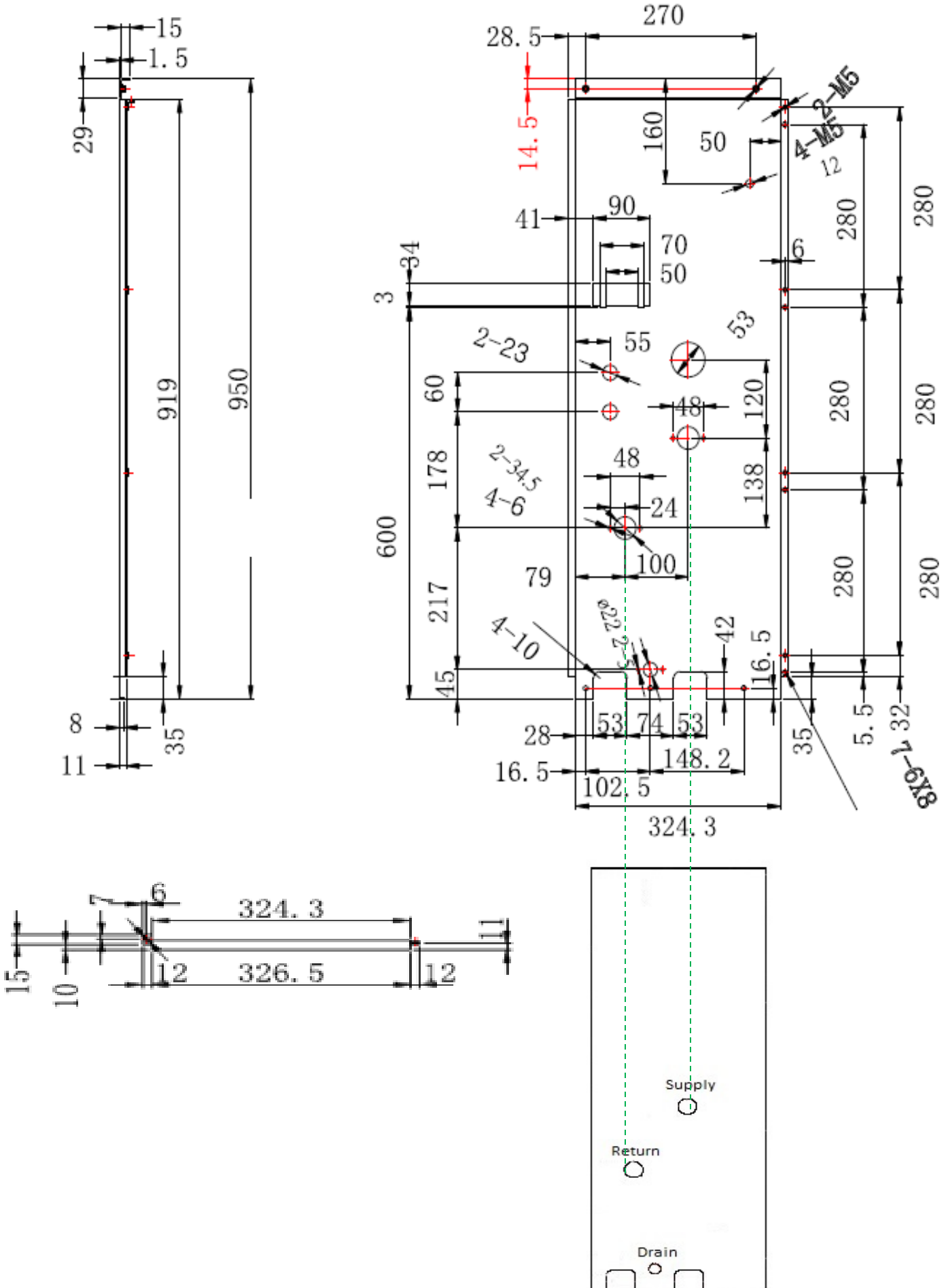

Chiltrix CX34 Internal Pump:
Wilo Yonos PARA RS 25/7.5 PWM1 Ku



Dark Black Line = Chiltrix Pump (25/7.5)

