

## **CX34**

### **DC INVERTER AIR TO WATER HEAT PUMP CX34-4**

**For Use with certain units shipped after 6-15-2022. This applies to CX34 units that have a letter as part of the serial number, example**

**CX34**G**22030693 (If unsure, contact Chiltrix technical support dept.) AND All CX34 in the s/n range (without an letter in s/n) **later (greater) than CX3422025000****

### **Installation and Operation Manual CX34-4**

### **Options for Heating, Cooling and Domestic Hot Water**

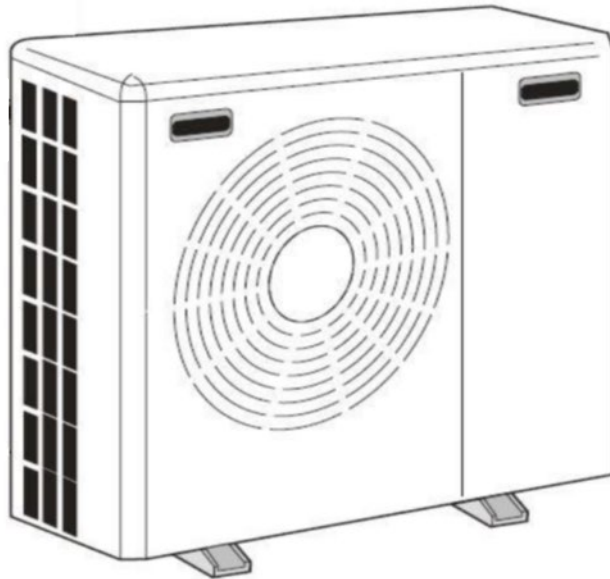

**PLEASE REVIEW ENTIRE MANUAL BEFORE PROCEEDING**

**PLEASE SUBMIT SYSTEM DRAWING & SCHEDULE A COMMISSIONING CALL BEFORE STARTING THE UNIT**

**CX34-4 Version 2.5**

## Table of Contents

Safety Precautions.....	Page 3
CX34 Components.....	Page 4
Hydronic Piping and Design.....	Page 6
Buffer Tanks.....	Page 9
Head/Pressure Drop Calculations.....	Page 10
Using Glycol.....	Page 13
Heat Pump Installation.....	Page 16
Valves G1, G2, G3.....	Page 24
Second Heat Source.....	Page 30
External T-Stat Control.....	Page 31
System Filling/Purging.....	Page 32
Using The Controller/Operation.....	Page 35
Settings Menu .....	Page 36
Administrator Functions and-Parameters.....	Page 43
Mode Switching .....	Page 44
C-Parameters, P-Parameters and Error code Lists .....	Page 46
Dynamic Outdoor Reset Control .....	Page 52
Auto Switch-Over .....	Page 54
Commissioning .....	Page 55
Footprint/Placement Dimensions -----	Page 56
Wilco Pump Flow Curve .....	Page 58

**IMPORTANT NOTE – MAKE SURE TO PROVIDE YOUR DESIGN DRAWING FOR APPROVAL BEFORE GETTING STARTED, INCLUDING DESIRED OPERATING TEMPERATURES.**

### **Safety Precautions**

**NOTE: It is required to read the Safety precautions in detail before operation. The precautions listed below are very important for safety, please follow all safety precautions.**

#### **General**

- All units must have a minimum 10% glycol.
- Make sure that the ground wire in the building is securely connected to earth.
- Wiring tasks should be carried out by qualified electricians only, in addition, they should check the safety conditions of power utilization, for example, verify that the line capacity is adequate, and the power cable isn't damaged.
- Users must not install, repair or relocate the unit. Improper procedures might lead to accidents e.g. personal injury caused by fire, electrical shock or unit's falling off its base, and water leaking into the machine. Please contact a professional service department if problems arise.
- The unit shall not be installed at a spot with the potential hazard of leaking flammable gas. If gas is leaking near the machine, there might be the risk of explosion.
- Make sure that the foundation of the unit is stable. If the foundation is unstable, the outdoor unit may come loose from its base and cause injury.
- Make sure that the GFCI installed at the service panel is working properly to avoid shock or fires.
- If any abnormality occurs in the unit (such as a burning smell is noticed inside the unit), cut off the power supply immediately, and contact a professional service department.
- Please observe the follow items when cleaning the unit. Before cleaning, shut off the electric supply of the unit first to avoid injuries caused by the fan operation.
- Do not rinse the unit with water because the rinsed unit may cause electric shock.
- Make sure to shut off the electric supply before maintaining the unit.
- Please do not insert fingers or sticks into air outlet or air inlet.

#### **Transporting and storage**

The machine must be transported and stored vertically at all times

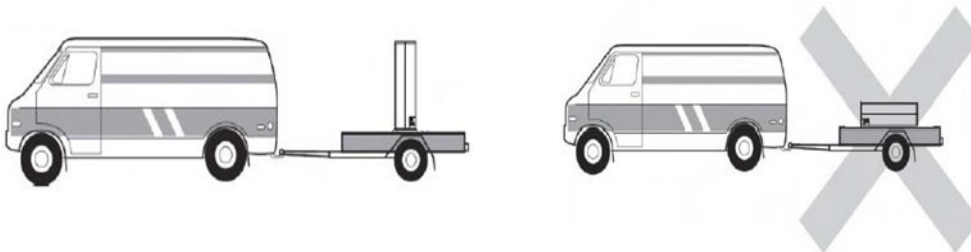

# CX34 Components

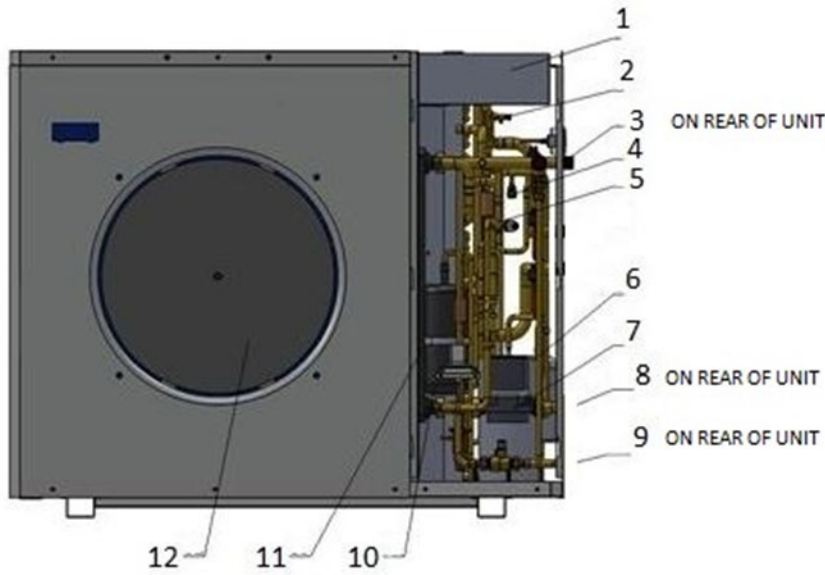

Position	Component	Position	Component
1	Electronics Box	7	Water Pump
2	Air Discharge Valve	8	Heat Pump Inlet
3	Heat Pump Outlet	9	Plate H.E. Drain
4	Needle Valve	10	Accumulator
5	4 Way Valve	11	Plate Heat exchanger
6	Compressor	12	Fan

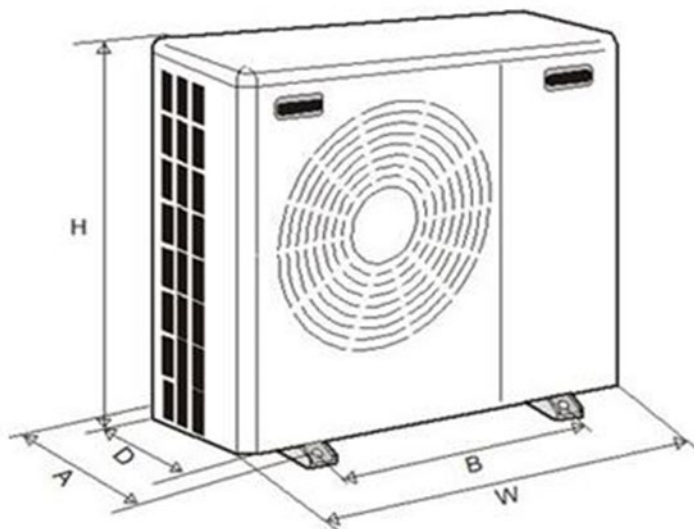

W	44"
D	16.75"
H	38"
A	17.5"
B	29.5"

## CX34 Components

### Ball Valve

Located in the chiller (taped to on of the compressor legs) is a small ball valve used to drain the unit to service the pump or any other internal parts.

**NOTE: You must install this valve or else the unit will leak when filled with water/glycol! Make sure you use Teflon tape on the threads.**



## Hydronic Piping and Design Guide

### Installation Methods Heating and Cooling (Heating Shown)

See Design Guide Here  
<https://www.chiltrix.com/documents/chiller-options.pdf>

**PLEASE ALWAYS SUBMIT YOUR DESIGN TO CHILTRIX FOR APPROVAL**

Note: Primary Secondary Piping or Closely Spaced Tees are NOT supported or recommended for use with this heat pump on the supply-side of the buffer tank, or anywhere in a system without a buffer tank.

A buffer tank must be used for radiant heating. A multi-port buffer tank such as VCT37 should be used to combine multiple heat pumps. Please do not try to balance multiple CX34 units with equal-piping or reverse return design. It will not work as expected due to having multiple variable speed pumps.

An “additional volume” tank must be used when there is no buffer tanks and there is less than 15 gallons of total system fluid volume.

Generic design, not all components shown.

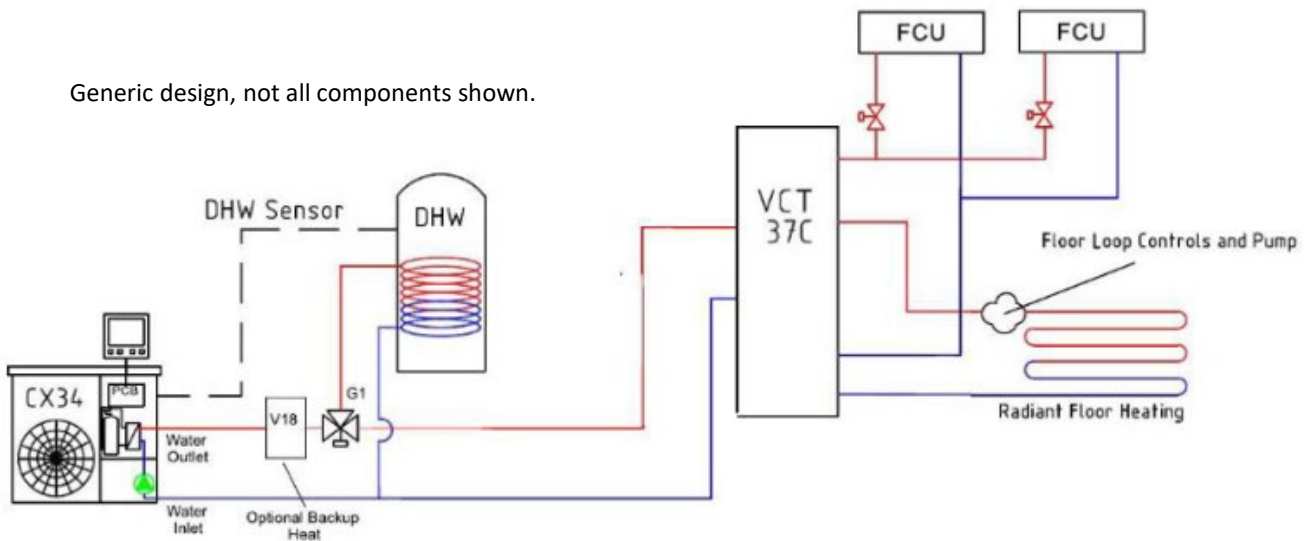

Minimum pipe size should be no less than 1”, CPVC or Oxygen Barrier PEX, reverse return piping is preferable to assist balancing. Reverse-return will not fully balance multiple chillers as the variable speed pumps may not always operate at the same speed. The installer should calculate the pipe and fitting resistance to determine the head pressure. See the examples on the following pages, maximum water flow for the CX34 is 6-7.5 gpm, design flow is 5.2 gpm. If necessary, a second Chiltrix-provided PWM pump may be added to the loop and controlled by the CX34. The second water pump connections are always in series with the internal pump. The loop example above is designed with wild coils (loads). Water flows through the fan coils at all times, if there is a call for heating or cooling the FCU controls will turn the fan on, adjust fan speed, etc. BTU leakage from a wild coil is around the same as a light bulb, not enough to worry about. Valved options are available and Chiltrix fan coil units can support valves, or be used to start/stop a pump, contact Chiltrix support to discuss.

An air discharge valve should be installed at the top of the circulation system, if possible, for easy air discharge. As an alternative an automatic/manual air vent can be used inline before the pumps.

**Always install a water filter or wye strainer on the return side pipe before it enters the heat pump to prevent blockage of the heat exchanger or pump/flow meter problems. A blocked heat exchanger can be a costly problem and is not covered by warranty so make sure to use a filter.**

Do not use CPVC if glycol percentage will be above 25%. Do not use PVC.

## Piping Examples: Stacked Heat Pumps

Preferred Method For 2 or 3 Units:

See Design Guide Here  
<https://www.chiltrix.com/documents/chiller-options.pdf>

**PLEASE ALWAYS SUBMIT YOUR DESIGN TO  
CHILTRIX FOR APPROVAL**

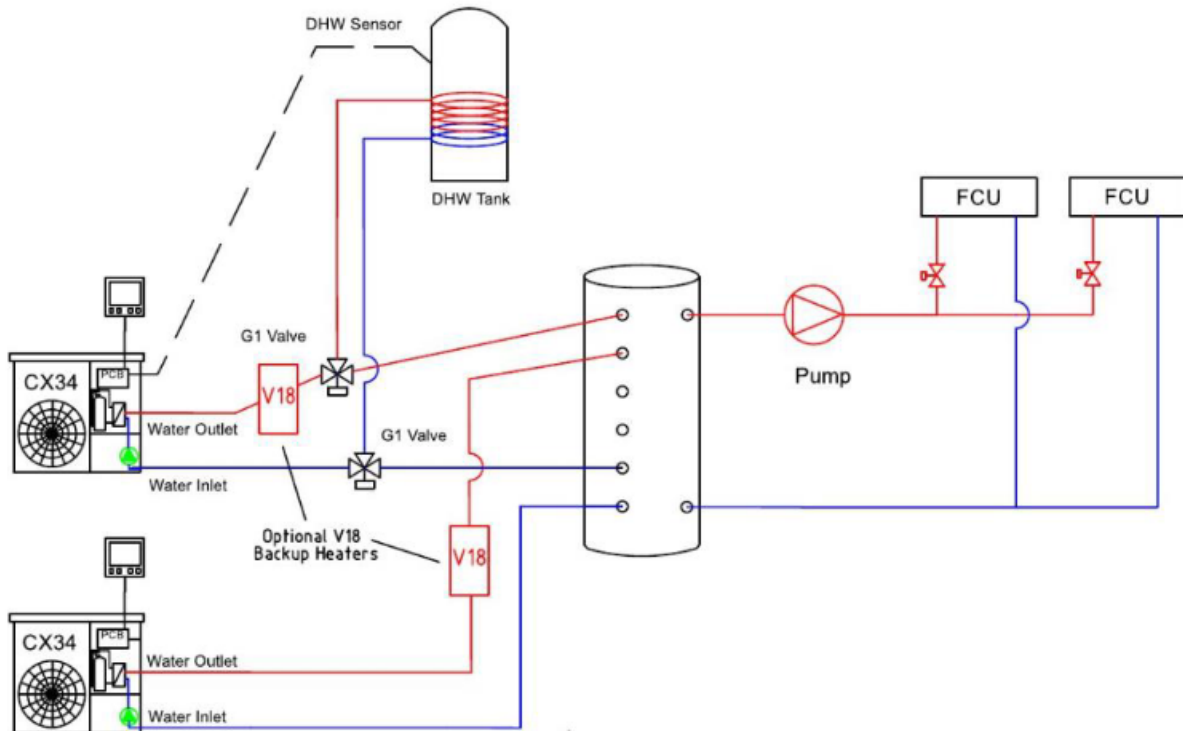

**NOTE about fittings: All Chiltrix V18, tanks, etc., have stainless steel fittings. It is difficult to connect stainless to stainless, we suggest use brass fittings for all connections**

**PLEASE SEND YOUR PROPOSED FINAL DESIGN TO CHILTRIX SUPPORT DEPARTMENT FOR APPROVAL, COMMENTS, AND SUGGESTIONS**

## Piping Examples: Stacked Heat Pumps

Don't Use Primary/Secondary, Manifolds, or Closely Spaced Tees on the supply side to combine multiple outdoor units. Use a Chiltrix multiport buffer tank (VCT37 or VCT60).

**DO NOT PIPE CHILLERS THIS WAY. ALL CHILLERS MUST BE "HOME RUN" TO THE BUFFER TANK.**

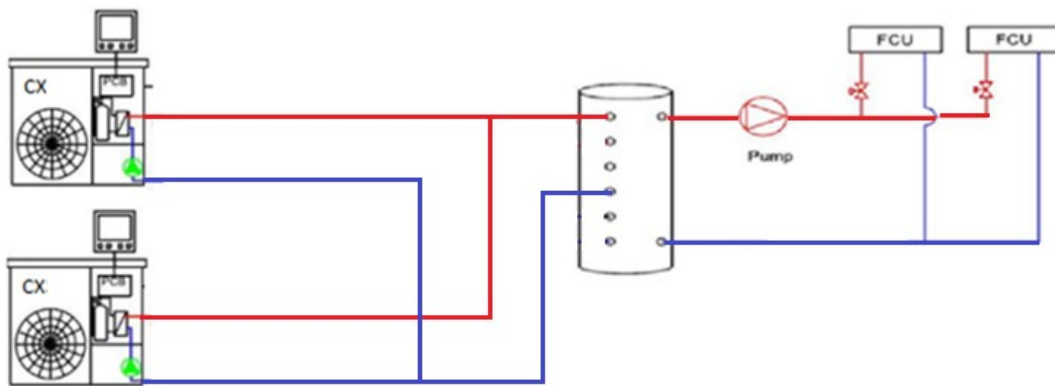

Example of what NOT to do.

## Piping Examples

See Design Guide Here  
<https://www.chiltrix.com/documents/chiller-options.pdf>

**PLEASE ALWAYS SUBMIT YOUR DESIGN TO CHILTRIX FOR APPROVAL**

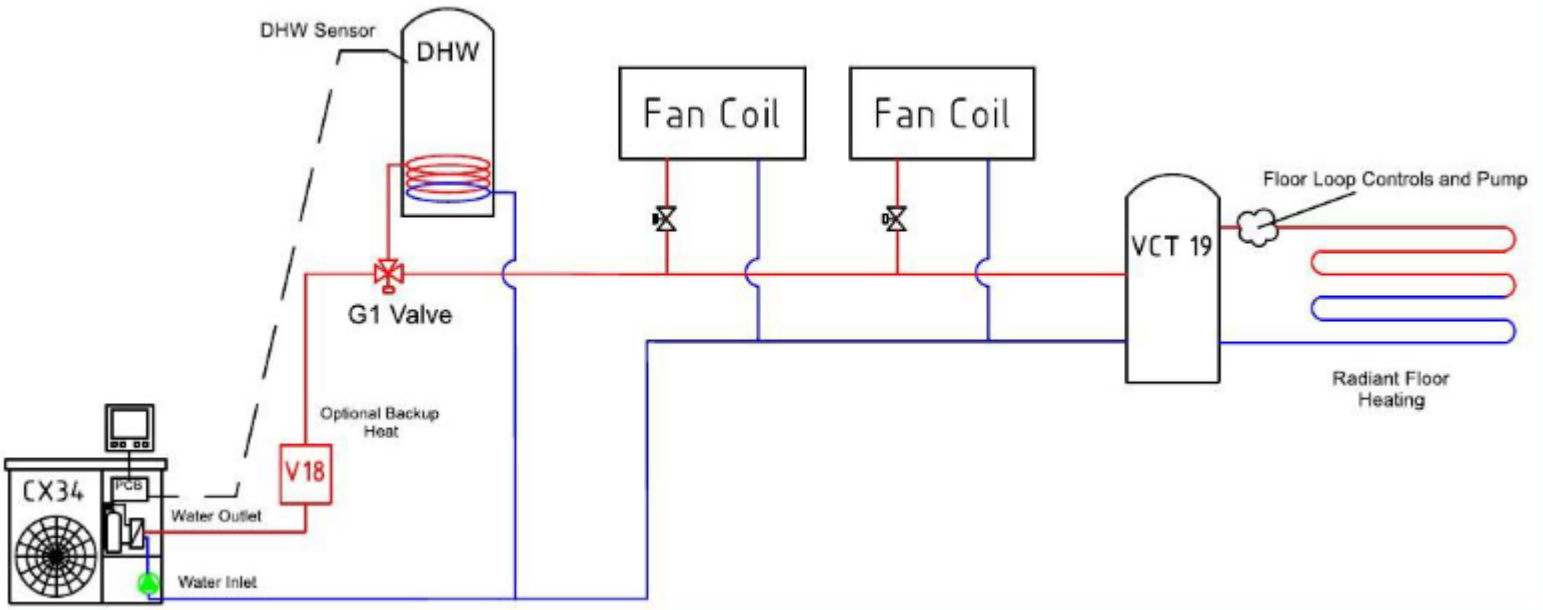

Note: The above design should not be used for more than 2x fan coil/AHU units totaling  $\leq 12$  kbtu capacity. Otherwise, consider using a VCT37 tank and locating the fan coil/AHU units on the load side of a buffer tank.

**PLEASE SEND YOUR PROPOSED FINAL DESIGN TO CHILTRIX SUPPORT DEPARTMENT FOR APPROVAL, COMMENTS, AND SUGGESTIONS**

### Pipe Insulation

All loop piping must be insulated per local and national mechanical codes. Any piping in a system with chilled water (used for cooling) must also be sealed vapor tight to prevent condensate issues. For design tips and a thickness calculator please visit

<http://www.armacell.us/knowledge-center/>

## Using a Buffer Tank w/ Radiant

Example below shows optional DHW, optional V18 backup heater, fan coils, and radiant. The radiant is attached to the load side of a buffer tank.

For V18b information please see the V18b Manual available on the Chiltrix website documents page.

For DHW or buffer tank installation information see the Chiltrix Tank Manual.

**Be sure to check all ports on the tanks to ensure each oring/gasket is lubricated and tight to prevent leaking.**

See Design Guide Here  
<https://www.chiltrix.com/documents/chiller-options.pdf>

**PLEASE ALWAYS SUBMIT YOUR DESIGN TO CHILTRIX FOR APPROVAL**

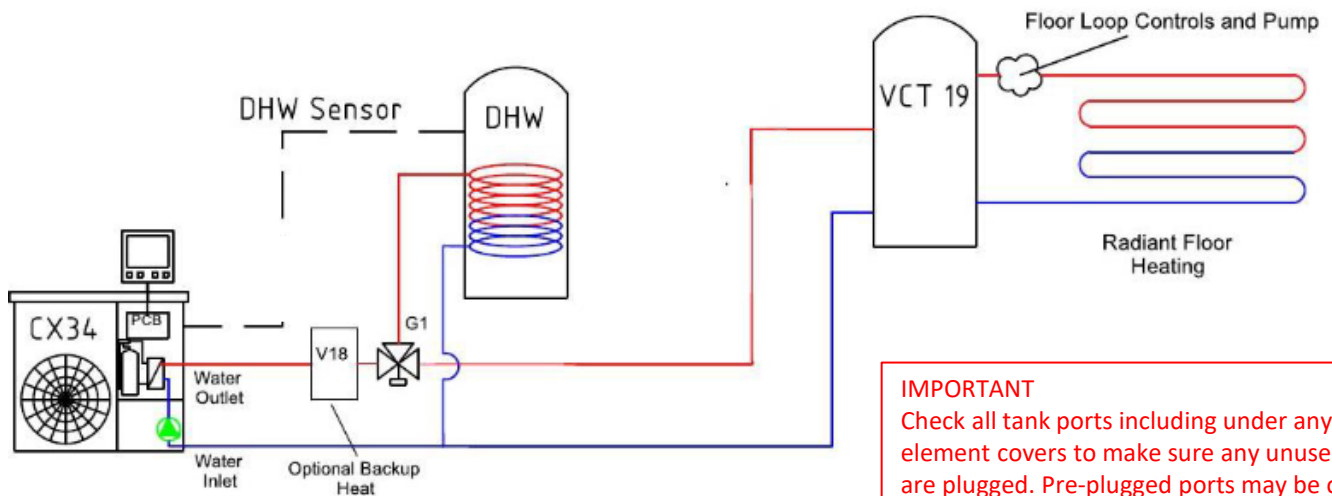

**IMPORTANT**  
 Check all tank ports including under any element covers to make sure any unused ports are plugged. Pre-plugged ports may be only finger-tight. Check ALL ports and plugs for water tight fit.

**Primary / secondary piping is not supported, when connecting to a floor heating loop always use a buffer tank. Buffer tanks are not always needed (except for radiant, they are always needed) with the Chiltrix system, or to combine multiple heat pump outdoor units, but are still always recommended to improve performance.**

### IMPORTANT NOTE ABOUT BACKUP HEAT

**Do not ever use heating elements in a buffer tanks for backup heat. The element capabilities of the buffer tank are provided for emergency heat only. Not “backup” heat. Contact Chiltrix with any questions about emergency or backup heat options. See details in the Chiltrix Tank Manual.**

The radiant loop pump in the buffer tank drawing is controlled by the customer’s manifolds, floor loop controls, valves, load-side pump, etc. The buffer tank isolates the pumps from each other providing hydraulic separation and thermal buffering.

A 19 gallon buffer tank is used generally for best performance with a single CX34. 30-45 gallons is used for systems of two or three CX34s, and is always used when multiple CX34s are to be combined.

See more designs here:

<https://www.chiltrix.com/documents/chiller-options.pdf>

### Head Calculation Example:

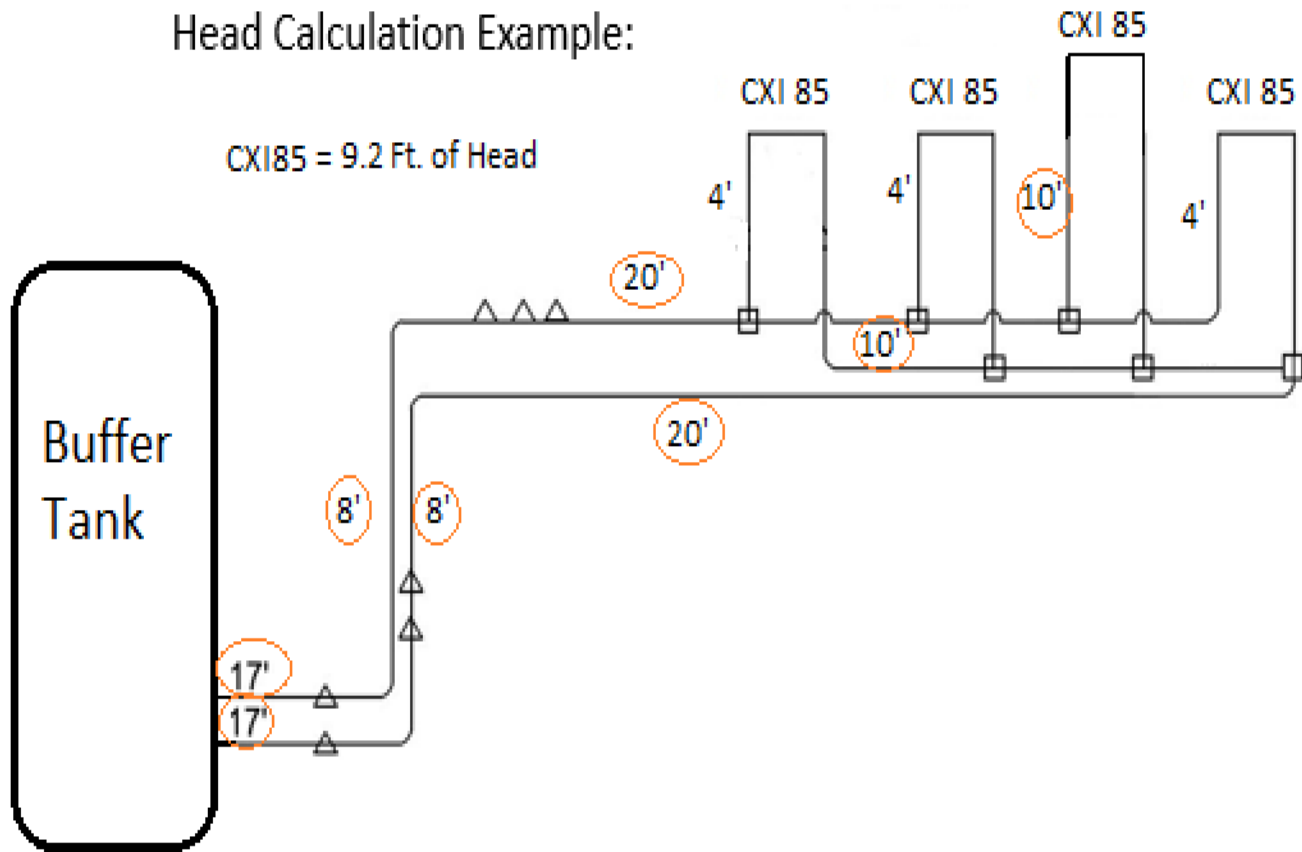

To calculate the head pressure for the correct water flow, the pipe length must be measured and all fittings counted. It is advisable to use flexible red oxygen barrier PEX piping and route it so as to avoid as many elbows as possible.

All fittings have an equivalent length of pipe already calculated, available on the next page under PEX Fittings Pressure Drops.

All measurements in feet

6 Tees @ 2.3ft. Of pipe = **13.8** ft. of pipe

7 Couplings @ 1.3 ft. of pipe = **11.7** ft. of Pipe

**120'** of actual Pex Pipe

**145.5'** of Pex @ 4.76 GPM and 10% Propylene Glycol

145.5' x .05 = **7.02** ft. of Head per chart

CXI 85 Fan Coils = **9.2** ft. of Head

Total Head = **16.2** ft.

## Head Calculations - Continued:

The previously shown example loop has a volume of 4.5 gallons. The internal thermal expansion tank is 2 liters or .52 Gallons. The volume of the CX34 is 4.5 liters. An additional thermal expansion tank may be required for larger loops. There are many thermal expansion calculators on the internet, the following is an example.

<http://westank.com/calculator/>

Minimum loop pressure is 14.5 psi, maximum pressure is 43.5 psi, and ideal pressure is 29 psi. The lowest temperature is 44°F, the highest temperature is 131°F, the Initial pressure is 14.5 psi, and the final pressure is 29 psi.

A microbubble air separator should be installed in the loop preferably in the higher part of the loop to remove any air in the circulation loop. Always install a water filter or wye strainer on the supply pipe to the chiller to prevent blockage of the heat exchanger or damage to flow meter.

Nominal size	OD	Wall thickness	ID	Volume gal/100'
3/8"	0.500	0.070	0.350	0.50
1/2"	0.625	0.070	0.475	0.92
5/8"	0.750	0.083	0.574	1.34
3/4"	0.875	0.097	0.677	1.83
1"	1.125	0.125	0.863	3.03



WYE STRAINER (from supplyHouse.com)

**THE WYE STRAINER SHOULD BE CLEANED OUT AFTER 1-2 DAYS OF OPERATION TO REMOVE ANY COLLECTED DEBRIS REMAINING FROM INSTALLATION**



Watts AS-MB  
Microbubble Air Separator

### PEX Brass Crimp Fittings Friction Loss - Equivalent Feet of PEX Tubing

Size	Coupling	Elbow	Tee Run	Tee Branch
3/8"	2.9	9.2	2.9	9.4
1/2"	2.0	9.4	2.2	10.4
3/4"	0.6	9.4	1.9	8.9
1"	1.3	10.0	2.3	11.0

## GRUNDFOS UPMM 15/25-95 230V PWM

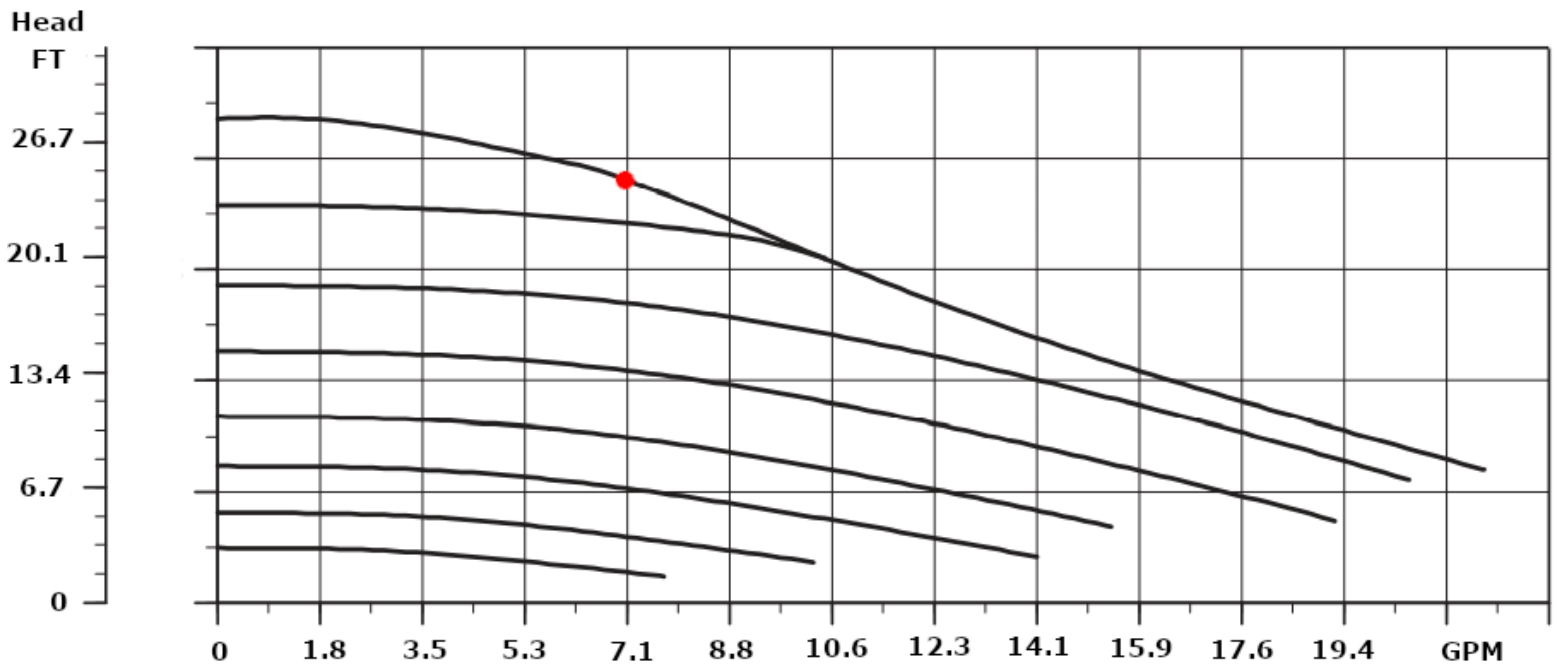

This is the Grundfos pump head curve for Chiltrix CX34 and is shipped with 2021 and newer CX34 units.

Note, the CX34 itself has 4.5 Ft. Head.

This leaves about 19ft of head net of the chiller.

# Glycol

A minimum of 10% of glycol is required in every system no matter the climate. Customers in colder climates that are subject to occasional freezing should add an appropriate percentage of food-grade propylene glycol to the system. NEVER USE ETHYLENE GLYCOL. Ethylene Glycol is a poison. Propylene Glycol is a non-toxic anti-freeze also used in food, cosmetics, etc. and can safely be used. **IF YOU ARE IN AN AREA THAT MAY HAVE <32 °F WEATHER YOU SHOULD CONSIDER GLYCOL. FREEZE IS NOT COVERED UNDER WARRANTY.**

Food-Grade Glycol is available at Home Depot and other retailers. You may also consider HSE Corn Glycol (Biodegradable Food-Grade Glycol made From Corn

<https://www.hotspotenergy.com/corn-glycol/>

Below is a Freeze Point Chart For Propylene Glycol Mixed w/ Water

		Freezing Point						
Propylene Glycol Solution (%)	by mass	0	10	20	30	40	50	60
	by volume	0	10	19	29	40	50	60
Temperature	°F	32	26	18	7	-8	-29	-55
	°C	0	-3	-8	-14	-22	-34	-48

## Flow Rates

### Required flow rate changes with the glycol %.

Note the “500” formula water factors are adjusted as follows (based on 2,3 tons capacity):

00% glycol use  $500 \frac{24,000}{500/10}=4.8$  GPM  
 10% glycol use  $494 \frac{24,000}{494/10}=4.85$  GPM  
 20% glycol use  $488 \frac{24,000}{488/10}=4.91$  GPM  
 30% glycol use  $480 \frac{24,000}{480/10}=5.00$  GPM  
 40% glycol use  $463 \frac{24,000}{463/10}=5.18$  GPM  
 50% glycol use  $442 \frac{24,000}{442/10}=5.43$  GPM

00% glycol use  $500 \frac{36,000}{500/10}=7.42$  GPM  
 10% glycol use  $494 \frac{36,000}{494/10}=7.28$  GPM  
 20% glycol use  $488 \frac{36,000}{488/10}=7.37$  GPM  
 30% glycol use  $480 \frac{36,000}{480/10}=7.50$  GPM  
 40% glycol use  $463 \frac{36,000}{463/10}=7.77$  GPM  
 50% glycol use  $442 \frac{36,000}{442/10}=8.14$  GPM

### NOTE:

When using **CPVC piping** it is highly recommended that you do not exceed a 25% glycol to water ratio. Environmental Stress Cracking, also referred to as ESC, may occur. Do NOT use PVC piping.

Example:

Based on load calculations a given system needs to deliver a maximum of 31,000 BTU with 30% glycol:  
 $BTU/31,000/480=6.45$  GPM  
 (BTU/water factor=required flow rate)

Use the required flow rate to calculate head based on the Head Flow Curve on the following page.

Minimum pump operating speed can be set at P69, minimum speed setting used should not produce a flow rate in your system of less than 9 L/min and generally should not be set lower than 40%. Pump speed can be monitored at C51, 1 is lowest (idle, when compressor off) and 10 is highest speed. Actual water flow can now be monitored on the desktop and at C47, liters per minute. **Test at full pump speed.** 1 L/min = .264 GPM // 1 GPM = 3.78 L/min

# Chiltrix Heat Pump Installation

## Heat Pump Installation

### Installation position

**Note: Installation must be carried out by professional personnel.**

The recommended mounting pad should be at least 1 ½” above ground level. If you are in an area where snow occurs, mount the unit high enough above grade to avoid blockage by drifting snow. You can consider a properly rated wall mount if desired.

Proper drainage is required at the heat pump unit to avoid flooding the outdoor unit with water or ice. Make sure condensate has a way to rapidly and completely drain away from the unit.

To install the unit on a balcony or on top of a building, the installation site must meet the allowable load bearing capacity of the building structure without affecting the structural safety. Ensure the unit is well ventilated; the direction of air exhaust should be kept away from the windows of neighboring buildings.

Adequate service clearance should be kept around the unit. The unit should not be installed in places accompanied with oil, inflammable gases; corrosive components e.g. sulfur compound, or high-frequency equipment.

**No obstacle in front of the unit**

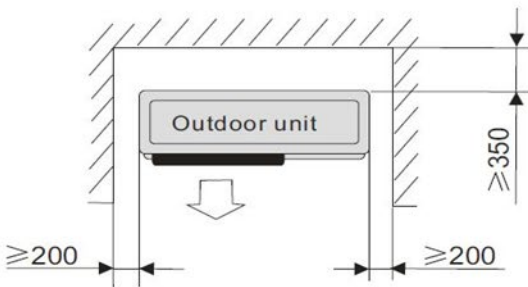

**Obstacle above the unit**

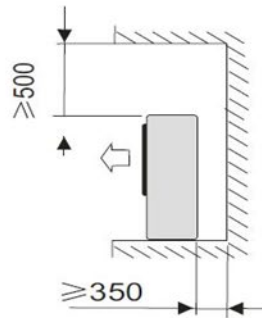

**Obstacle in front of the unit**

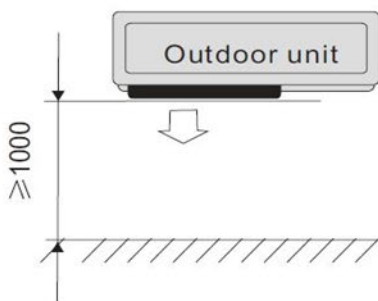

**Several units in a row**

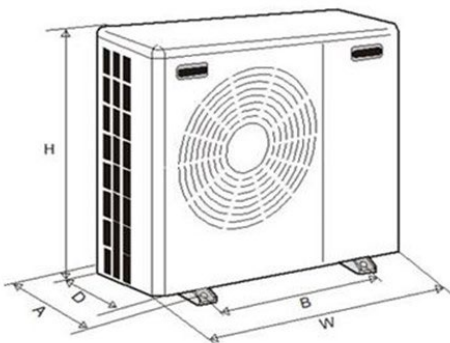
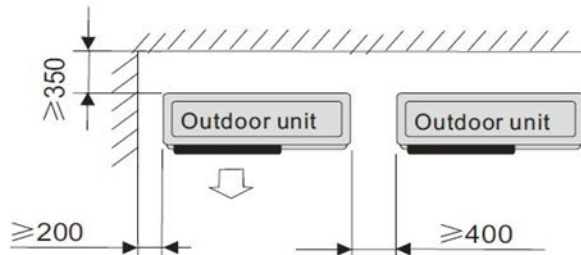

W	44"
D	16.75"
H	38"
A	17.5"
B	29.5"

**Outdoor Unit Placement / Clearances**  
 (Unit: mm) 200mm = 8" , 350mm =14 " ,  
 400=16" , 500=20" ,1000=40"

### More about Location:

You don't want it in a "pit" or enclosed area where air flow could be impaired or where fan output could be prevented from rising away in summer, or could stratify cold output in the heating season and cause an artificial drop in ambient temp.

## Chiltrix Heat Pump Installation

**NOTE:** The CX34 is shipped with the pump in a separate box attached to the top of the chiller. Please follow the directions below to install the "C4" Grundfos internal pump.

### Internal Pump Installation

(Remove Top, Front, and Right Side Covers) **DO NOT BEND OR STRESS THE PIPING, this may cause a broken joint or leak where it joins the heat exchanger.** Cut the insulation and peel it back out of the way of the flange nuts. This will allow installation of the pump without bending either of the pipes. The pump will slide in between the pipes with the washers.



Peel back the insulation



Removing the shipping spacer



Note the orientation of the arrow on the pump body, this arrow must point upwards.

# Internal Pump Wiring

V18	Pump
PWM	PWM
CN46	CN45
+ -	+ -

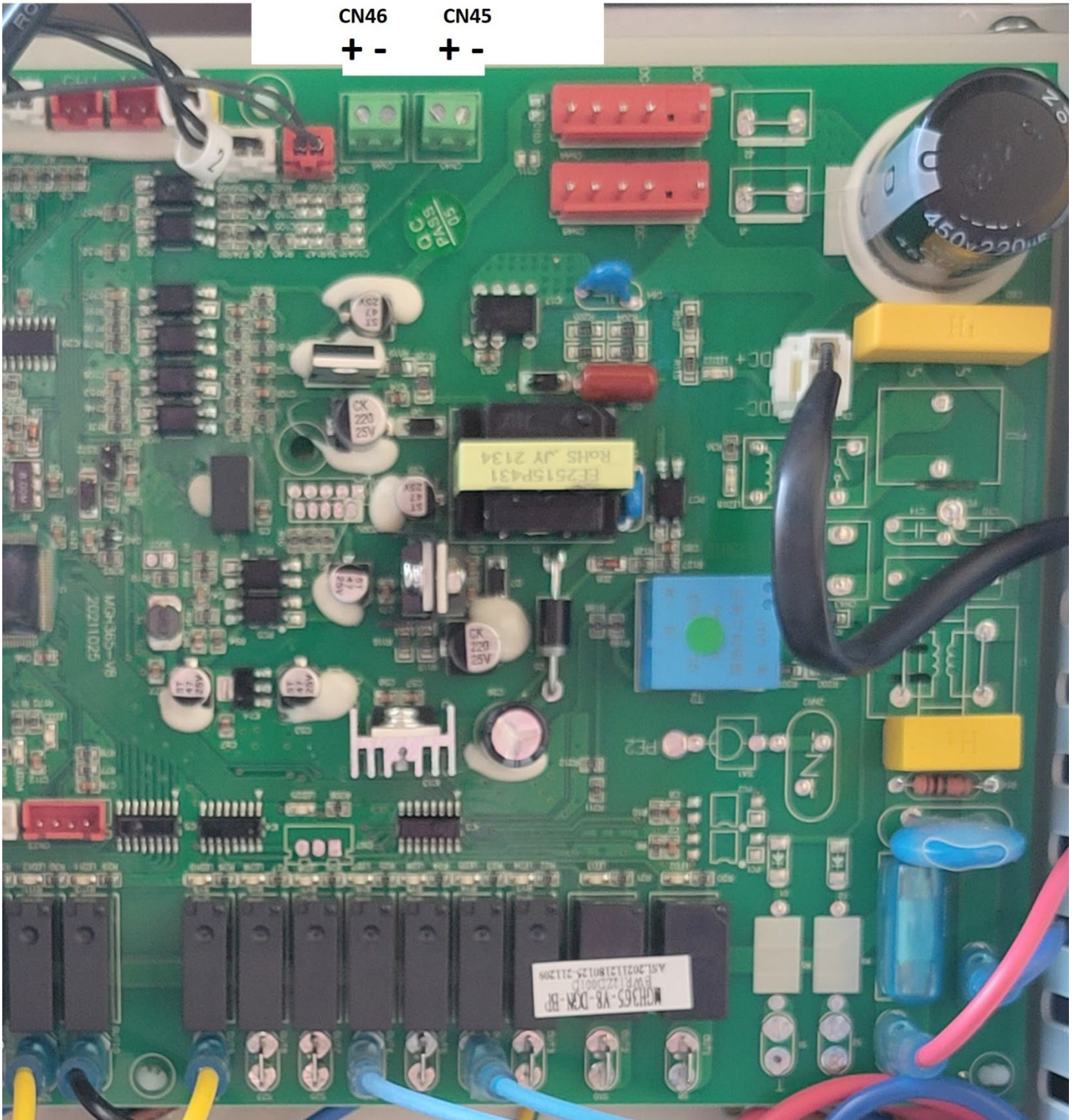

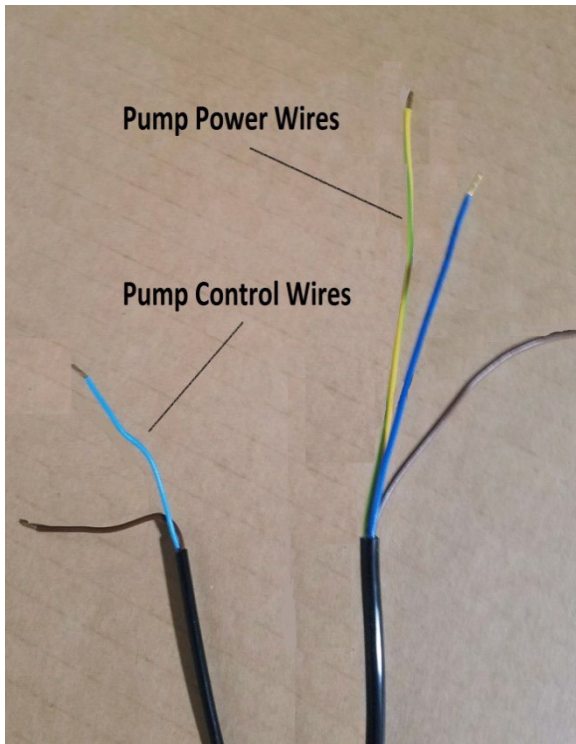

V18	Pump
PWM	PWM
CN46	CN45
+ -	+ -



The blue and brown pump **CONTROL WIRES** are connected to the (+ & -) on the Pump PWM terminal connector at the top of the main control pcb.



Pump **POWER** wire

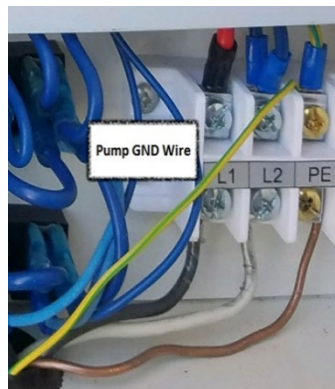

Pump **GROUND** wire

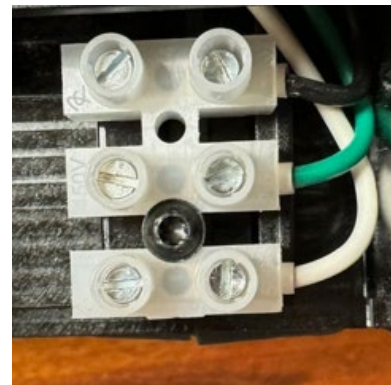

Pump Power (pump)

Note- CX34 UPMM pump ships with control cable and a plastic bag that includes the electrical box cover/screw and the gaskets. This pump does not ship with the power cable which is to be supplied by the installer. At pump, white and black connect to CX35 C4L and L2, green yellow is frame ground. See [Grundfos Pump Wiring](#) supplement on page 59 for more info.

## Electrical Connection

### General

#### **Note!**

***Electrical installation and service must be carried out under the supervision of a qualified electrician. Electrical installation and wiring must be carried out in accordance with the NEC.***

The heat pump must be connected under the supervision of a qualified electrician. Wires, spare parts and materials etc. must satisfy the relevant standards and codes issued by the host country or region. The heat pump does not include an AC disconnect or switch on the incoming electrical supply which will be required. The power supply cable must be connected to a circuit-breaker with at least a 3 mm breaking gap. Incoming supply must comply with the technical requirements, with a frame ground wire (neutral is not used), via a distribution box with breakers. **Allowed Voltage range is 208-240vac. Maximum current draw is 13.9 amps, minimum wire size is 12 AWG, minimum breaker size is 20 AMP.**

**It is the responsibility of the customer to provide clean power, 208-245v 1P 60Hz without power surges. It is advisable to add surge suppression with transient voltage protection to the circuit powering the heat pump. Clamping voltage of the device should be less than 400v.**

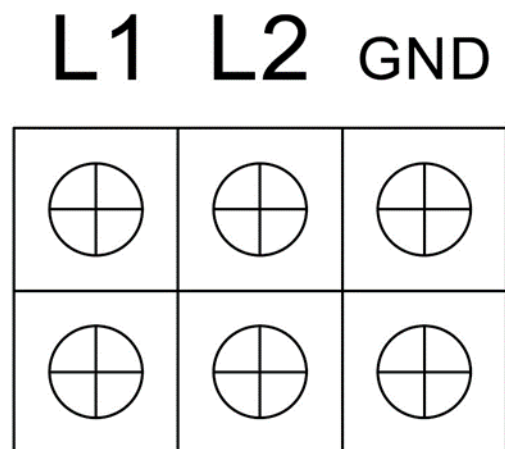
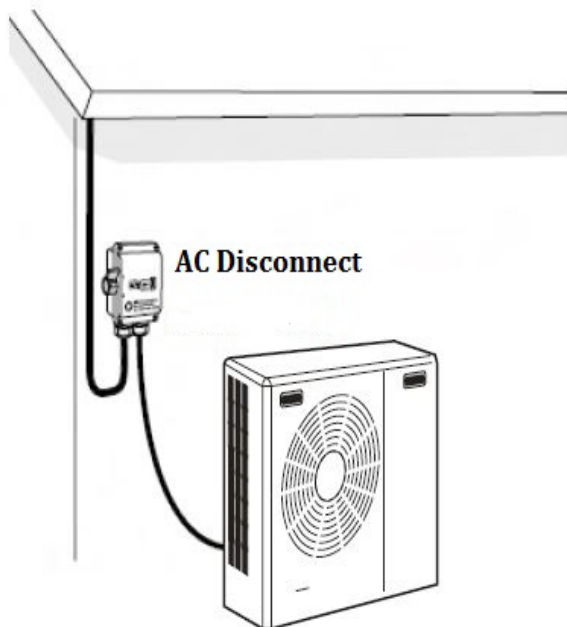

Main terminal block inside electronics box

Example MOV transient voltage suppressor

<https://www.mouser.com/?Keyword=V300LA40AP>

## Electric Connections and Component Locator

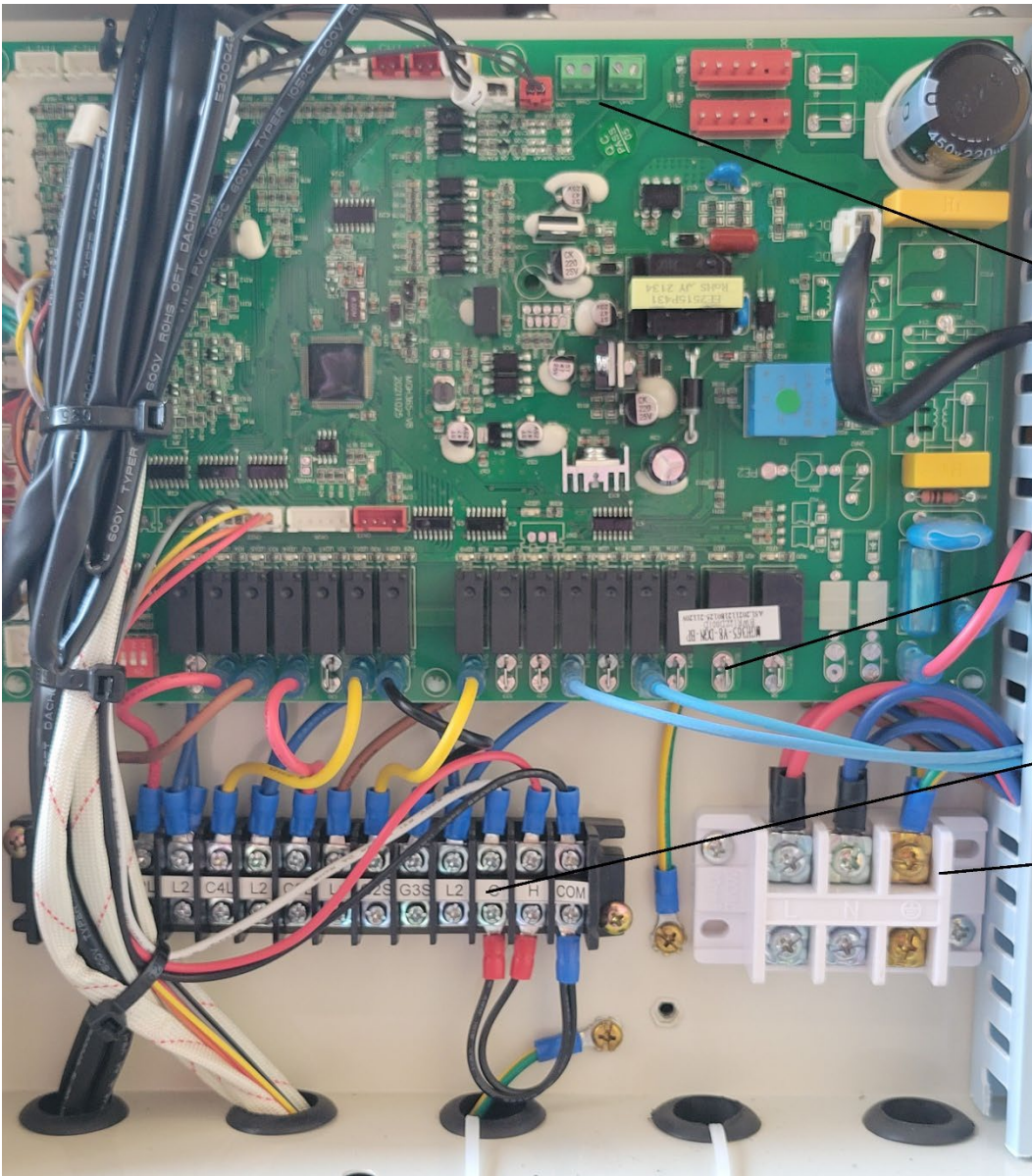

PWM Connectors  
CN46 = V18 Control  
CN45 = Pump Control

OUT Connectors

Main Terminal Strip

Main Power In

# CX34 System Wiring Diagram

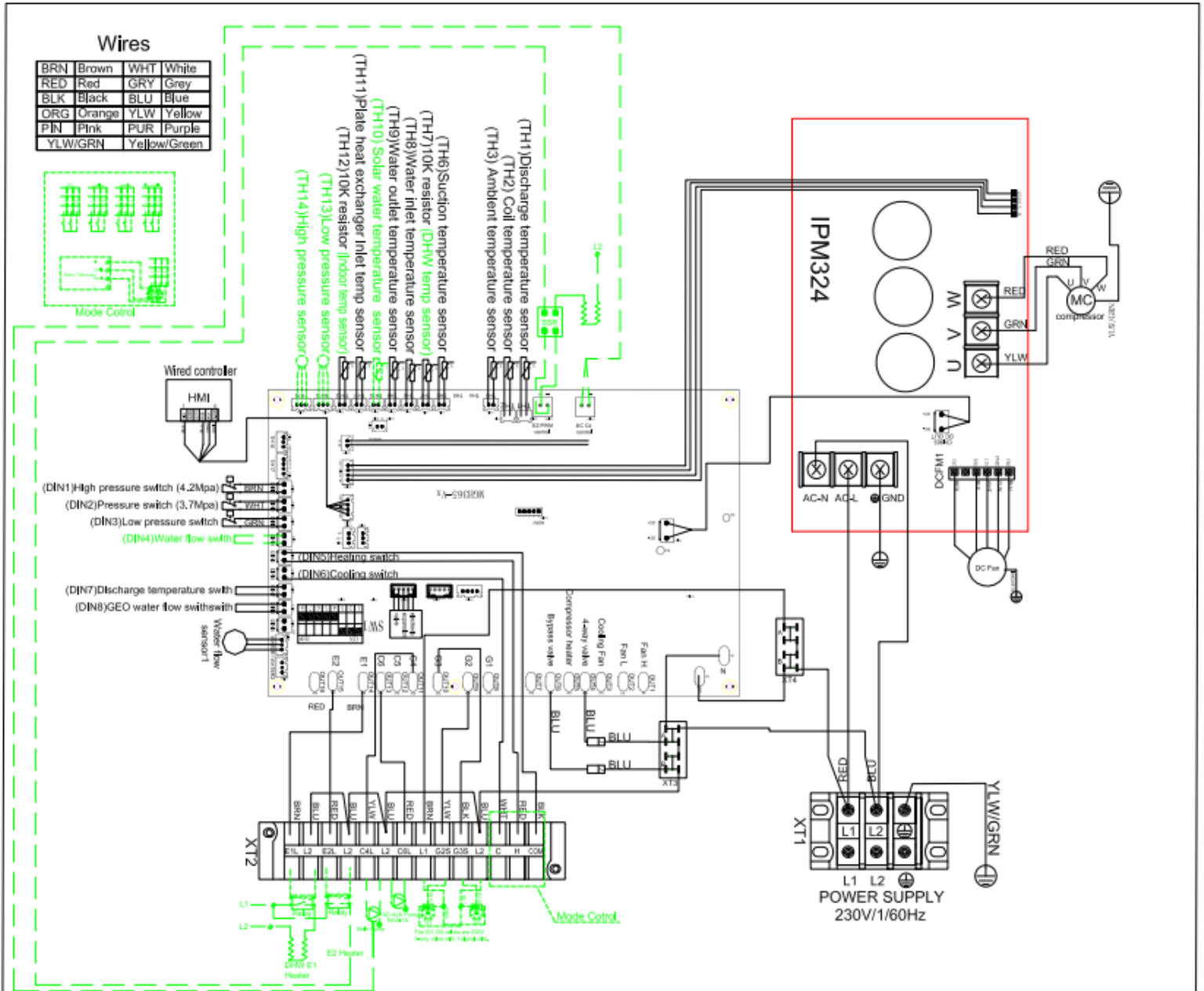

## When using a second NON-PWM water pump

Generally there should be no need for this, please consult Chiltrix support dept. with any questions.

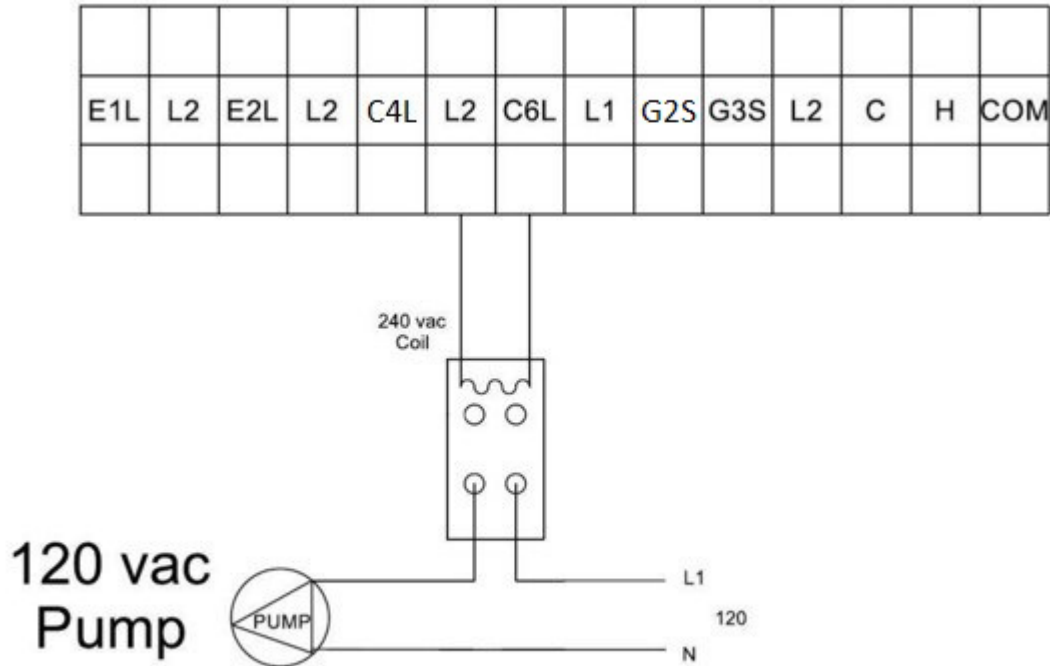

Connect the fixed speed pump to L2 and C6L.

When using a second NON-PWM water pump, use terminals L2 and C6L for relay coil power only. Do not connect a pump directly to L2 and C6L, always use a relay with a 240 vac coil. This pump will only run when the PWM pump is running. **Setting P26=1, and P67=1, will shut C6 off when the chiller reaches its set point.**

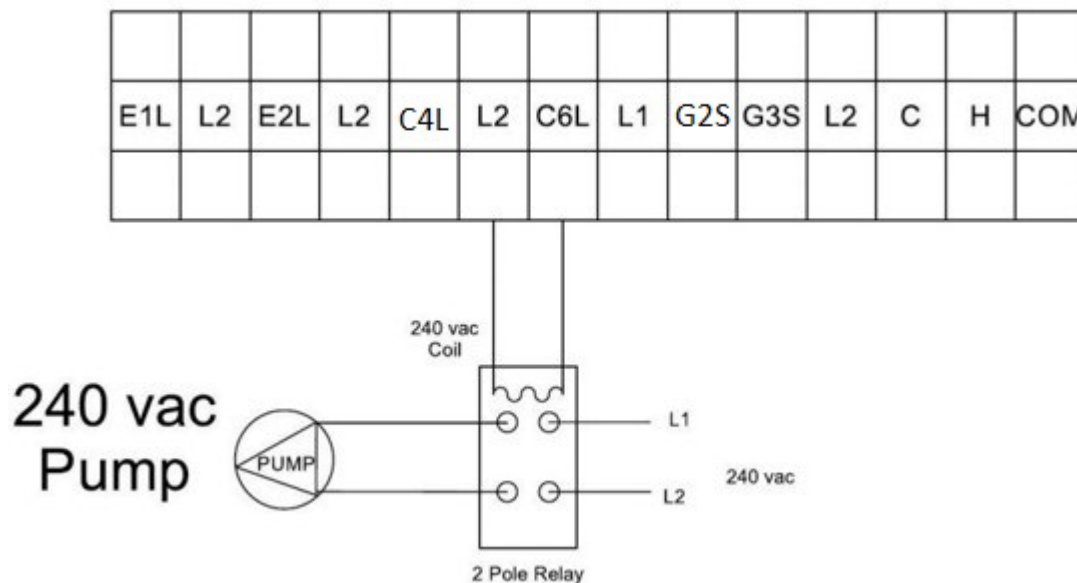

## DHW (Domestic Hot Water) G1 Valve

G1: DHW/AC / Heating 3-Way Valve

In DHW mode, the G1 valve is powered off. In AC/heating mode, G1 is powered on. Parameter P56 must be "1" to enable DHW.

**G1 and G3 valves use 220v Primary from the CX34. Use conduit and install per local code.**

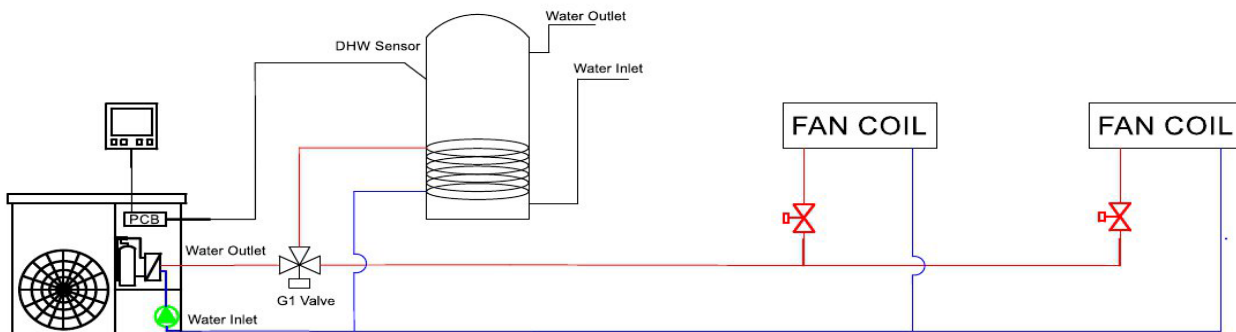

DHW target setting temperature is the tank water temperature measured with the DHW sensor, not the CX34 inlet water temperature. If the target temperature is 120°F, and the differential is 2°C, it means, when the DHW tank reaches 120°F, the compressor will stop. When the DHW tank temperature is lower than 116°F, DHW will start. **See the Chiltrix Tank Manual before proceeding to install or connecting any DHW or buffer tank.**

See the Chiltrix Tank Manual for important details and options for using CX34 with DHW, including backup heat options, and anti-legionella function. **READ THE CHILTRIX TANK MANUAL BEFORE DESIGNING, CONNECTING, CONFIGURING, OR USING DHW.**

The indoor ambient air temp is not used at this time, however, **do not disconnect this sensor. Leave all unused sensors plugged in and wrapped in the bundle above the compressor.**

**IMPORTANT**  
Check all tank ports including under any element covers to make sure any unused ports are plugged. Pre-plugged ports may be only finger-tight. Check ALL ports and plugs for water tight fit.

Note; There is a clear plastic bag taped to the CX34. It contains the mounting feet, DHW sensor, and controller cable. Controller is inside.



## DHW (Domestic Hot Water) G1 Valve

### DHW and AC / Heating with two chillers in Parallel

G1 and G3 valves use 220v Primary from the CX34. Use conduit and install per local code. Below shows 2x G1 valves, used this way so that Chiller 2 can continue to provide cooling or heating while Chiller 1 deals with any DHW load. Bottom drawing shows 1x CX34 properly used with only one G1 valve.

The G1 valve should be installed as close to the CX34 as practical. The DHW tank should be installed as close to the G1 valve as practical. Shorter distances will improve performance and reduce the likelihood of needing a booster pump. The CX34 should always be located within 50 ft. of the DHW tank.

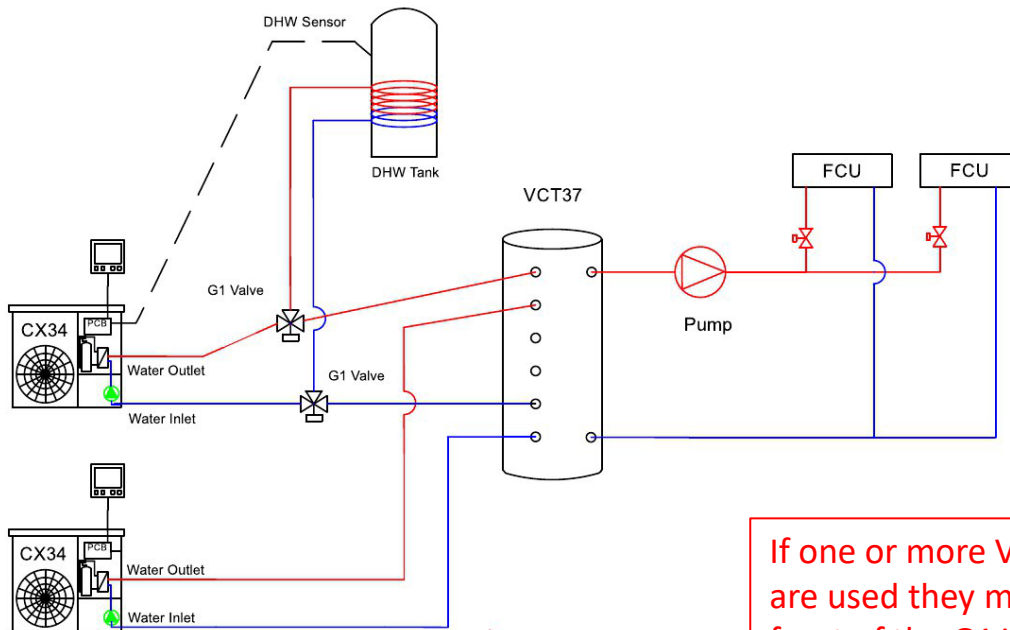

If one or more V18b units are used they must be in front of the G1 Valve (upstream from G1) See V18b manual.

**IMPORTANT**

Check all tank ports including under any element covers to make sure any unused ports are plugged. Pre-plugged ports may be only finger-tight. Check ALL ports and plugs for water tight fit.

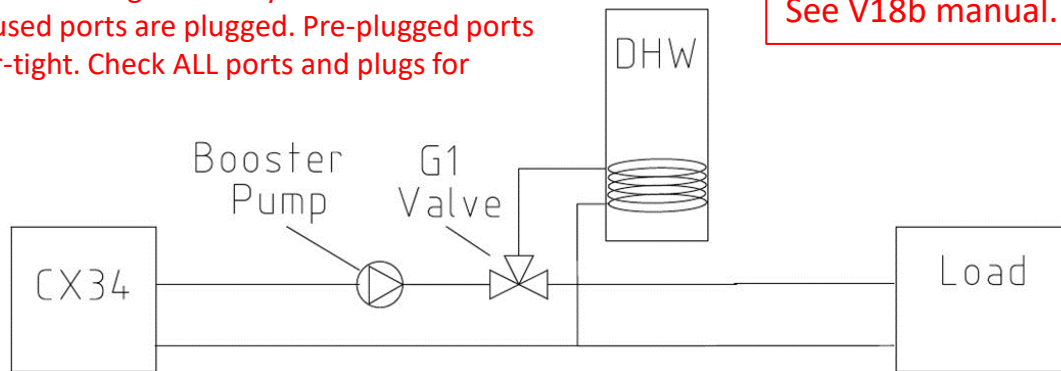

Any booster pump should be located between the heat pump outlet and any G1 valve or V18

## G valves Continued

A booster pump may be installed in front of the G2 valve when installing the DHW option if the head, including pressure drop of the DHW tank coil, exceeds the head allowed by the pump curve when calculated at 7GPM. If a booster pump is needed for a different reason, this location should also be used. Check the DHW tank pressure drop from the Chiltrix Tank Manual or tank provider coil specs if not using a Chiltrix tank. The G2 valve should be located as close to the cx35 as practical.

**G2 Valve Wiring** Note; The G2 control wire is connected to G2 on the terminal strip G2 and G3 valves use 220v Primary from the cx35. Use conduit and install per local code.

Be sure to review this document and follow the proper procedure for all rubber oring/gasket fittings. The recommended lubricant is silicon grease. If the rubber is not lubricated then the oring/gasket will tear.

<https://www.chiltrix.com/documents/Chiltrix-3-way-valve.pdf>

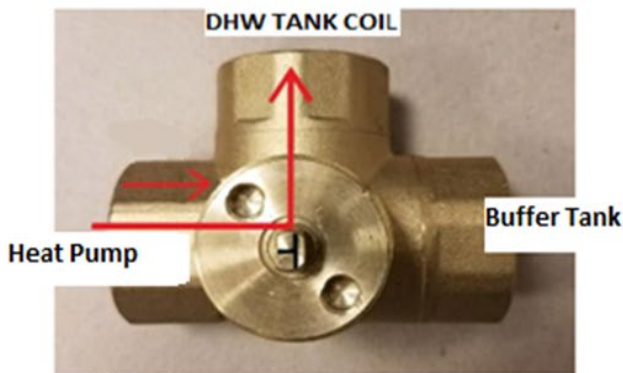
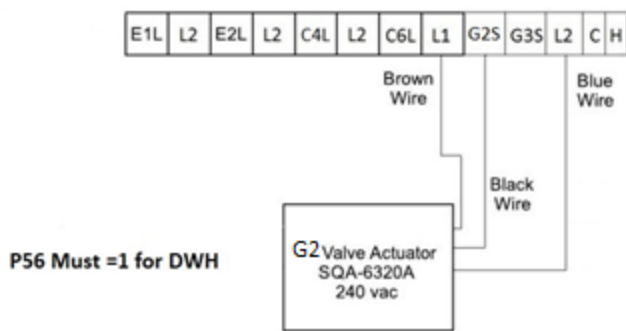

Figure 1  
G1 Valve Active, DHW Mode

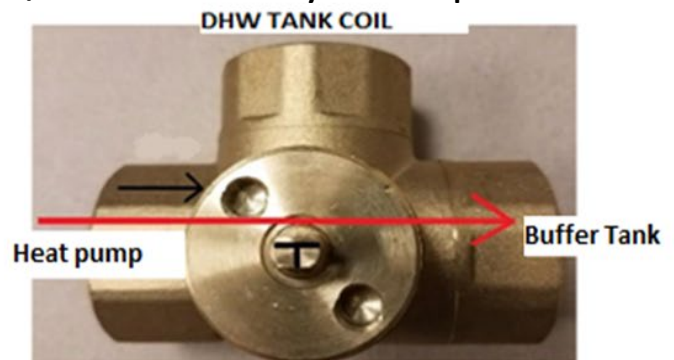

Figure 2  
Heating and Cooling Only

Figure 1, this is the direction of flow when it is activated for DHW. Figure 2, this is the direction of flow when it is activated for Heating or Cooling. When the brown wire is connected to L1, the blue wire connected to L2, and the black control wire is connected to G2S the valve is controlled by voltage at L2 and G2S. Voltage at G2S activates the valve for DHW. No voltage at G2S activates the valve for Heating/Cooling. See wiring diagram above. **In order to position the dhw actuator in the correct position. You will need to turn the dhw valve to match figure 2. Connect the wires as show above and place the actuator to the side next to the dhw valve. With dhw mode off IE: the unit is in heating or cooling only. Turn the cx35 on and let the unit run for a few seconds, the actuator may or may not move depending on how it was built at the factor and what origin point the stem is in, after about 2 mins of the unit running you may place the actuator on to the dhw valve and tighten down to its final position. Verify that the dhw and heating/cooling is working.**

If one or more V18b units are used they must be in front of the G2 Valve (upstream from G2) See V18b manual.

## G valves Continued

Note: the DHW valve is Straight thread, there will be 3 of these adapters per valve. This adapter adapts the straight thread to 1" npt.



When installing the actuator on to the valve consult the pictures below to make sure you have it oriented in the correct directions.

If your actuator matches Pos 1 then you will need to turn the DHW valve to match figure 1 on the previous page.

If you actuator matches Pos 2 then you will need to turn the DHW valve to match figure 2 on the previous page.

If the actuator is in any other orientation then install the DHW valve as shown in figure 2 on the previous page and then power up the Chiltrix and with the actuator connected electrically **BUT NOT ATTACHED TO THE VALVE**, make sure DHW is disabled. Once the compressor is running then place the actuator onto the DHW valve and test the unit for proper DHW function.

Pos 1



Pos 2



## G3 Valve: Seasonal Switch Valve

G1 and G3 valves use 220v Primary from the CX34. Use conduit and install per local code.

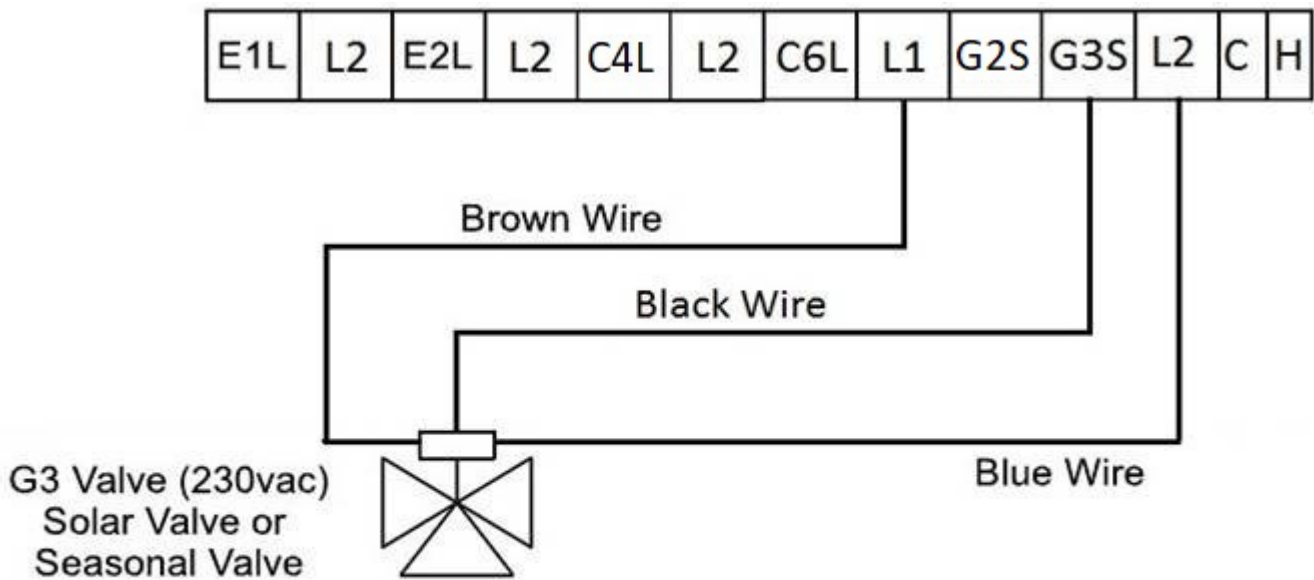

When Parameter P14 is 0, G3 is Configured as a Seasonal Switch

When Parameter P14 is 1, G3 is Configured as a SolarPre heat Valve

The G3 port can be used to control a seasonal switch valve. The seasonal switch valve is used to isolate the floor coils from the fan coils when switching over from heating to cooling. The seasonal switch valve is controlled by parameter P14. When parameter P14 is 0, the valve is configured as a seasonal Switch.

When parameter P14 is 1, the valve is configured as a solar pre-heat valve. The CX34 compares the solar tank temp and AC returned temp. When the solar tank temp – AC returned temp is  $\geq 5$  °C, the 3-way valve G3S will be on; when solar water tank temperature minus the air conditioning returned temperature is less than 2°C, G3S will be off.

# G3 VALVE Seasonal Switch Valve

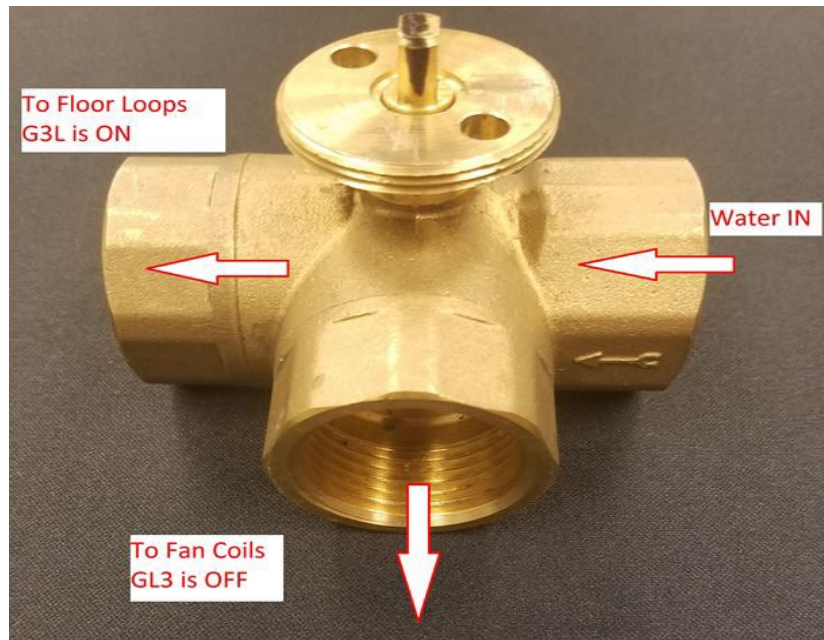
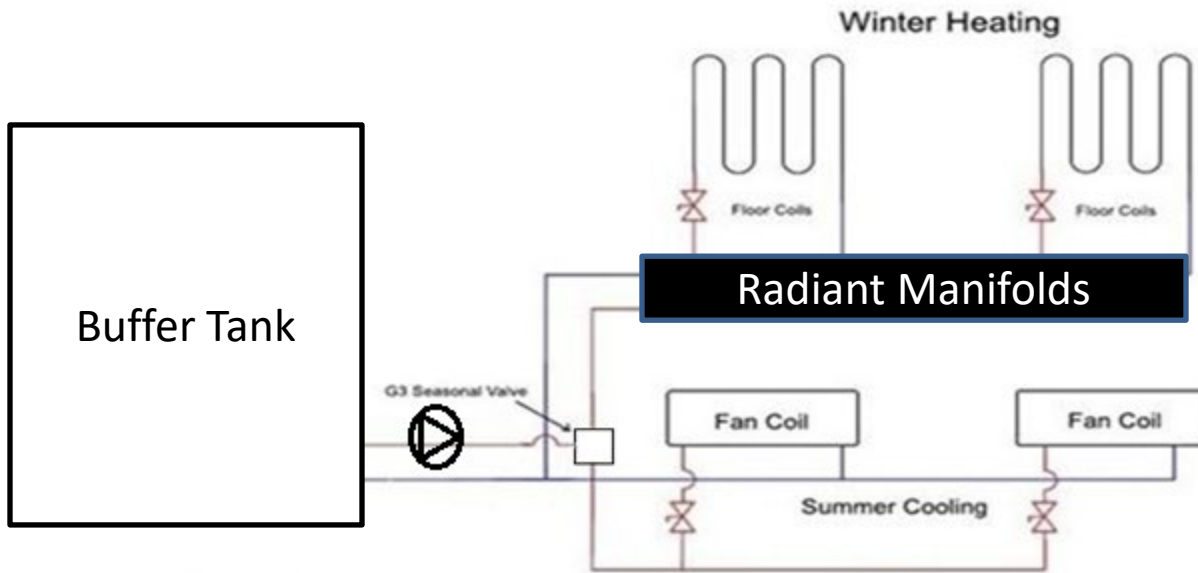

**G3 Ports**

## Second Heat Source

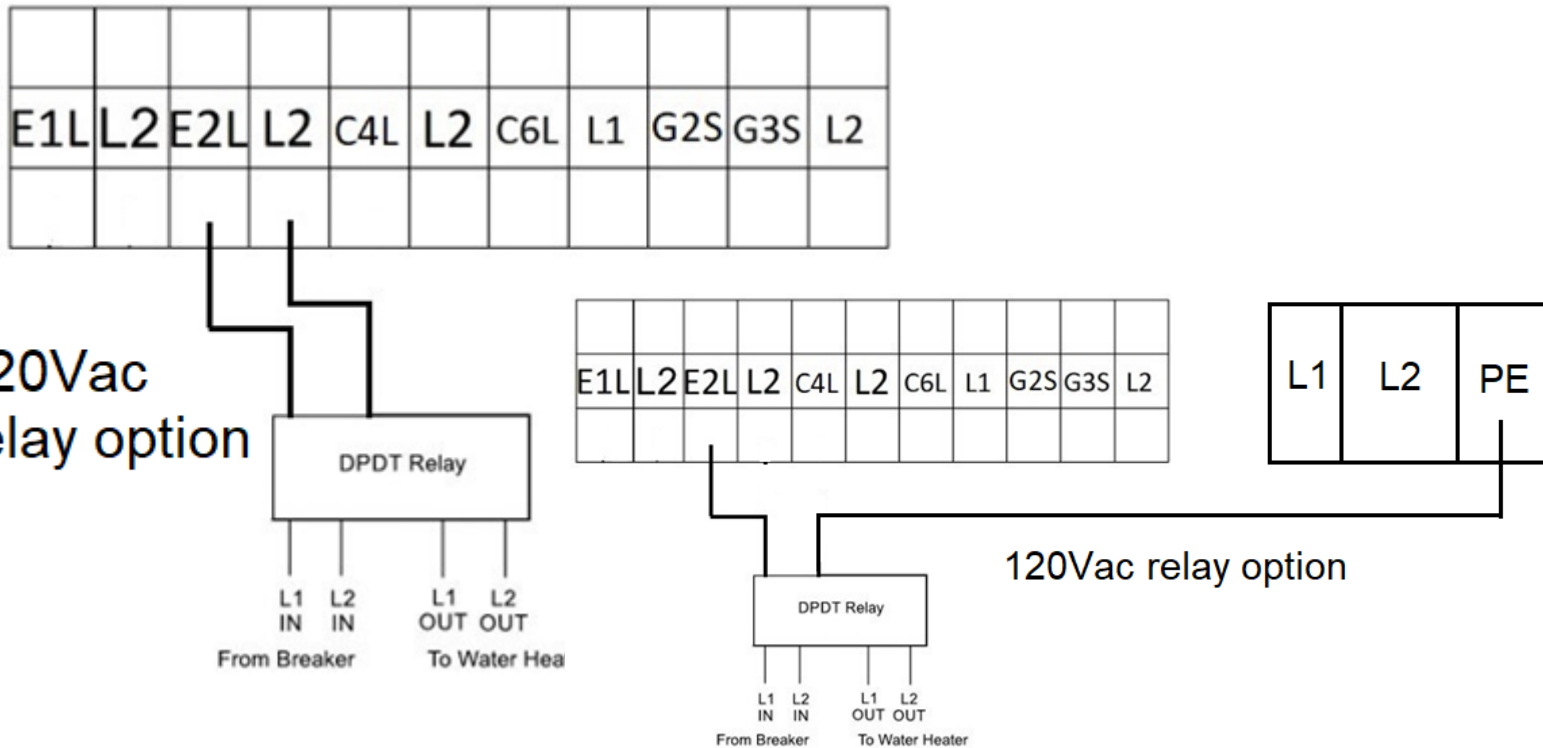

- This is used by customers that don't THERMOSTAT TO BE INSTALLED ON THE INLINE TANK USED FOR BACKUP HEATING. **DO NOT USE A BUFFER TANK FOR BACKUP HEATING. SEE CHILTRIX TANK MANUAL.** This would typically be a small inline tank located on the supply side of the loop, between the CX34 outlet and the first of any load inlets. The thermostat/element must be set to max 120F and any such tank used for this purpose must have code-compliant pressure relief valve installed and properly vented via copper pipe to a drain.
- NOTE- in the application the E@ backup heat only allows/denies power to the standard tank thermostat control. The tank thermostat controls the element.
- **NOTE\* THE PREFERRED WAY TO ADD BACKUP HEAT IS TO USE THE CHILTRIX V18 DYNAMIC VARIABLE BACKUP HEATER.** "SECOND HEAT SOURCE" IS AN OLDER AND MORE COMMON METHOD, BUT IS NOT AS EFFICIENT AS A V18.
- P10 is E2 activation air temperature. Outdoor air temp must less than P10 for E2 to be activated.
- P10 default is 0°C (P10 range is -20~20°C)
- P27 must be set to 0 for E2 to be enabled
- P84= the E2 start delay time. If compressor cannot meet target for X minutes (P84 minutes) then E2 will start.

## Onboard External Relay Control

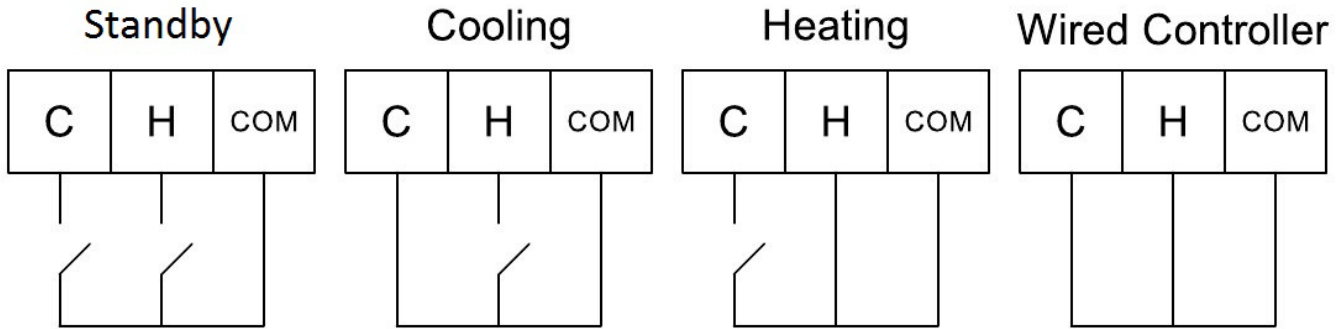

Above shows the C-H-COM terminals logic.

**IMPORTANT:** The C,H, Com terminals are DRY CONTACTS. Do NOT apply Voltage to the terminals.

This optional feature allows you to control the mode (heating or cooling, standby) of the Chiltrix heat pump from a standard single stage heat pump thermostat. There are two options explained below, with instructions, drawings and configuration settings on the next page.

### Option 1 (This is the one that's most commonly used)

With this option, a standard single stage heat pump thermostat can be used to select the cool-heat-off (standby) mode of the heat pump. When the thermostat makes a call for heating or cooling the compressor starts with the reversing valve in the correct position, according to the mode you have set on the thermostat, and will target the user-defined preset tank target temperature. Note, this option does not maintain a temperature in a buffer tank between calls so the tank temperature may drift from target if it has been a significant amount of time since the last call. However, after a short thermal lag the target tank temperature will be restored.

### Option 2

This option leaves the heat pump in its last used operating mode, the heat pump continuously monitors the buffer tank temperature, running the compressor at a variable speed to replace any standby losses as they occur, maintaining the tank at the target temperature. With this mode, the thermostat selector can only chose heating or cooling. To turn the system off, you would select off at the thermostat and then also use the Chiltrix controller to stop the heat pump. This option eliminates any thermal lag caused by standby losses.

Either of the above options allow a standard single stage heat pump thermostat or other external controller to control switching the heating, cooling (and it option 1, standby) modes of the heat pump via relay. This method of control generally requires a single-stage standard heat pump thermostat, a installer provided 24 vac transformer and two relays, (Eg. Tyco K10P-11A15-24, w/ two relay sockets, 27E487). The relays can be located in the chiller next to the IPM. The transformer can be located in the home near the standard thermostat or other controller.

## Onboard External Relay/T-Stat Control

**NOTE:** Before removing any jumper or connecting any relays, make sure of the following:

1. Enable/disable DHW, as applicable, at P08. Your selection will follow along with a change between heating and cooling. If DHW is active (Parameter P56=1) DHW will work even when external relay control has the system "off" (standby).
2. Use the controller Mode button to switch modes and set the target temperatures of each mode Heat, Cool and DHW, before proceeding.
3. Auto-switchover (based on outdoor temp) at P45/P46 cannot be used when using this feature.

**IMPORTANT:** The C,H, Com terminals are DRY CONTACTS. Do NOT apply Voltage to the terminals.

### OPTION 1 (NO Relays)

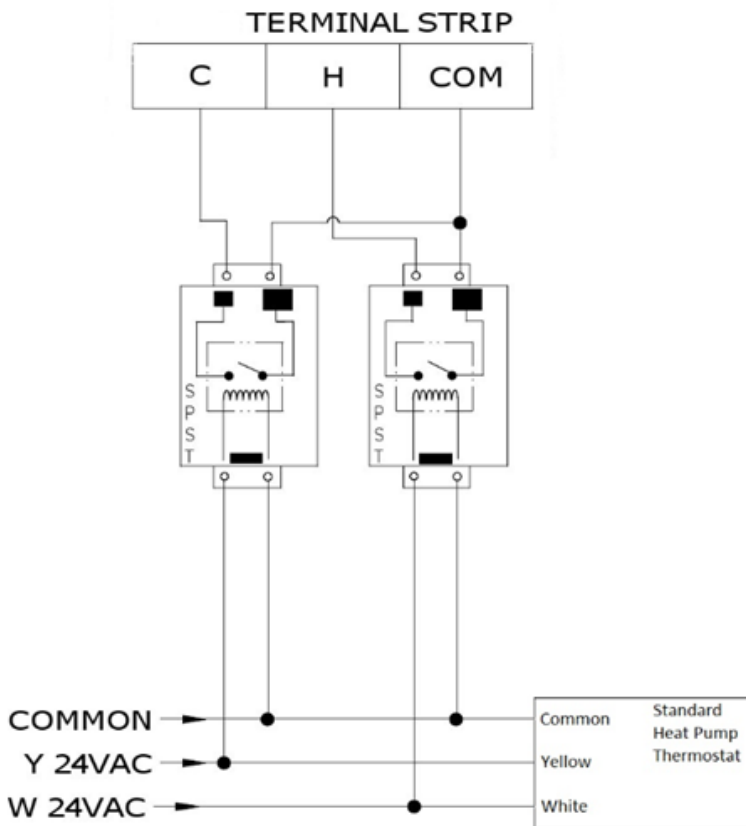

### OPTION 2 (NC Relays)

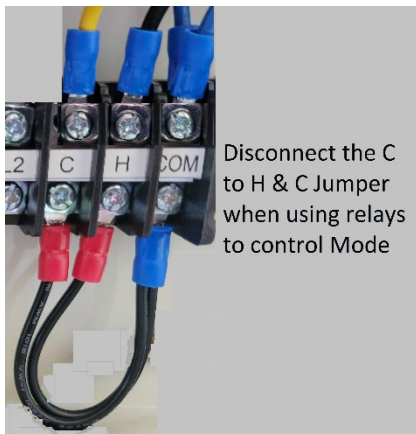
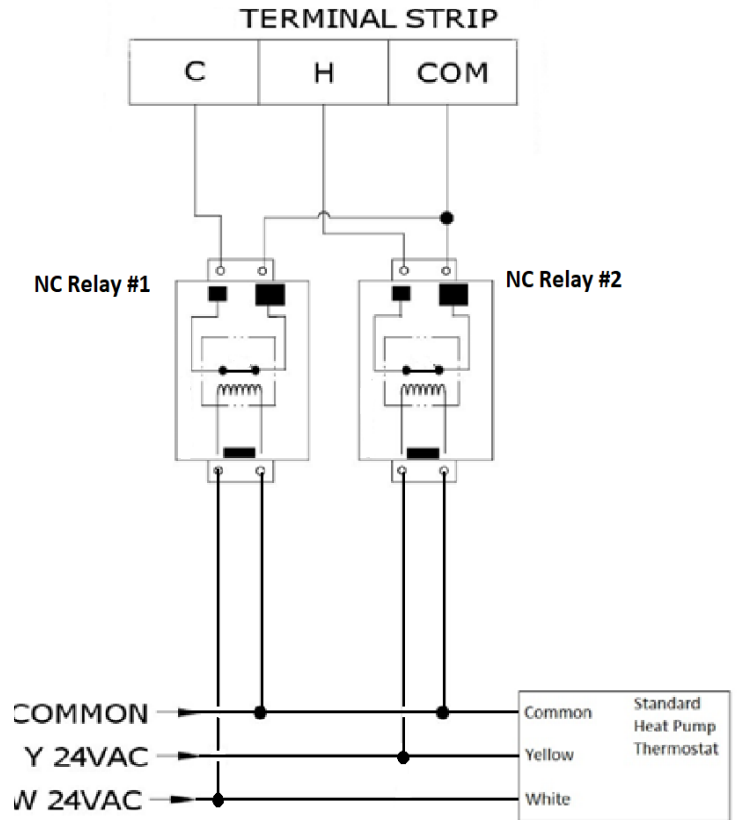

The switch status can be displayed in the C parameters  
 C7 is AC heating switch mode status; 0=OPEN; 1=CLOSE  
 C8 is AC cooling switch mode status; 0=OPEN; 1=CLOSE

**NOTE:** Using this relay control option will NOT override inputs from the Chiltrix standard wired controller unless p111 is enabled. See the Psychrologix manual for important additional information if this applies to you. Timers as explained elsewhere in this manual will NOT be available when relay control is used.

## System filling with Propylene Glycol and water

At or near the cx35 a flush/fill valve assembly must be installed. This can be made with three ball valves and a couple hose fittings. If you don't already have a fill kit for use with solar thermal, hydronic, or chiller systems, you can easily create one with the following Bill of materials: All Pex fittings are available at [www.supplyhouse.com](http://www.supplyhouse.com)

2 ea. Pex 1" x 3/4" Tee SKU: H051175LF Brand: Rifeng

1 ea. Pex 1" Ball Valve SKU: H081000LF Brand: Rifeng

2 ea. Pex 3/4" Ball Valve SKU: H080750LF Brand: Rifeng

2 ea. 3/4" Hose Fitting SKU: G20103 Brand: Jones Stephens

2 ea. Pex 3/4" x 3/4" NPT Female Adaptor SKU: H040750LF Brand: Rifeng

10' of Garden Hose Home Depot

5 Gallon Bucket Home Depot

High Head Fill Pump Grainger

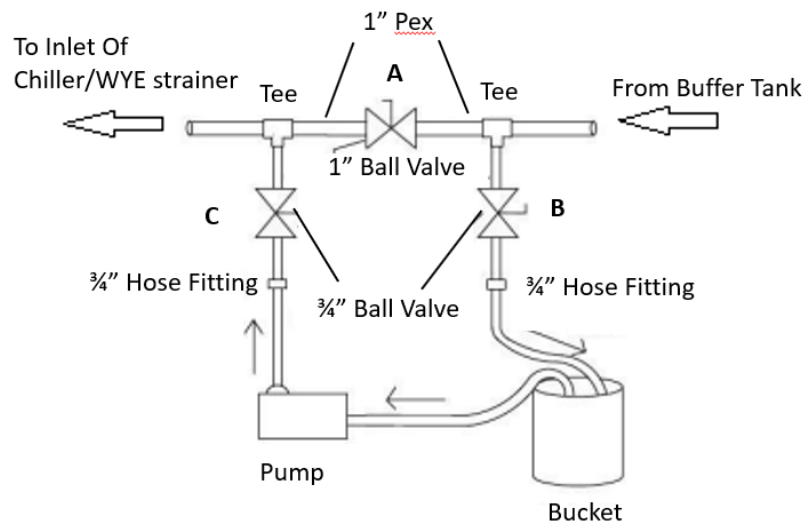

Pre-mix the propylene glycol in a container large enough to hold the loop volume plus a few gallons. Using a filling pump and 3 hoses, place one hose in the glycol container and connect it to the suction side of the pump. Connect the second hose to the pump discharge and the other end to valve "C". Using a third hose, connect it to valve "B", and leave the open end in the glycol bucket. Close the middle ball valve "A". Close the middle ball valve "A". The pump should be pumping toward the Cx35 chiller. Open and close valve "A" a few times to remove trapped air.

Run the pump until there are no more air bubbles coming out of the loop. After all air is expelled from the loop, close valve "B" and then open valve "A" with the pump running. When the pressure gage on the cx35 shows at least 30 psi close valve "C" and turn off the pump. Minimum loop pressure is 14.5 psi, maximum pressure is 43.5 psi, and ideal pressure is 20-30 psi.

See more info on Isolation valves used with the flush fill system here  
<https://www.chiltrix.com/documents/Charging-Fill-Kit.pdf>

**System filling with Propylene Glycol and water**

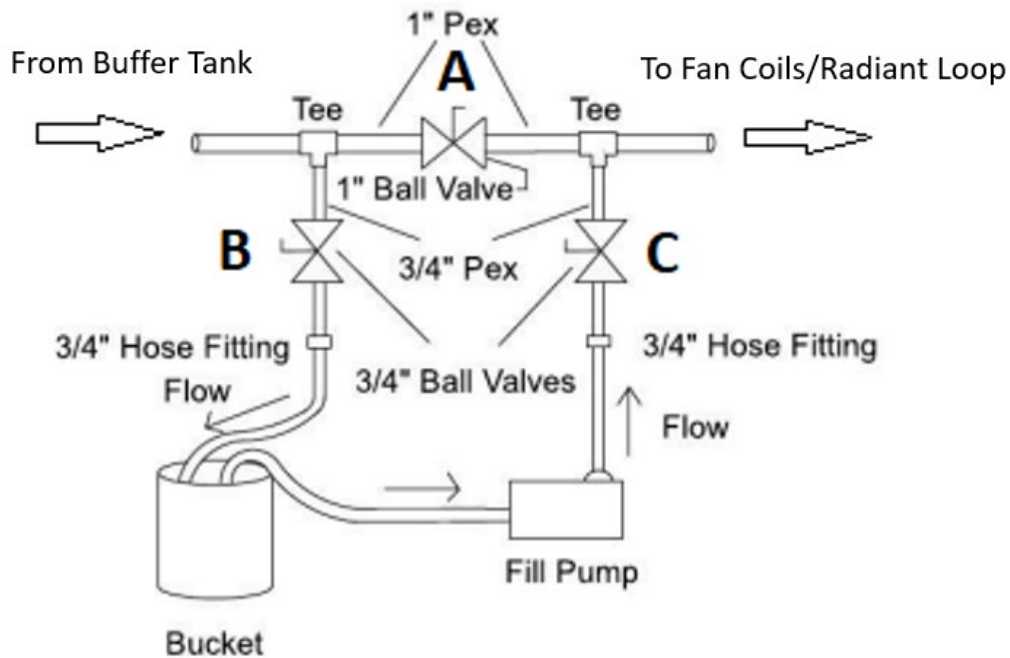

On complex or large load-side systems or load-side systems dealing with fan coils on an upper floor, there may be a need for a flush fill kit on the load side of the buffer tank. The diagram/parts lists is the same as the approach for the supply-side. The only difference is that you will be pumping from the bucket to the fan coils/radiant and through the buffer tank.

See more info on Isolation valves used with the flush fill system here  
<https://www.chiltrix.com/documents/Charging-Fill-Kit.pdf>

## Purging Air From DHW Tank & Fan Coils

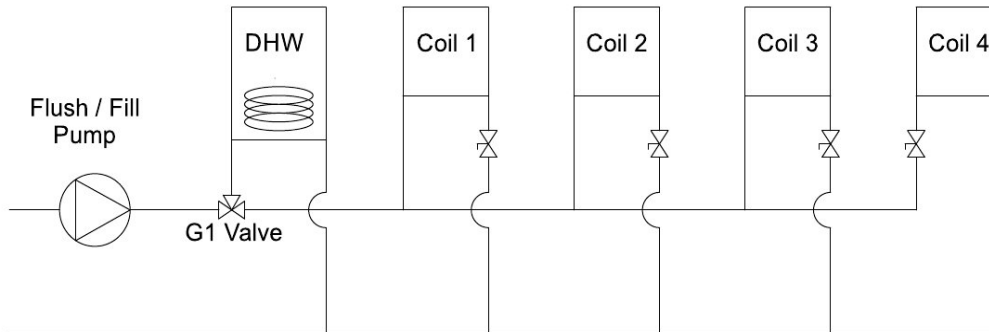

If a DHW tank is installed, it should be the first device on the loop as shown. The G1 valves should always be as close to the CX34 as possible. The tank should be as close to the G1 valve as possible.

To purge the air from its coil, remove the actuator from the valve body and rotate the valve stub 90° clockwise to force the water through the coil. Return the valve stub back to its original position when all of the air is purged. Close the input valve to each fan coil except the first coil (1). Turn the pump on and run it, when the bubbles stop coming out of the discharge hose turn on the ball valve on coil (2), wait for the bubbles to stop, then do the same for coil number (3), then (4). All CX Chillers have a flow switch installed in the loop. Air in the system may cause a flow switch alarm; the controller will display a P05 error code.

All CXI fan coils have an air purge screw near the water inlet port, always purge the fan coils before starting the chiller. The CX34 chiller also has a bleeder valve with a ¼" clear tube attached to it located near the brazed plate heat exchanger.

### Fan Coil Flow Balancing (Performed at time of commissioning)

Proper and even flow through each fan coil is important for both heating and cooling. (Coil temperature can be displayed by pressing the up and down temperature arrow keys at the same time), This can be done with balancing valves or ball valves installed at each fan coil supply or return pipe. This must be done with the CX34 in heating mode, set loop AC target to the maximum temp setting for commissioning.

**DO NOT DO THIS IN COOLING MODE OR DAMAGE MAY OCCUR.**

Adjust valve positions until each fan coil has the same leaving fluid temperature, with all CXIs set to max manual fan speed and in heating mode. When all leaving fluid temps are the same, the units are properly balanced. If a fan coil is powered on but the fan isn't running, there is a good possibility that there is air trapped in that particular part of the loop. Also verify the parameters with the CXI FCU manual, page 34. <http://www.chiltrix.com/documents/Chiltrix-hydronic-FCU-ver-1.5.pdf>

Note – while only one ball valve per CXI is needed for balancing, best-practice would be to use 2 valves, one on supply and one on return, so that the fan coil unit could be isolated if needed.

### Standard Controller (Included with all CX34 Units)

**Cooling, Heating, DHW, cooling + DHW, heating + DHW mode of operation options, automatic fault detection, alarm processing, and energy control.**

1. The 4-conductor control cable can be extended up to 300 feet of 20 AWG or larger.
2. The controller handles all input and output signals, and system status.
3. Full-touch color LCD display. **MUST BE INSTALLED INDOORS.**
4. Modes, set points and other factory parameter settings are entered directly on the LCD screen. Note, for heating and cooling, the set target refers to the return water temperature, in steady-state operation, the leaving temper will be +/- 5C (9F). The normal cooling set target is 53F which implies a leaving steady-state temperature of 44F. Heating, for radiant, is normally set for 86F (implies leaving at 95F). Heating, for fan coils, is normally set at 96F (implies steady-state temp of 104F). The CX34 can achieve a leaving temp of 131F under most but not all conditions. The maximum supported target set point is 111F (implies a 120F leaving temp).
5. 100 fault records can be stored and retrieved to show the details of each fault that may occur.
6. All of the switch input / outputs can be directly observed on the LCD control panel making commissioning convenient.
7. The LCD display is wall-mountable.

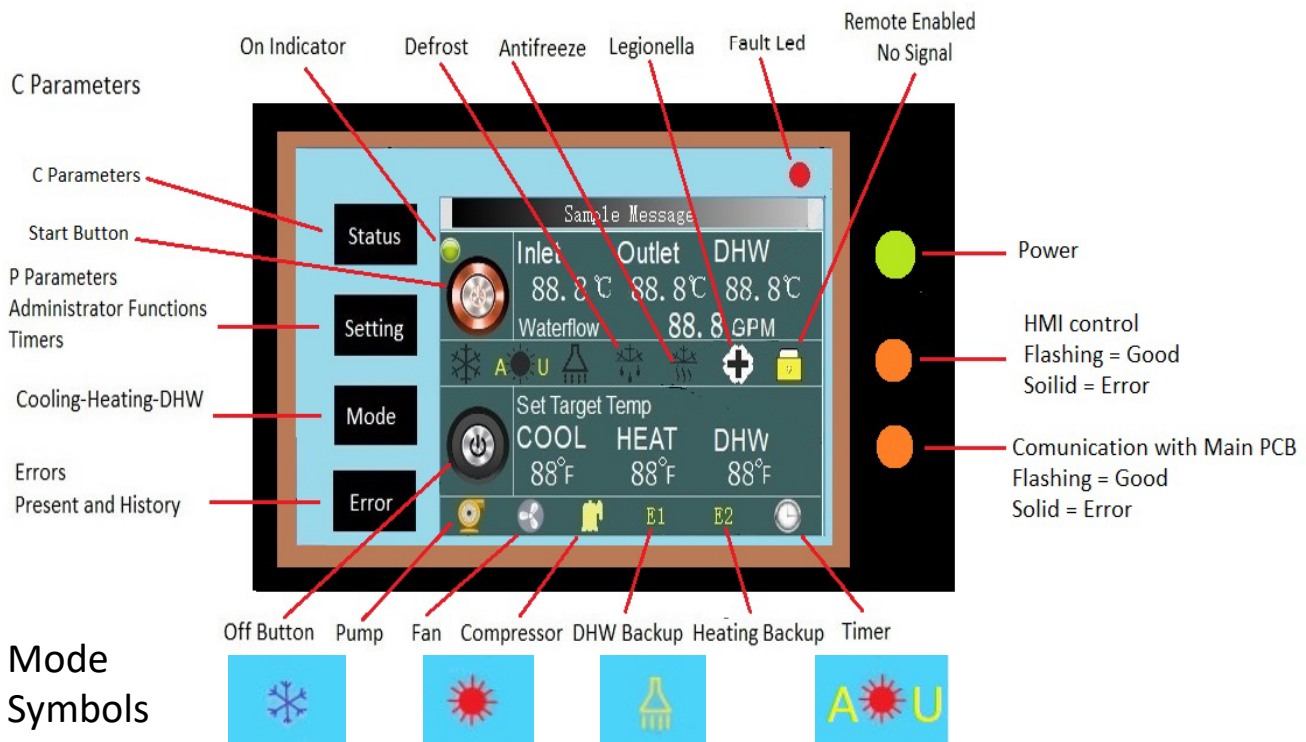

- Mode Symbols**
- Cooling
  - Heating
  - DHW
  - Heating with AU
- (1) **Taskbar:** shows the current running applications, and the time. Clicking on the different application boxes will switch to different applications.
  - (2) **Main window:** Displays the main window of the application that is currently running.
  - (3) **Application icon:** A desktop application that first highlights the icon when it is first clicked, and then clicked again to launch the application.

**Indoor Controller!**  
**This controller must be installed indoors.**

## CX34 Desktop

### Settings:

Chiltrix heat pump setting for space heating/cooling are always set for return temperature, with a steady-state leaving temperature +/- 9F

### Standard Settings:

Space cooling: 54F (note, this implies a leaving temperature of 44F)

Space heating: For Chiltrix supplier AHU/FCU 96F (Note this implies a 105F leaving temperature. Max recommended temp 111F (120F leaving temperature

DHW: Max 120F

### Keys Operation

#### Status

Click "Status" at the home page to enter the "C" parameter checking page as shown below. Click the arrow ">" button to go to next page.

Item	Value
C00 Coil temp	888.8 °C
C01 Compressor discharge temp(AIN1)	888.8 °C
C02 Ambient temp	888.8 °C
C03 HP AC outlet water temp	888.8 °C
C04 DHW tank temp	888.8 °C

Navigation: < 1/15 >

Click **“Setting”** button, and you will enter the system setting page. Then you select the language, set time and Administrator settings.

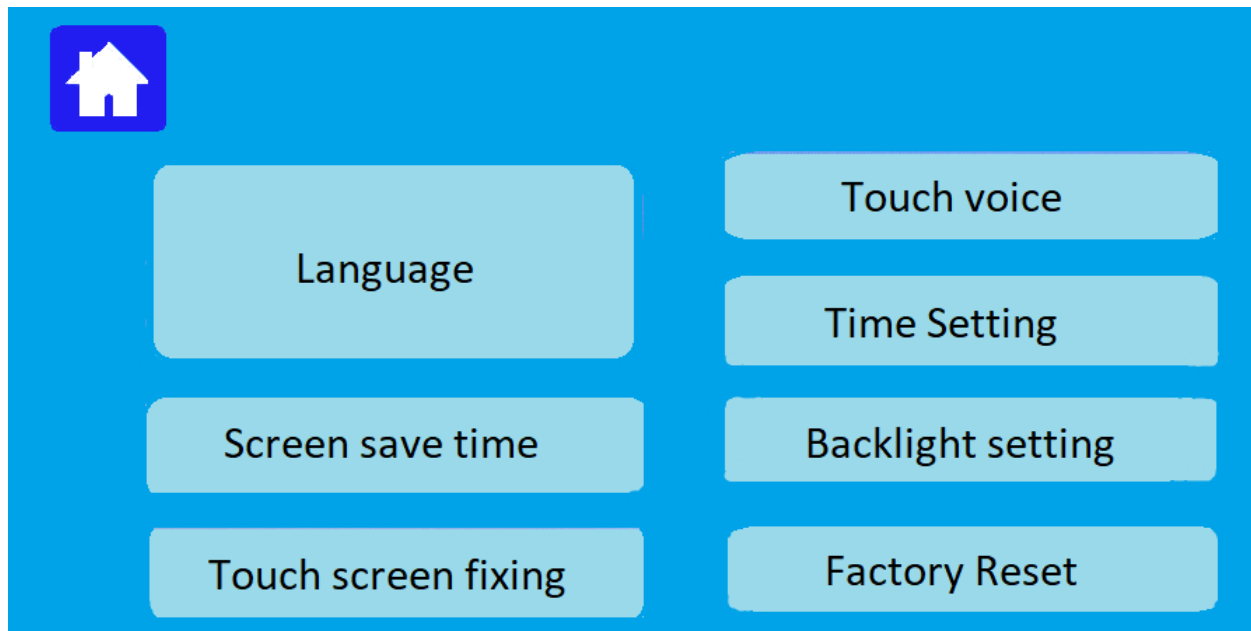
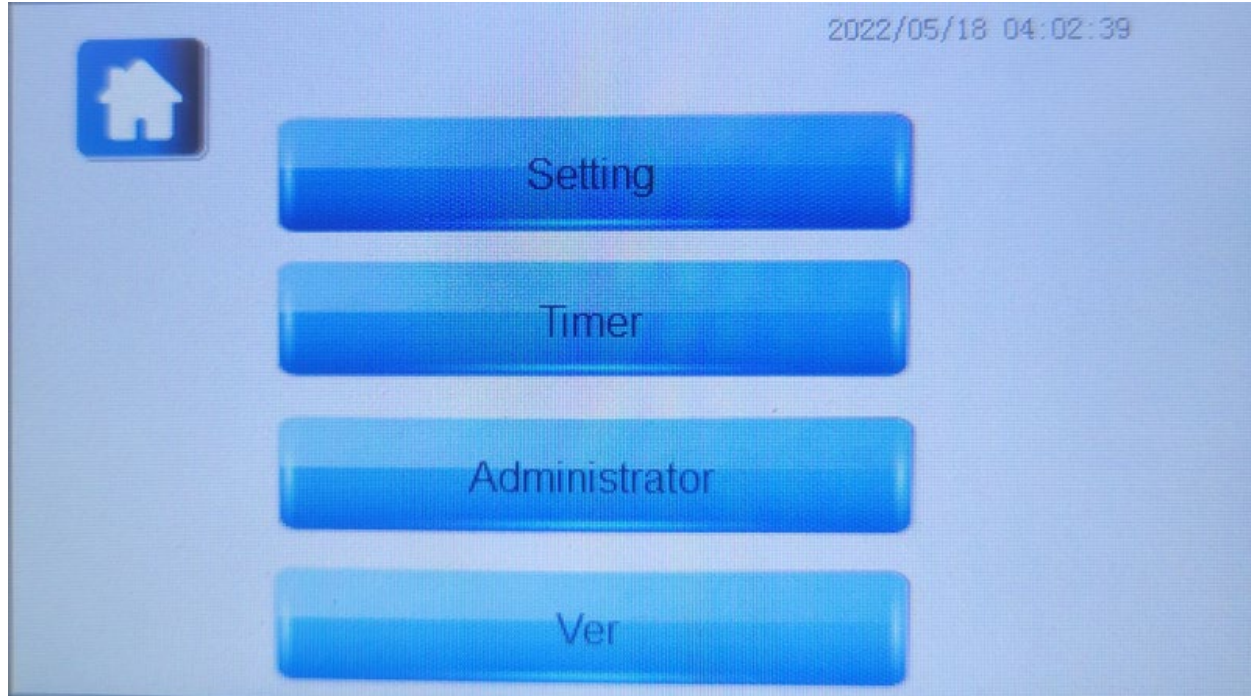

Settings Menu

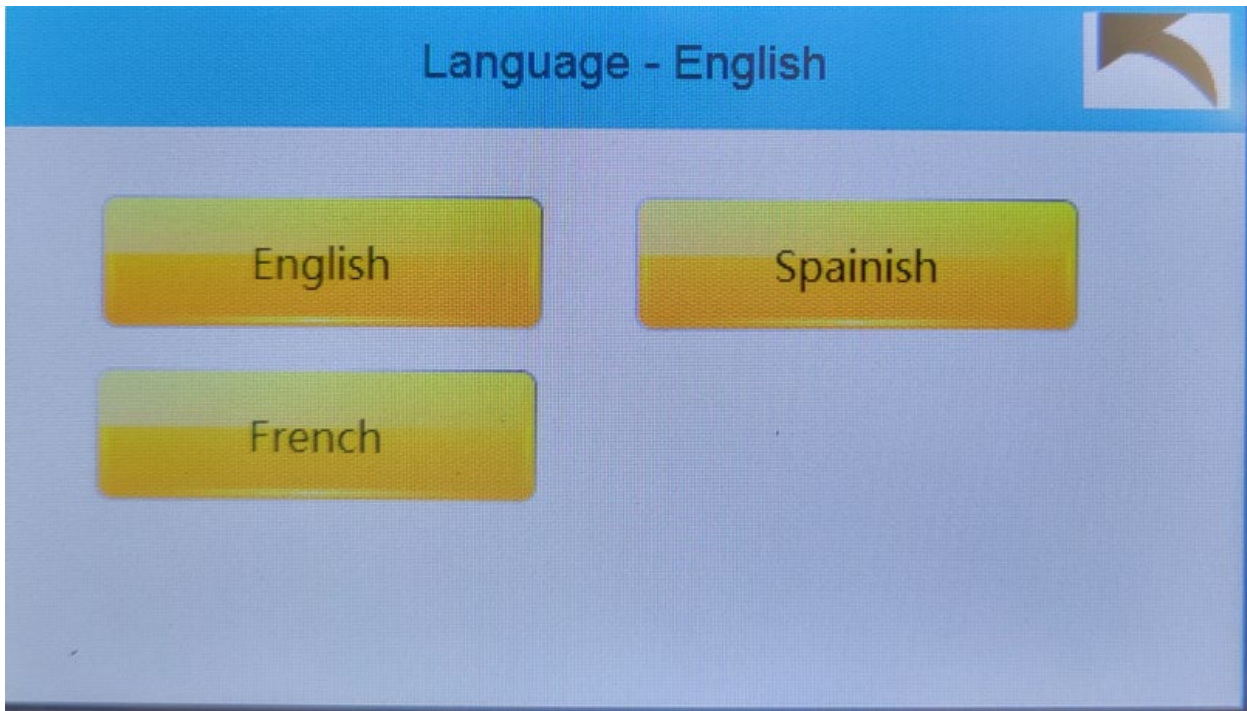

Language Screen

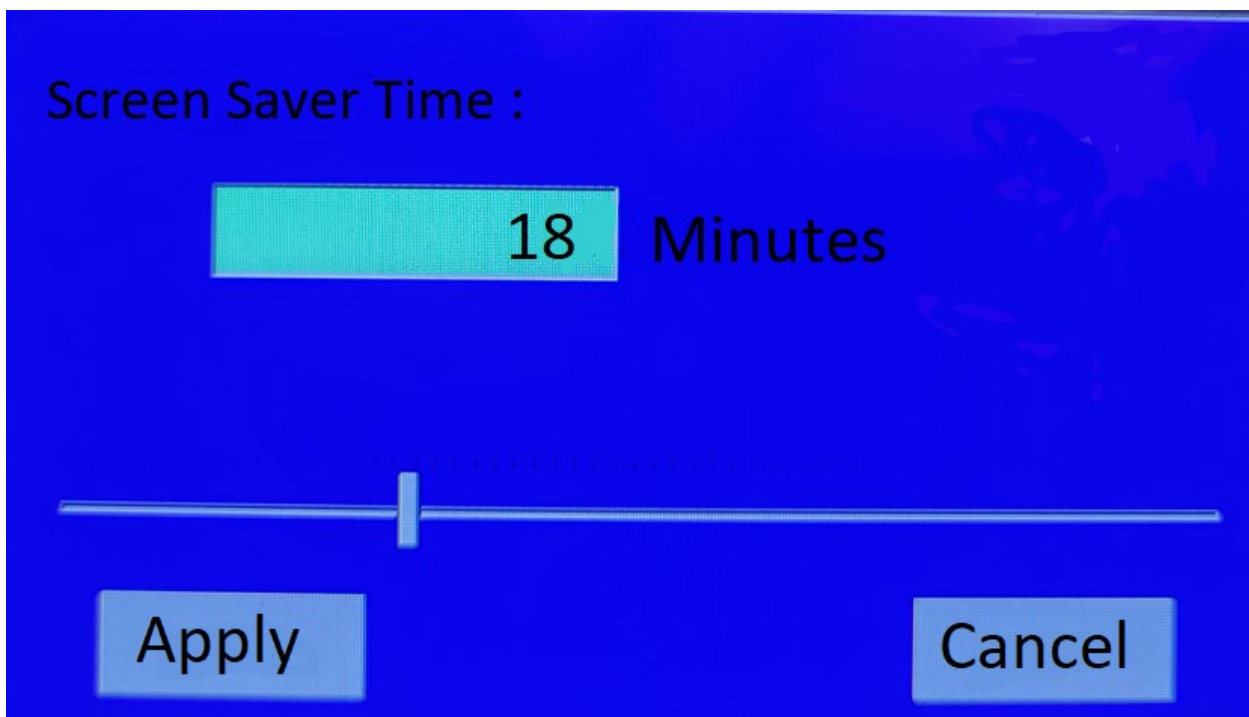

Screen Saver

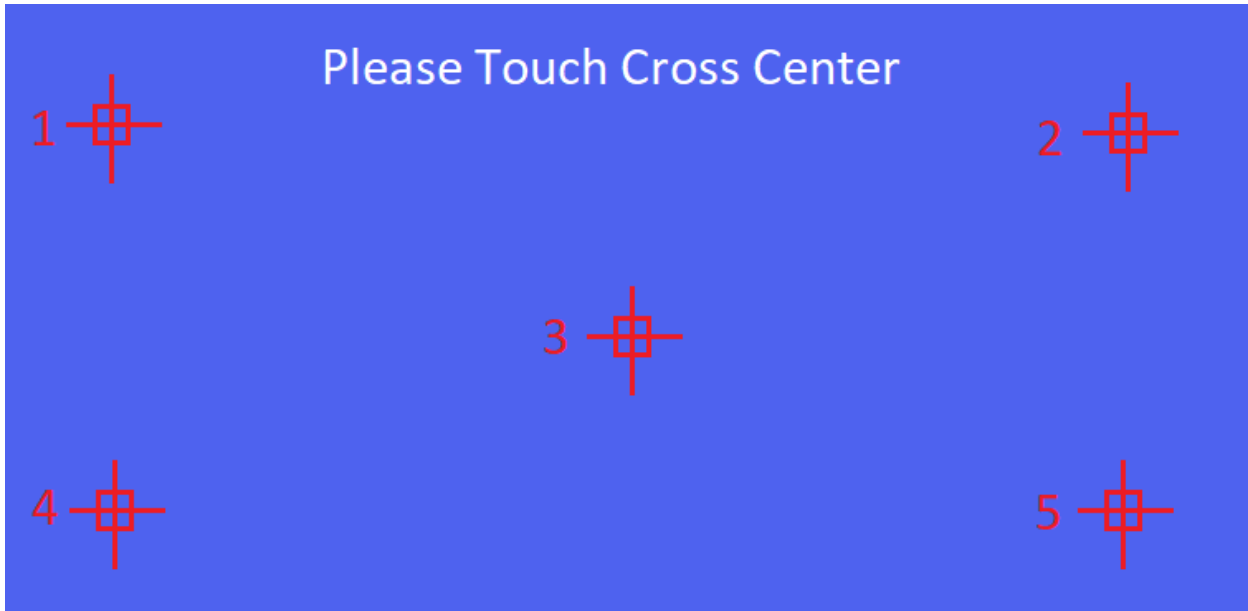

Touch Screen Fixing (Calibration)



Time Setting

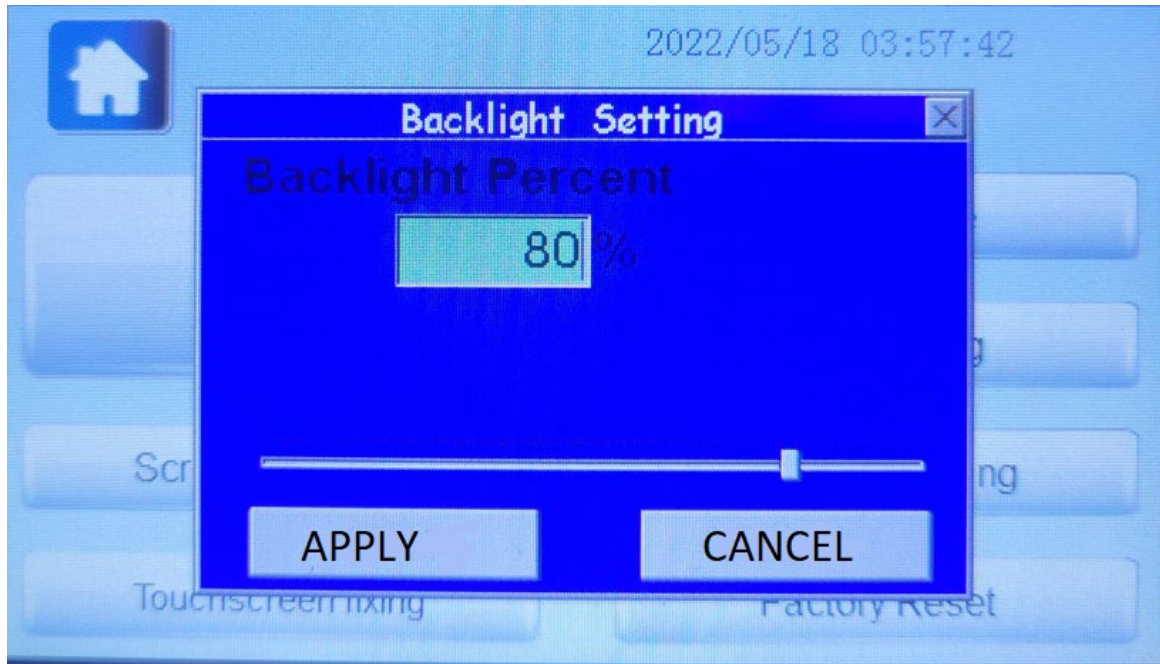

Back Light Setting

## Timer Function

Click “**Timer**” button, you can set the heat pump to turn on and off times, you can select different working modes for different time periods. There are total 4 periods, (8 points), in the timer setting.

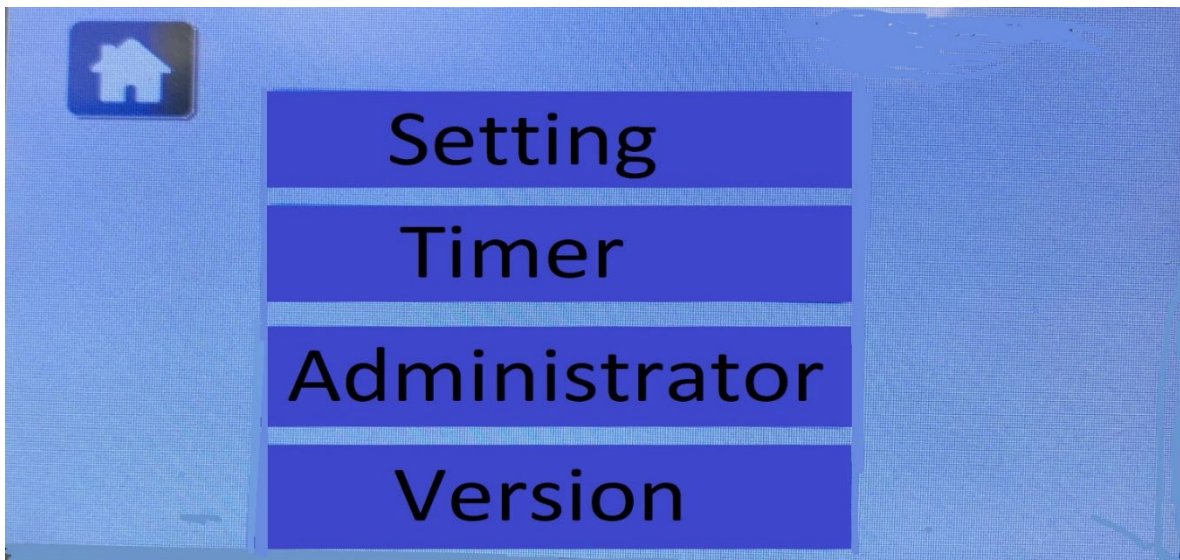

Press Timer to access the timer functions

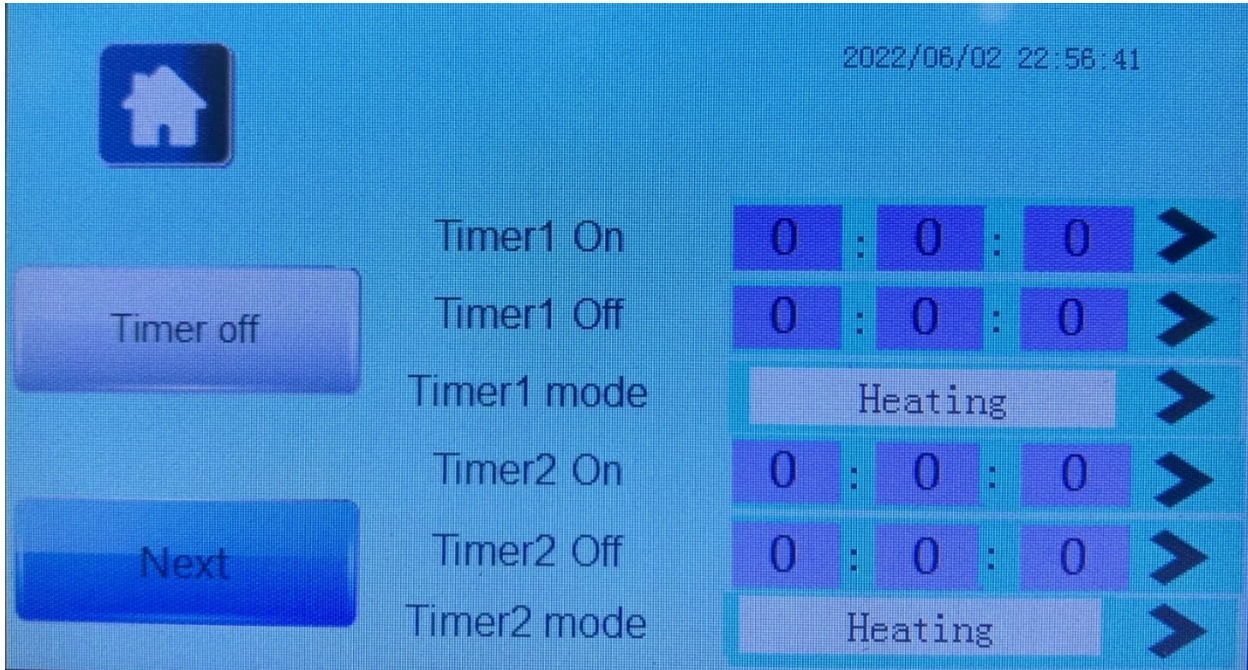

Timers 1 and 2 set to Heating Mode with no times set

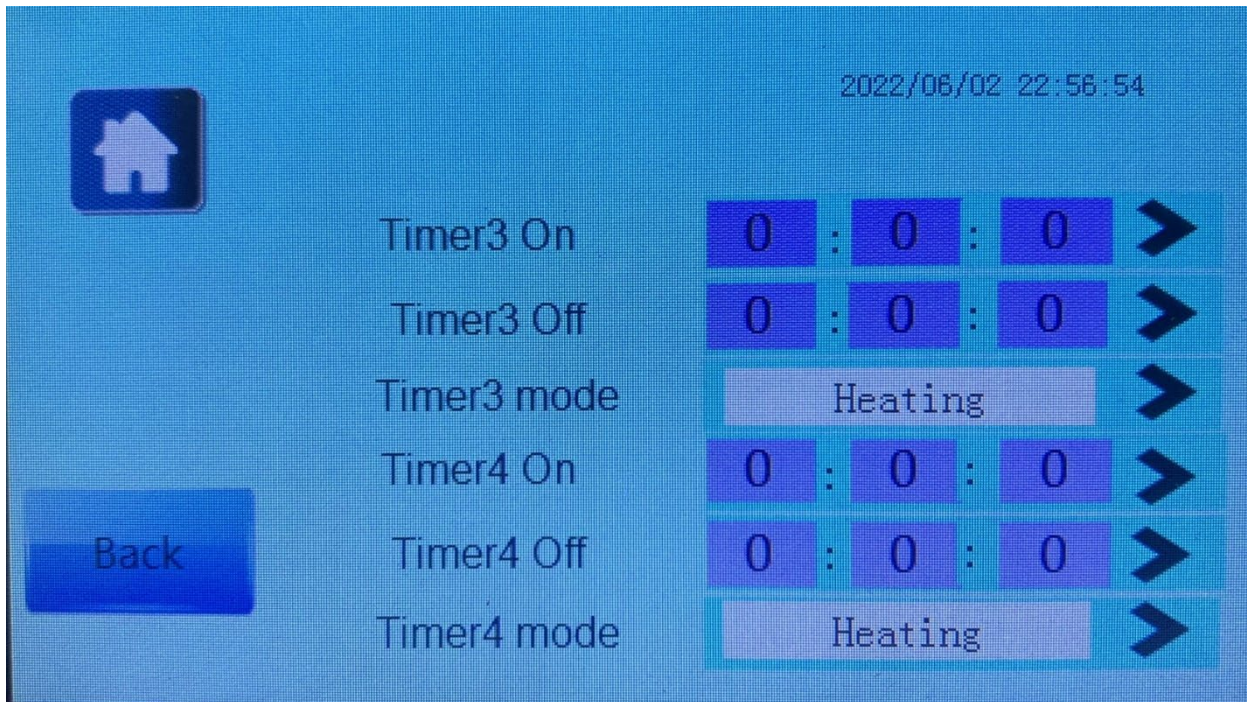

Timers 3 and 4 set to Heating mode with no times set

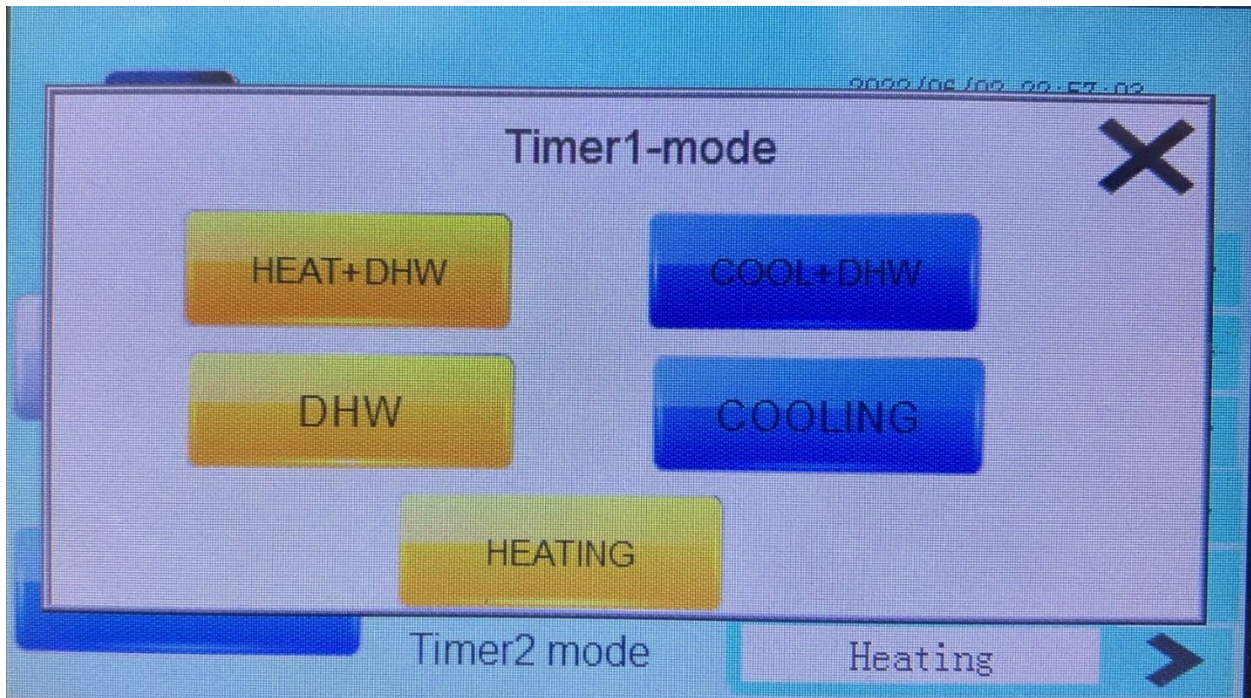

Setting the mode for timer 1, same menu for timers 1-4

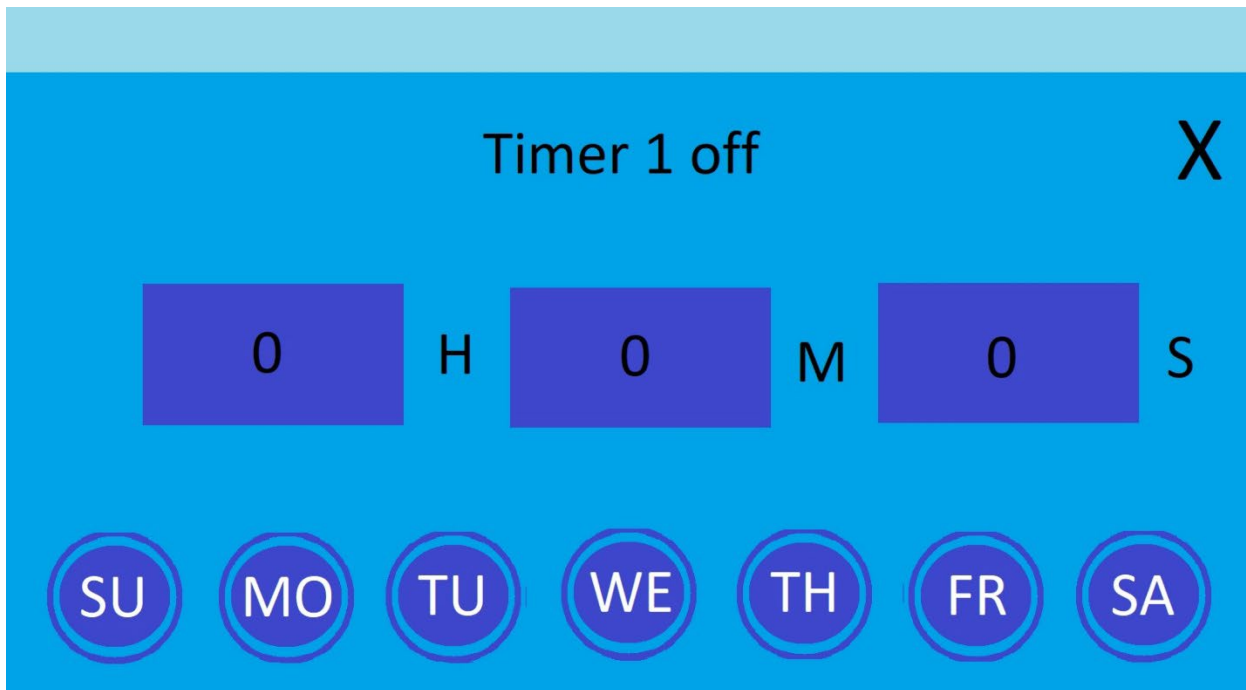

Timer 1 turned off, timers 1-4 use the same menu

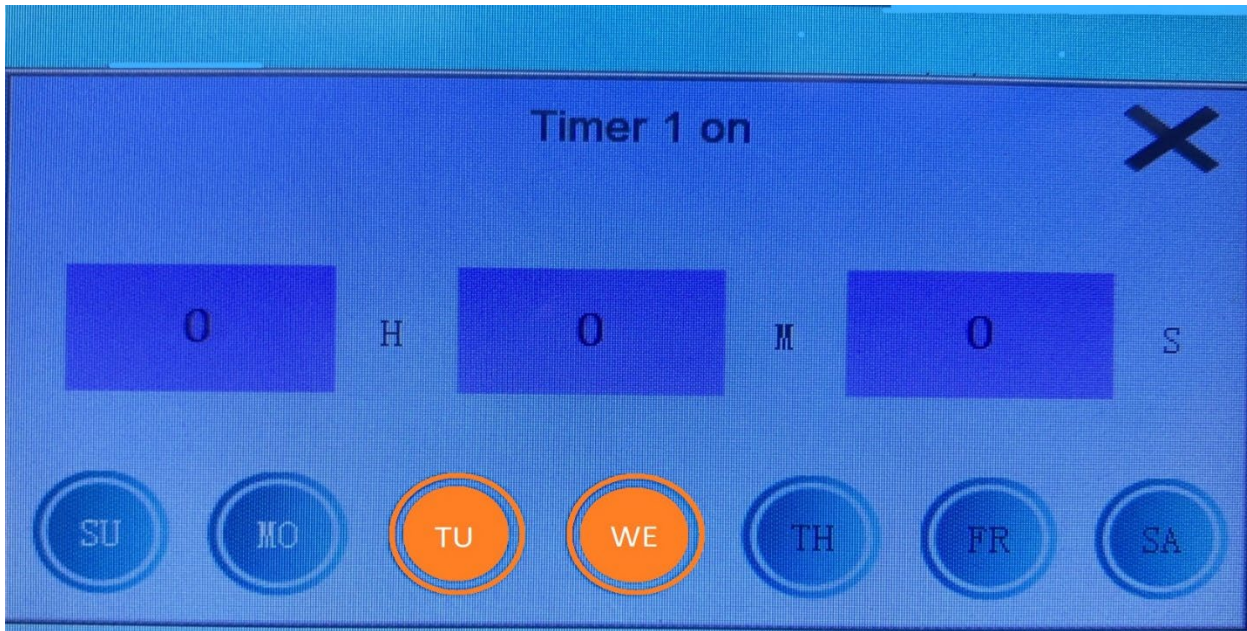

Timer 1 Start time and Days of the week selected (TU and WE), timers 1-4 use the same menu

### Administrator Functions

Click **“Administrator”** button, you need to enter the password **“2222”** to enter the **“P”** parameters setting page as shown below. Refer to **“P”** parameter section for parameter list. Example below.

Item	Value
P00 Auto restart after power off	1. recovery
P01 DHW hot water temp hystersis temp	88 °C
P02 AC temp hystersis temp	88 °C
P03 Coil copper pipe temp to active defrost	888 °C
P04 Water source side anti freeze temp	888 °C

1/22

**NOTE:** Any changes to P59 or P61 require a 15-second reboot at the circuit breaker panel or Disconnect

## Mode

Click “Mode” at homepage, you will enter mode selection page. To select the desired mode, press the corresponding button.

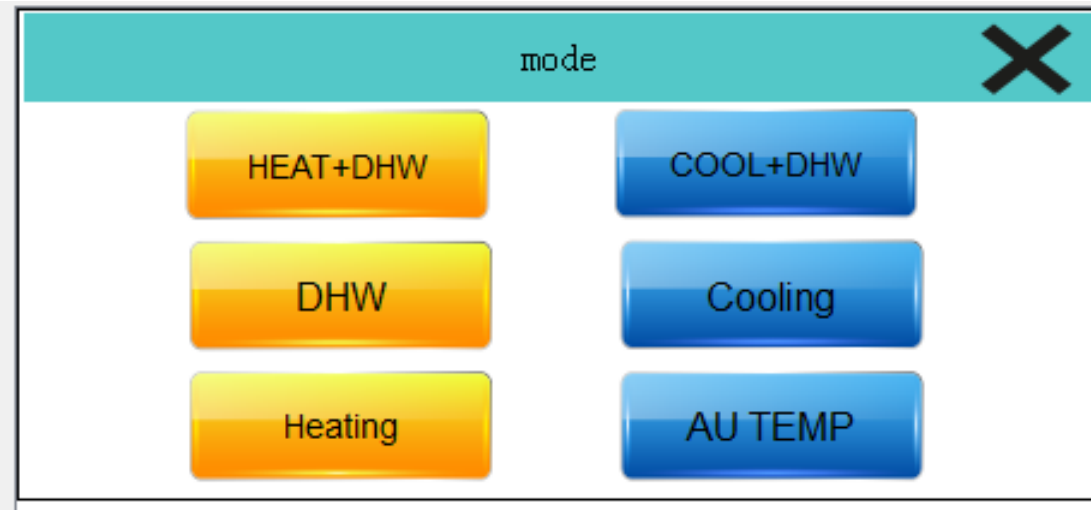

There are 5 standard modes available with DHW enabled, plus an AU Setting.

## **Auto Heating Target Curve Function**

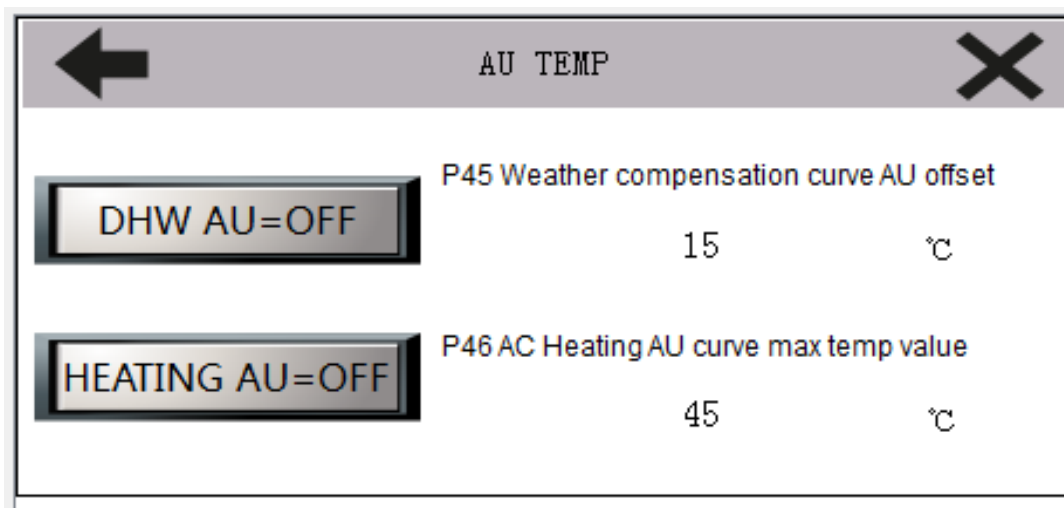

## Error Log

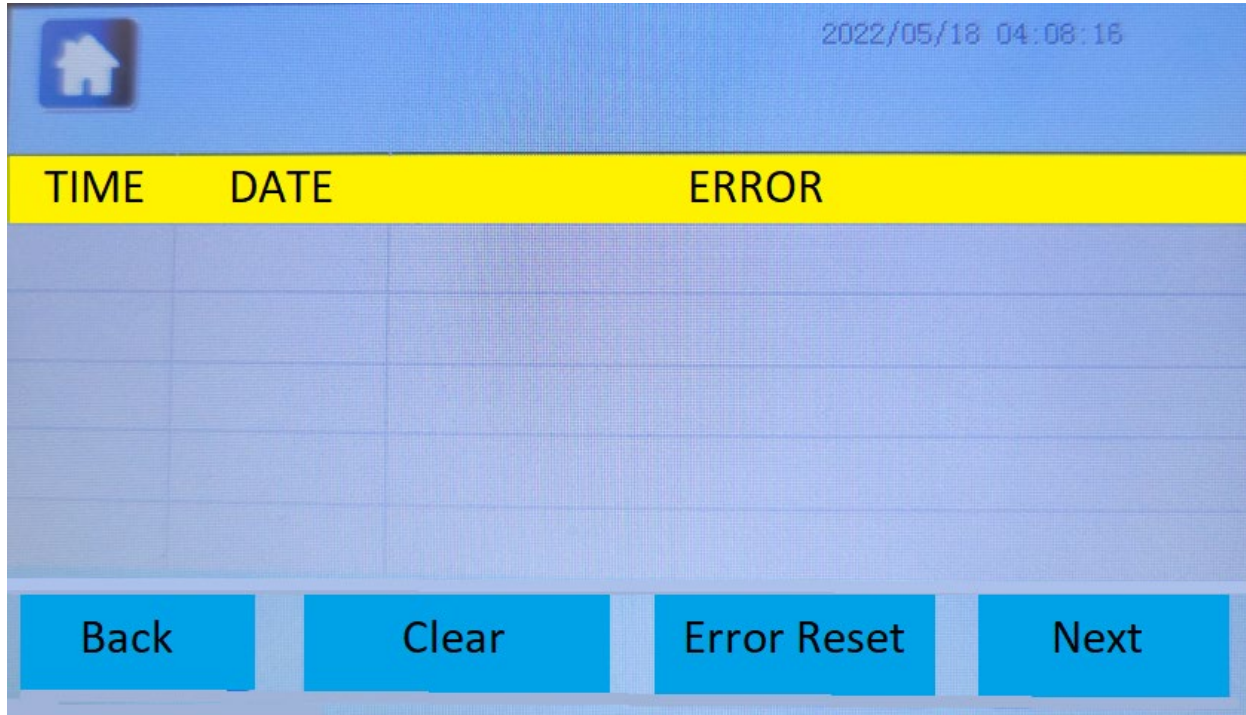

2022/05/18 04:08:16

TIME	DATE	ERROR

Back Clear Error Reset Next

Error Log above shown with no errors

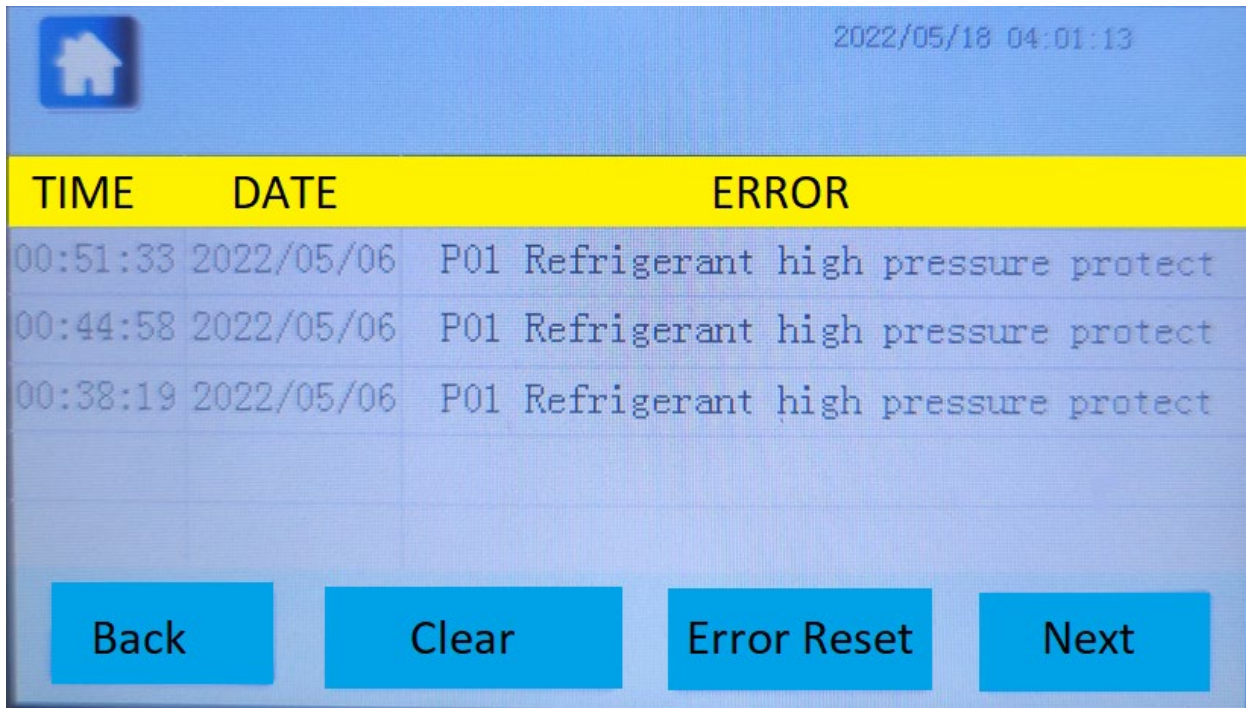

2022/05/18 04:01:13

TIME	DATE	ERROR
00:51:33	2022/05/06	P01 Refrigerant high pressure protect
00:44:58	2022/05/06	P01 Refrigerant high pressure protect
00:38:19	2022/05/06	P01 Refrigerant high pressure protect

Back Clear Error Reset Next

Error Log above shown with sample errors

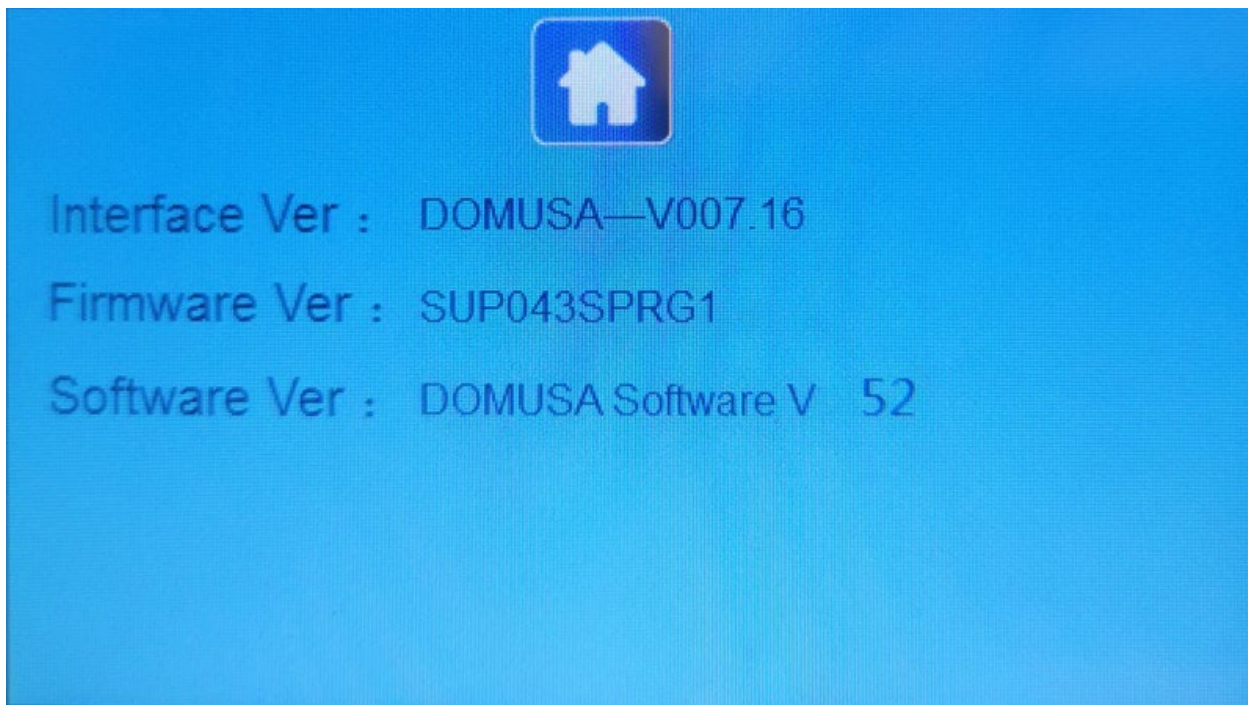

### Software Versions

The following pages contain the (LCD) C-Parameters, P-Parameters, and Error Codes.

To access the C-Parameters (read only), touch the “STATUS” button from the desktop.

To access the P-Parameters touch the “SETTINGS” button from the desk top.

To access the Error Codes touch the “ERROR” button from the desktop.

#### **Supported Settings:**

**Space cooling: 54F (note, this implies a leaving temperature of 44F)**

**Space heating: For Chiltrix supplier AHU/FCU 96F (Note this implies a 105F leaving temperature. Max recommended temp 111F (120F leaving temperature**

**DHW: Max 120F**

## C-Parameters Read-Only

LCD No.	Name	Range
0	Coil Temp	-30~97°C
1	Exhaust Temp	-30~97°C
2	Ambient Temp	-30~97°C
3	AC Outlet Water Temp	-30~97°C
4	DHW Tank Temp	-30~97°C
5	Solar Temp	-30~97°C
6	DIN9 Status (N/A)	0 (connect) ; 1 (disconnect)
7	DIN6 Status (Cooling Switch)	1 (connect) ; 0 (disconnect)
8	DIN5 Status (Heating Switch)	1 (connect) ; 0 (disconnect)
9	Sterilization Status	1 (sterilization) ; 0 (normal)
10	High Pressure Switch Status	0 (connect) ; 1 (disconnect)
11	2nd High Pressure Switch Status	0 (connect) ; 1 (disconnect)
12	Low Pressure Switch Status	0 (connect) ; 1 (disconnect)
13	Inside Water Switch	0 (connect) ; 1 (disconnect)
14	GEO Water Flow Switch	0 (connect) ; 1 (disconnect)
15	Compressor Overcurrent Protect Switch Status	0 (connect) ; 1 (disconnect)
16	Defrost	0 (Off); 1 (On)
17	AC Antifreeze	0 (Off); 1 (On)
18	DHW Antifreeze	0 (Off); 1 (On)
19	Compressor Running Frequency	Inverter: comp Speed.
20	ASHP Outdoor Fan/ GEO HP Water Source Pump	1: running; 0: Stop
21	Compressor Heater	1: running ; 0 Stop
22	4-way-valve	1: running; 0: stop
23	Bypass Valve	1: running; 0: stop
24	Hot Water Solenoid Valve G1	1: running; 0: stop
25	AC Solenoid Valve G2	1: running; 0: stop
26	Season Solenoid Valve G3	1: running; 0: stop
27	DHW Heater E1	1: running; 0: stop
28	AC Heater E2	1: running; 0: stop
29	C4 Water Pump	1: running; 0: stop
30	C5 Room AC Water Pump	1: running; 0: stop
31	C6 AC Assistant Water Pump	1: running; 0: stop
32	Working Current	Compressor DC Motor Current
33	OUT7 Status(g4, Free Cooling Valve)	1: running; 0: stop
34	Heat Target Temp	
35	DHW Target Temp	
36	Sterilization Target Temp	
37	Compressor Drive Module Temp	-30~97°C
38	Suction Temp	-30~97°C
39	Inner Pipe Temp(refrigerant Pipe Temp)	-30~97°C
40	Expansion Valve Opening Degree	Actual Open Degree (For Checking)

## C-Parameters Read-Only

41	Water Source Inlet Temp	-30~97°C
42	Water Source Outlet Temp	-30~97°C
43	Solar Water Tank Temp	-30~97°C
44	Return Lubricant Oil Function Status	1=Run;0=Stop
45	Indoor Temp	-30~97°C
46	AC Heating Target Temp	10-55C
47	Water Flow	0.1l/Min
48	Compressor Total Running Time1*1000 Hour	Over 1000 Digits
49	Compressor Total Running Time2	Below 1000 Digits
50	DHW TANK Coil Warning	When AC Inlet>50c, If AC Inlet-DHW Temp>10c,c50=1
51	EC C4 Water Pump Speed	0-10
52	Water Pump Duty Ratio	0-255
53	DC Fan 1 Rotate Speed	0-900
54	DC Fan 2 Rotate Speed	0-900
55	Running Mode (0=Off, 1=Cool, 2=Heat, 3=DHW)	
56	Target Frequency	30-90
57	Compressor Model Encode	CX34:C57=14, CX35:C57=16; CX50:C57=15
58	Low Pressure	N/a
59	High Pressure	N/A
60	Actual HP AC Return Water Temp	
62	Return Lubricant Oil Error Count On Display	See below^
72	Software Version No.	
73	AC Input Voltage	Line Voltage
74	Compensation Power	Output watts of V18
75	Stop Code	N/a
76	Busbar Voltage	DC Voltage to Compressor/ fan

## P-Parameters

LCD	Description	Meaning	Default
P00	Auto Restart After Power Off	0: Invalid; 1: Valid	1
P01	DHW Hot Water Temp Hysteresis Temp	2~15°C, Minus Hysteresis	2°C
P02	AC Temp Hysteresis Temp	2~15°C, Minus Hysteresis	2°C
P03	Coil Copper Pipe Temp To Active Defrost	-20~5°C	0°C
P05	Temp 2 To Active Defrost	-20~0°C	-5°C
P06	Coil Copper Pipe Temp To Stop Defrost	10~35°C	30°C
P07	Defrost Duration Time	15~99 Minutes	30
P08	Defrost Interval Time	15~99 Minutes	35
P09	Ambient Temp To Activate E1 DHW E-heater	-20~20°C	0°C
P10	Ambient Temp To Activate E2 AC E-heater	-20~20°C	0°C
P11	DHW Frequency Limitation Percentage	2~10 (= Highest Frequency* 20~100%)	10
P12	Compressor Discharge Air Protection Temp	100~127°C	100°C
P13	Defrost Interval Multiple Times Control	0: No Defrost 1~4; Defrost Interval Time Multiple Rate	1
P14	G3 Valve Function Selection	0: G3 Is Seasonal Switching Valve 1: G3 is Solar Valve	0
P15	Cooling Target Temp	10~25°C	12
P16	Heating Target Temp	(Au)10~55°C	45
P17	DHW Target Temp	(Au)10~55°C	50
P18	Sterilization Target Temp		65
P19	Fixed Speed At Manual Speed Control (For Factory Testing Only)	10~100 Hz	50hz
P20	Running Frequency Control Set (For Factory Testing Only)	0: Manual Frequency; 1: Auto Running Frequency	1
P21	EEV Manually Initial Open Degree (Heating)	40~480 When P23=0,1,2 It Is Fixed Degree, When P23=3, It Is Initial Open Degree	350
P22	EEV Manually Initial Open Degree (Cooling)	40~480 When P23=0,1,2 It Is Fixed Degree, When P23=3, It Is Initial Open Degree	350
P23	EEV Control Mode	0=No; 1=Checking Table; 2=Manual; 3=Auto	3
P24	EEV Over Heat Temp (Heating)	-5~10°C For Factory Only	0°C
P25	EEV Over Heat Temp (Cooling)	-5~10°C For Factory Only	0°C
P26	Water Pump Working Mode	0 = (Not Stop) 1 = Stop When Reach Temp、 2 = Run 1 Minute Every 15min.	0
P27	Second Heat Source Function	0: Invalid, 1: Normal 2nd Heat Source, 2: Together With E2, 3: Together With Gas Boiler	0
P28	Starting Air Temp For Second Heat Source	-30~15°C(On When Lower Than This)	-15°C
P29	Room Target Temp	10-28°C	21°C
P30	EEV Minimum Open Degree	40~200	80
P31	EEV Minimum Open Degree1	40~200	80
P33	Start Defrost Air - Coil Temp Difference	0~40°C	8°C
P36	Compressor Max Speed	10-200	80
P45	AC AU Curve Offset Value (Our Weather Compensation Curve AU)	-15~15°C	0°C
P46	AC AU Curve Max Temp Value (Our AU)	30~50°C	45

## P-Parameters

P47	Night Mode Validation Mode: DHW Increase 3C)	(Night	0 (Off) 、 1 (On)	0
P48	Night Mode Starting Time		0-23 (Time)	22
P49	Night Mode Ending Time		0-23 (Time)	6
P50	Flow Switch Minimum Enabled Water Flow Switch On (CN5)		6~60L/Min	6
P51	Local RS485 Address		0~99	1
P52	Water Flow Switch Type		0: No Water Flow Switch 1: YF-G1 Water Flow Meter "Black" 2:YF-DN50 Waterflow Meter "Not Used" 3:SEN-HZG1WA Copper Waterflow Meter	1
P53	Virus Killing Function Validation		0= Invalid; 1= Valid	0
P54	Cooling Function Validation		0= Invalid; 1= Valid	1
P55	Heating Function Validation		0= Invalid; 1= Valid	1
P56	DHW Function Validation		0= Invalid; 1= Valid	1
P57	Air Source Or Geo Source Selection		0= Invalid; 1= Valid	0
P58	Solar Source Validation		0= Invalid; 1= Valid	0
P59	Simple Or Inverter HP Selection		0= Simple; 1= Inverter Type	1
P60	Indoor PCB Enable Not Applicable		0= Invalid; 1= Valid	0
P61	Fan Selection		0= AC Fan; 1=DC Fan	1
P62	Heating Fan Highest Speed		71~100	90
P63	Fan Lowest Speed		30~70	50
P64	Manual Set Fan Speed		30~100	50
P65	DC Fan Speed Adjustment Temp For Heating		2-15°C	4
P66	DC Fan Speed Adjustment Temp For Cooling		3-18°C	5
P67	C4 Water Pump Selection		0: Normal 1:PWM	1
P68	C4 Water Pump Water Temp Difference		Range:1-10	5
P69	C4 Lowest Water Pump Speed		Range:2-8	4
P70	Restore Default Parameter		0: Normal 1: Restore Once	0
P73	G4 Heat Recovery Valve Selection		0:Parallelly 1: Serially 2 Free Cooling	0
P74	SSR Increase To Max Delay Time		1~20 Minutes	10
P80	Virus Killing Once		0: No 1: Kill Once	0
P81	Virus Killing Interval Days		X: 7 - 99 Days	7
P82	Virus Killing Start Time		Y: 0 - 23	1
P83	Virus Killing Duration Time		Z: 5 - 99 Minutes	10
P84	E2 Start Delay Time		5~15 Minutes	15
P85	Heat Recovery Module Enable (Not Used)		0= Invalid; 1=valid (Out16=heat Recovery Water Pump)	0
P89	Temp Unit		0=c; 1=f	0
P90	E2 Capacity W		0-25000	5500
P91	E2 Rated Voltage V		0~250	230
P92	E2 Heat Exchange Factor		0~600	500
P93	E2 Voltage Compensation V		-20~20v	0
P94	Cooling Temp Range (If Set To 1, Must Use Enough Glycol)		0:10~25; 1:0~25	0
P95	AC Antifreeze Start Temp		-15~7	5
P96	AC Heating Mini Frequency		30~50	30
P97	AC Cooling Fan Max Speed		71~100	90
P98	Free Cooling Start Air Temp		-16~20c	5
P99	Free Cooling Temp Difference		3~15c	5
P100	Error Reset		0: Not Reset; 1: Reset Once	0
P101	Resonance Range Bottom Point		30~p102	100
P102	Resonance Range Top Point		P101~44	100
P103	Heating Mode Start Air Temp		0~17	0
P104	Cooling Mode Start Air Temp		0~25	0
P105	EEV Max Degree When C19<40		50~240	240



## Error Codes

Error Code	Error Meaning
F01	Voltage Protection
F02	Compressor Drive Module PFC Error
F03	Abnormal Stop Of The Compressor When Running
F04	Compressor Drive Heat Sink Temperature Sensor Error
F05	Outdoor Current Sensor Error
F06	IPM Error
F07	Compressor Failed To Start
F08	Machine Overcurrent Protect
F10	Compressor Drive Module PFC Overcurrent
F11	Compressor Drive IPM Overcurrent
F12	Compressor Drive Module Comm Error
F13	Compressor Drive Module Busbar Voltage Error
F14	DC Fan 1 Error
F15	DC Fan 2 Error
E01	Exhaust High Temp Protect
E02	Outer Air Temp Sensor Error
E03	Pipe Temp Sensor Error
E04	AC Return Water Sensor Error
E05	AC Outlet Water Sensor Error
E06	DHW Tank Sensor Error
E07	Solar Water Temp Sensor Error
E08	Coil High Temp Protect
E09	AC Anti Freezing Twice
E10	Hot Water Anti-Freezing Twice
E11	Refrigerant (Indoor Coil) Temp Sender Error
E14	Suction Temp Sensor Error
E15	Exhaust Temp Sensor Error
	Or AC Antifreeze 3 Times Within 20 Minutes
E18	Error For Inlet And Outlet Water Temp Difference Too Small
P01	High Pressure Protect
P02	Low Pressor Protect
P03	Overheat Protect
P05	Water Flow Error
P06	Water Source Water Flow Error( Ground Source Model)
P07	Phase Loss
P09	Water Source Antifreeze( Ground Source Model)

## Dynamic Outdoor Reset Control

The Chiltrix CX34-4 unit is equipped with an automatic outdoor reset function that can be accessed via the onboard controller.

### Advantages & Misconceptions of Using Outdoor Reset

Most people in the radiant heating industry will tell you that outdoor reset is used to get more BTU delivery from the radiant system on a day when the radiant system can't deliver enough BTUs to keep up with the load, and they use outdoor reset to crank up the radiant heat operating temperature to 120F, or higher. While that's true, it's also true that the best designed air to water radiant systems will be able to deliver what's needed at a fairly low temperature even with severe outdoor design conditions.

So if you can't get enough radiant capacity into the floor, then if possible, add some to the walls or ceiling. Note that radiant heat works just as well from the ceiling or walls as it does from a floor. And in some cases, it works better from the ceiling.

#### Why does keeping the operating temperature low matter so much?

With a fossil fuel burning boiler, it doesn't matter. Gas, propane, and oil efficiency does not vary with outdoor temperature. But that's not the case with a heat pump.

Here's why:

$$W = \frac{Q_1}{COP_p} = \frac{Q_1(T_1 - T_2)}{\eta_{mech} T_1}$$

For a real-world example, at 0F outdoor temperature, an air to water heat pump such as the CX34 will have >20% higher capacity when used with an operating temperature of 95F compared to operating at 122F. And COP at 95F will be >30% higher at 95F than at 122F.

#### So why use outdoor reset?

You can use reset when it is simply not possible to design the indoor side of a system to handle the peak BTU load using a low operating temperature. **But the best use of reset is as a strategy for extra energy savings**, by designing the indoor side of the system to handle the peak load at the lowest possible operating temperature, **and then letting the system automatically reset to an even lower and even more efficient temperature at times when weather is milder!**

## How to Use Chiltrix Dynamic Outdoor Reset Control

### Use With or Without V18-B Backup Heat

Use the free Excel curve development worksheet tool to create the proper curve and discover correct parameter settings for P45 and P46. The tool is located at <https://www.chiltrix.com/dynamic-heat-reset>

**Make sure you select the correct tool for your model.**

Set parameter P45 and P46 in CX34 controller according to the values used in your curve worksheet.

There is an "AU TEMP" icon inside of the mode section of the main screen of the controller. If you press on it then you will enter the AU TEMP mode screen. You will need to enable "HEATING AU" to ON. With AU Heating on, it will be displayed as an orange/red color.

From there you can adjust the "weather compensation curve AU offset" and the "AC Heating AU curve max temp value". The "AU" will also be illuminated on the main screen around the heat mode.

Enable AU of heat mode as shown below.

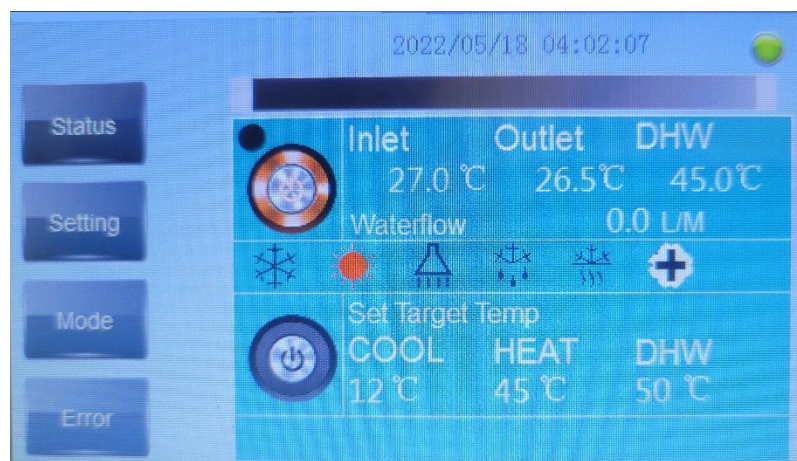
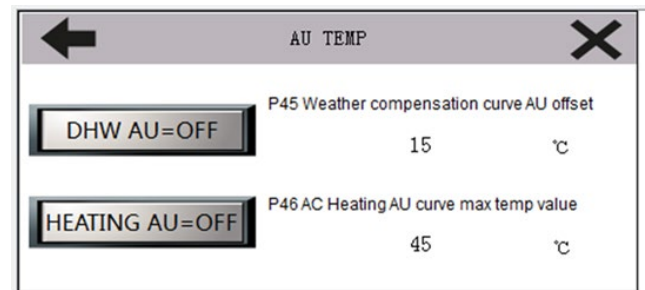
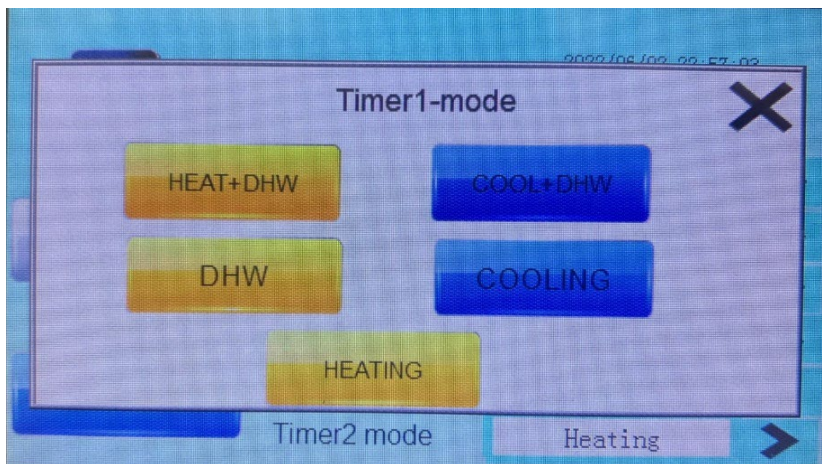

## How to Use Automatic Switch-Over

This is now an on-board function and does not require a separate add-on controller to operate. This function allows the CX34 to automatically select its mode, either heating, cooling, or standby (off), according to outdoor temperature. This can be particularly useful for example, if a single CX34 is shared by two different tenants, allowing the property manager to (automatically) select the mode according to the actual outdoor weather conditions.

There is a minimum of 5C (9F) deadband built-in so as to limit daily switching. A suggested setting would be to run in heating mode when outdoor temperature is 60F or below, use cooling when outdoor temperature is 69F or above, and between 60-69 the system will be in standby (off) mode.

If your CX34 is used with a Psychrologix controller, please make sure the Psychrologix auto-switchover function is disabled and only use the on-board automatic switchover function. Or, vice-versa. Only one method of external control can be used on the same system. Likewise, this function cannot be used on either controller if you are using C-H-COM remote relay mode control.

To use this function, follow these 6 steps:

1. Make sure that C-H-Com are NOT being used. The jumpers that are supplied should remain in place as shown on page 28
2. Note that P103 and P104 temperatures are in C not F.
3. The settings P103 and P014 must be at least 4C different between each other.
4. Result: If outdoor air drops below P103 the system will switch to heating.
5. If outdoor temperature rises above P104 the system will switch to cooling.
6. The default setting of P103 and P104 is 0. This means the autoswitch function is disabled. If you change either of these to a number other than 0 the function will be enabled.

## Commissioning “To Be Performed In Heating Mode Only” An as-built design will need to be provided to Chiltrix by email before the commissioning call.

**For Commissioning please arrange a commissioning call with Chiltrix Support Dept. +1 757-410-8640 Ext. 112**

### **PLEASE MAKE SURE TO CALL CHILTRIX BEFORE COMMISSIONING**

#### Preparation

After finishing the installation tasks, please check the items below:

1. Check the Wired Controller P Parameters for the most updated settings.
2. Check that the power cable is securely connected and the screws are tight.
3. Is the display lit on the wired controller after the power is applied?
4. Verify that all the shut off valves and manual valves are open. Insulate all water supply and return pipes.
5. Test only in **heating mode** to verify proper water flow.

Water or Glycol Filling (See page 28) A 10% minimum glycol mixture is required to protect the unit from freezing and provide corrosion inhibition. Refer to the chart on page 10.

1. With a hose and filling pump connected to the CX34 water system, and all air exhaust valves open in the water system, fill the water loop with water and glycol mixture. Keep the air exhaust valves open until there is a continuous flow of water and glycol mixture coming out of the air exhaust valve. Then close the air exhaust valves. See page 30 and 31 for more details.
2. Discharge the air from both domestic hot water system and air conditioning water system. CXI fan coils have a bleeder valve located near the inlet and outlet ports. The CX34 has a bleeder tube attached to the Brazed plate heat exchanger.

***To avoid freezing the heat pump when the air temperature drops below 32F in winter, you must use an appropriate glycol and water mixture just in case the electricity is cut off. We recommend biodegradable non-toxic HSE Corn Glycol, any Propylene Glycol (PG) can be used.***

Running a Test- Call tech support if this is your first time commissioning a CX34.

Apply power to the CX34 and select **heating mode** using the wired controller. If there is not enough flow in the system or air in the lines and you will get P5 and possibly P1 errors. Call tech support if any error codes are displayed on the wired controller.

**Chiltrix Tech Support hours of operation, M-F, 9 am-6 pm EST, 757-410-8640 x112**

#### **MOST IMPORTANT!**

1. Always maintain an electrical connection with heat pump to enable the antifreeze function. 2. Initial test should be done in **heating mode**. Make sure it is not in cooling mode during first operation or running a test, until you make sure the circulation pump is working properly and water is flowing properly. Failure to do so will likely damage the heat exchanger and not be covered under warranty.

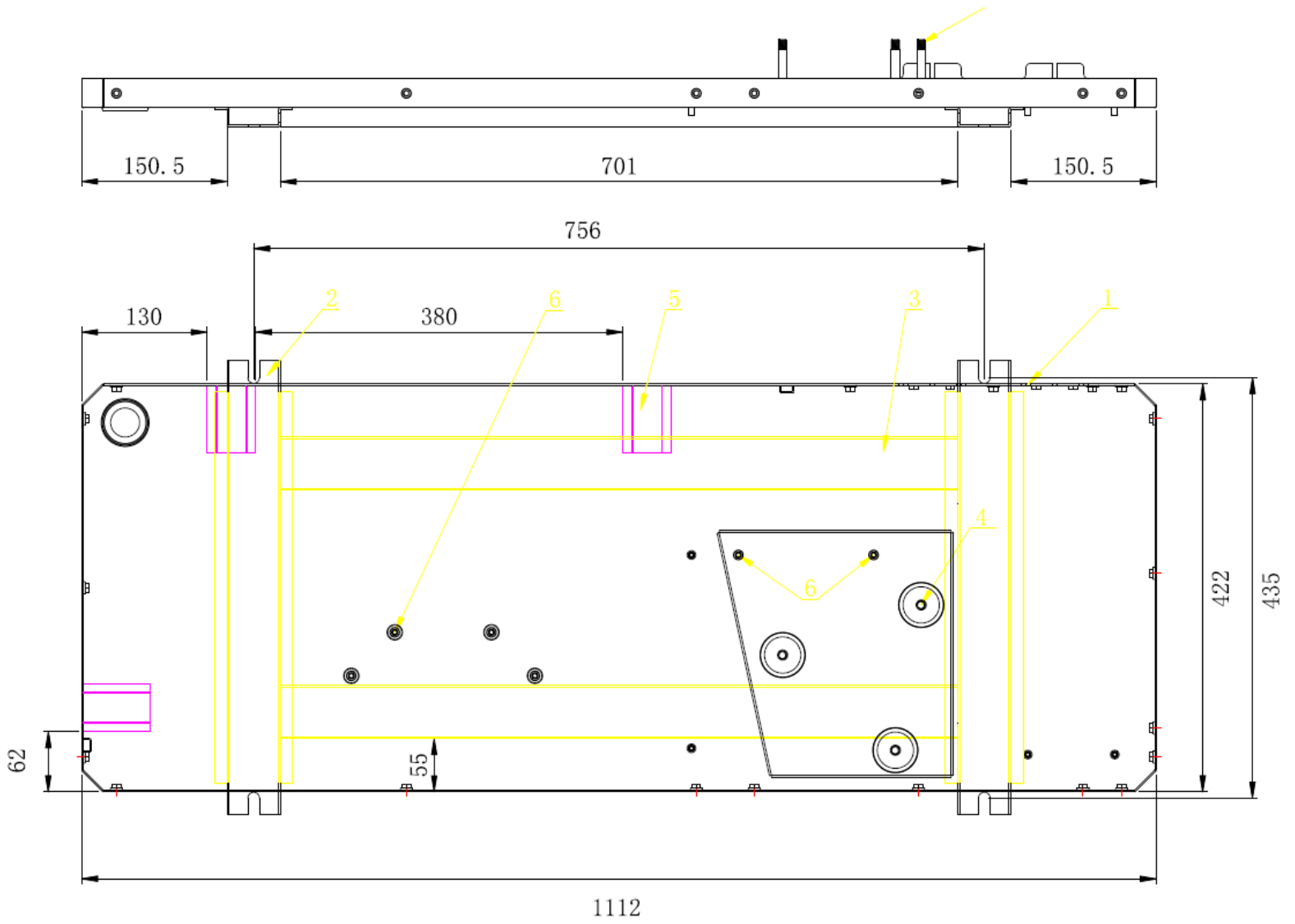





Chiltrix CX34 Internal Pump:  
Wilo Yonos PARA RS 25/7.5 PWM1 Ku

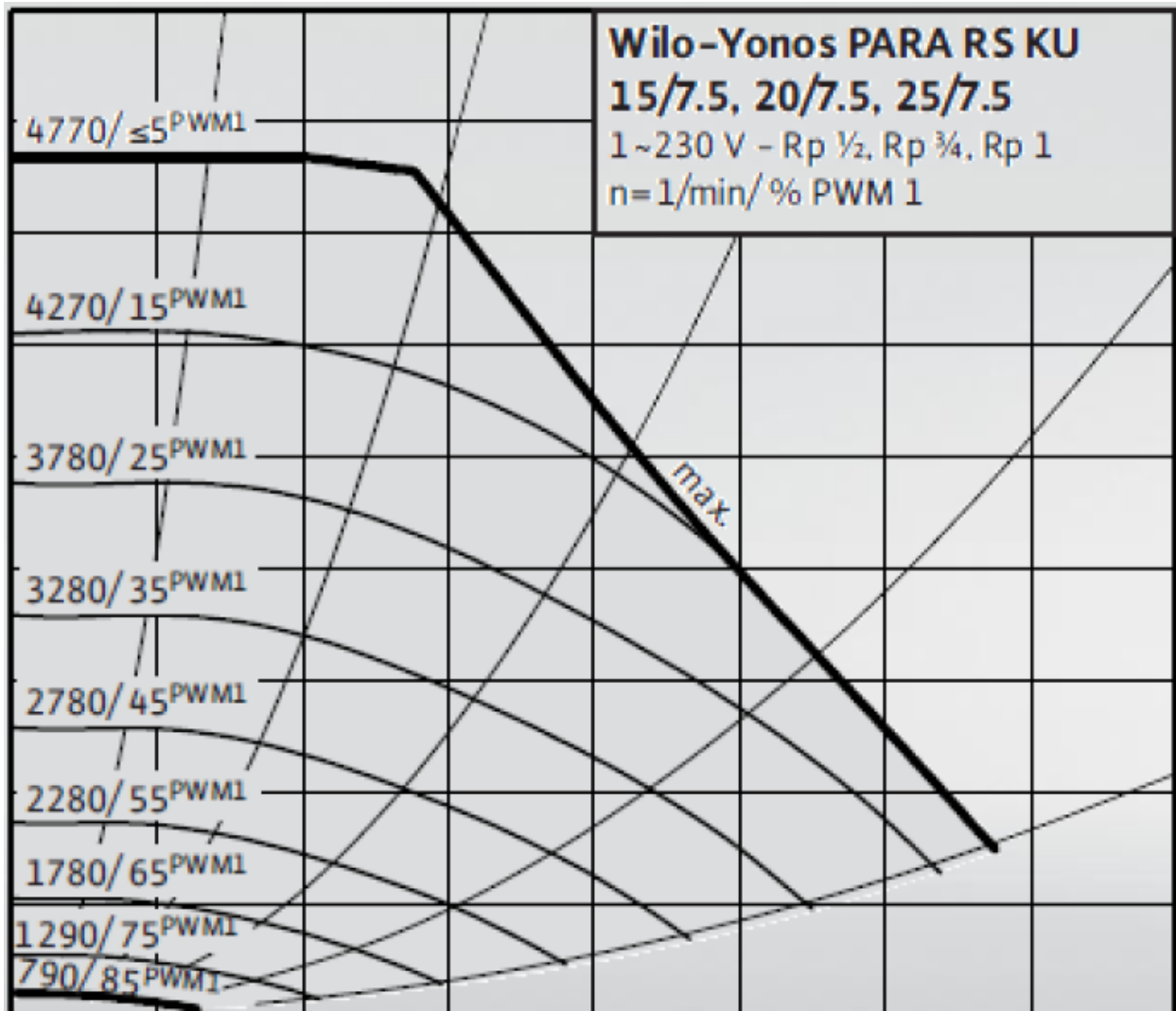

## Extending Wires

If you need to extend any of the sensor wires, control wires, MODBUS wires, please follow the instructions below as the wires are very sensitive to resistance and EMF.

Cut and strip the wire ends (1) that you wish to extend.

Twist the wires together (2) and then solder the wires (3) to create a good connection. Then cover the exposed solder and wire with heat shrink (4) and make sure you have a solid connection.

DO NOT use crimp style butt connectors, the small gauge wire tends to get cut when you crimp down on the connector.

**For extending Psychrologix cable, make sure to follow the twisted pair twist pattern.**

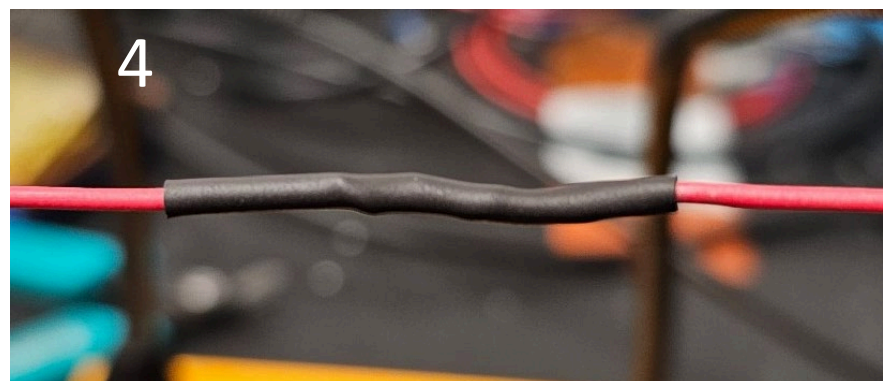
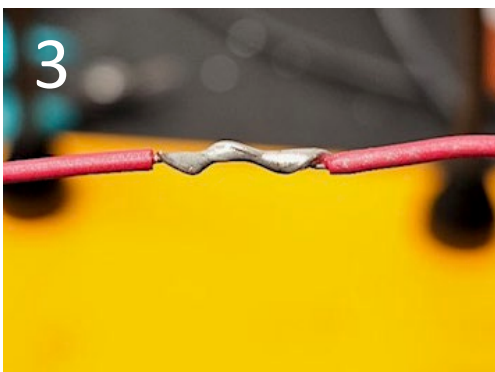
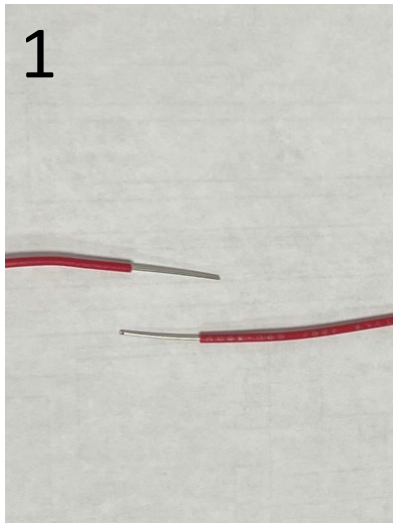

**DO NOT Run the modbus, temp sensor, dhw sensor, controller wires, or any logger wires in the same conduit as high voltage wires (120VAC or more). This will impede the accuracy and will cause communication problems. AVOID PASSING CONTROL WIRES NEAR ANY MOTORS OR INDUCTIVE LOADS OR DEVICES THAT EMIT EMF**

Some Grundfos pumps will ship with a power cable already attached. Some models you will need to run your own power wire. Wire from the chiller terminal block to the pump should be at least 20 Gauge or larger. The pump draws very low amps. You should also install ferrule crimps on the pump side wires and fork or eyelet connectors on the terminal block side.

Below is a schematic of how to run the power wires from the outdoor logic board to the pump. You will also need to run the control wires as stated earlier. Gnd is common to the ground coming into the unit and chassis ground.

