



## Compatible w/ 99% of All Radiant Heating Controllers

A Product of Chiltrix, Makers of the World's Most Efficient Chiller Heat Pumps

### What it Does:

The CXRC1 monitors up to eight dew point sensors and makes sure that a chilled water heat transfer fluid (water or water/glycol mix) entering the radiant supply manifold is at a temperature according to a user-defined delta to the dew point, to prevent unwanted condensation, while allowing the coldest possible noncondensing fluid temperature. The CXRC1 radiant cooling controller's dynamic operation allows a standard radiant heating system, when used with a heat pump or other chilled water system, to successfully operate as a radiant cooling system without producing unwanted condensation.

### Application:

Radiant cooling can be used in dry or moderate climates to add cooling functionality to a standard radiant heating system, with the addition of a chilled water source and a CXRC1 radiant cooling dew point controller. Radiant cooling can also be used in humid climates for augmentation or other special purposes. Contact Chiltrix for free expert application engineering. The CXRC1 is a stand-alone device and can work with all standard radiant heating controllers. The CXRC1 is not a full radiant controller, it is an add-on to a standard radiant controller. The radiant controller will need to use thermostats that include a cooling function.

### How it Works:

The CXRC1 radiant cooling dew point controller monitors the indoor dew point and dynamically adjusts the fluid temperature to the coldest safe noncondensing temperature for maximum cooling capacity while preventing condensation (prevents wet floors). Allows user adjustable dew point hysteresis.

**V1.2 Bonus Feature: Radiant Hardwood Floor Over-Temp Protection** See manual for details

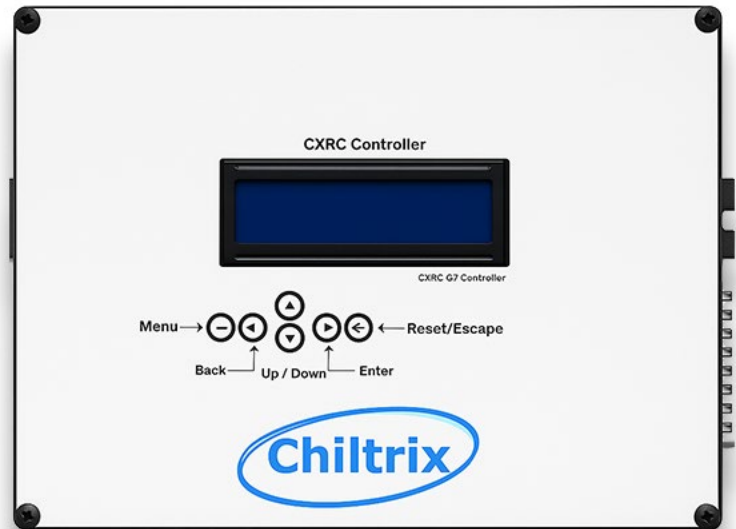

### Benefits of Radiant Cooling:

Radiant cooling offers the absolute highest possible heat pump or chiller cooling efficiency, up to seasonal average EER 64 and beyond.

Cooling without forced air provides superior comfort and indoor air quality (dust free air). Allows existing radiant heating PEX or panel infrastructure to be used for cooling without adding ducts or fan coil units. A high-efficiency dehumidifier can be enabled during times of high humidity.

### CXRC1 Includes:

**Control unit w/ LCD user Interface.**

**Up to eight (8) dew point Sensors.**

**Temperature sensor w/ sensor well.**

**Fast-acting Siemens Mixing Valve.**





# CXRC1 V1.2 Radiant Cooling Dew Point Controller

A Product of Chiltrix, Makers of the World's Most Efficient Chiller Heat Pumps

As with radiant heat, anyone who ever has had radiant cooling would never willingly give it up. Never. It simply feels better. When you eliminate forced air, the indoor air quality itself is vastly improved as dust, mites, pollen, etc. that would normally remain in the air, fall to the floor and are removed by the vacuum cleaner.

Also, with radiant cooling the heat pump system efficiency is dramatically improved. For example, you can see from the AHRI-certified performance data of the Chiltrix CX34, in normal operation it has a record-setting seasonal average EER. But when used for radiant cooling, the same official data shows the seasonal average EER increase by 31%, and under certain conditions can rise over 40% above its worlds-record baseline. Further, radiant cooling allows a higher indoor set point without sacrifice of comfort, reducing  $\Delta T$  and building heat gain (lowers the load).

### Best of Breed Components:

As with the U.S Department of Energy Award-Winning Chiltrix CX34 heat pump chiller, the Chiltrix CXRC1 uses only the finest components available.

### CXRC1 components include:

- ATmega2560 RISC Microcontroller
- Siemens AG Valve Controller & Brass Mixing Valve
- Heraeus Platinum RTD Sensor
- Amphenol Dew Point Sensors
- Triad Magnetics Power Supply
- Solid Brass PT100 Sensor Well

No other valve & actuator can match the accuracy of the Siemens solution, likewise the Amphenol sensors we use have >2x the accuracy of a standard dew point sensor. This allows a safer and more advantageous hysteresis setting.

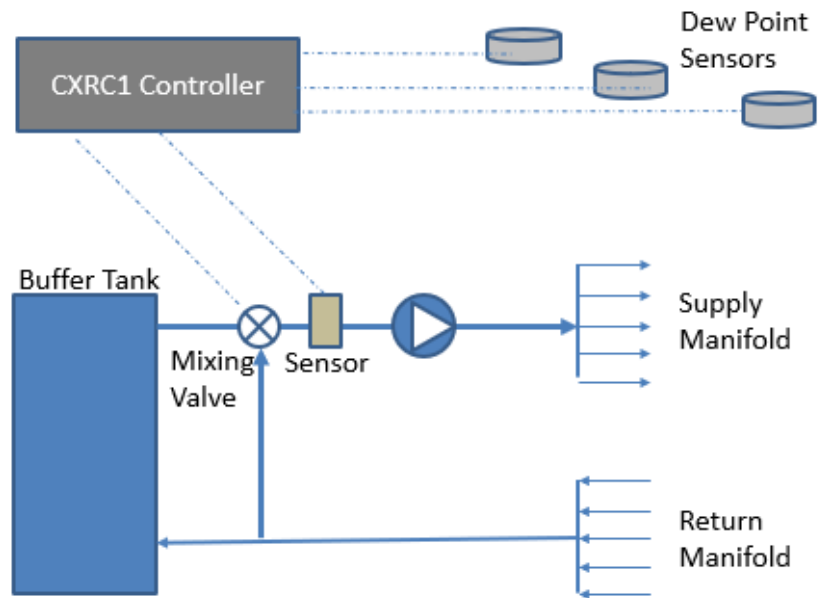

- 1x PT100 sensor Inputs
- 4x or 8x Dew Point Sensor Inputs (RJ45)
- 1-4, or 4-8 Dew Point Sensors
- Optional RS485 (Modbus slave or master)
- Output for Actuator
- Optional Relay output
- Optional Alarm Output

The CXRC1 connects to the dew point sensors via standard CAT5 or CAT5e cabling which can be located up to 150 ft. away from the controller.

Sensors: W 3.2" H 1.5" D 2.5" including tabs.  
Controller: W 5.5" H 1.5" D 3.8"

Use with Chiltrix award-winning and record-setting air to water heat pump, or use with any other chilled water source.



Distributed By:



HotSpot Energy Inc.  
4021 Holland Blvd.  
Chesapeake VA 23323  
www.hotspotenergy.com

[info@hotspotenergy.com](mailto:info@hotspotenergy.com)

1-757-410-8640

