

DC INVERTER

**AIR TO WATER HEAT PUMP**

**For Use with CX50 units with serial number range of CX5022035001 or higher.**

(If unsure, contact Chiltrix technical support dept. with the serial number)

## **Installation and Operation Manual CX50-2 Options for Heating, Cooling and Domestic Hot Water**



**PLEASE REVIEW ENTIRE MANUAL BEFORE PROCEEDING**

**PLEASE SUBMIT SYSTEM DRAWING & SCHEDULE A COMMISSIONING  
CALL BEFORE STARTING THE UNIT**

Cx50-2 Version 1.4

## Table of Contents

Safety Precautions.....	Page 3
CX50 Components.....	Page 4
Hydronic Piping and Design.....	Page 6
Buffer Tanks.....	Page 9
Head/Pressure Drop Calculations.....	Page 10
Using Glycol.....	Page 13
Heat Pump Installation.....	Page 14
Stainless Steel Pump.....	Page 18
Valves G2, G3.....	Page 23
Second Heat Source.....	Page 29
External T-Stat Control.....	Page 30
System Filling/Purging.....	Page 32
Using The Controller/Operation.....	Page 34
Settings Menu .....	Page 35
Status menu.....	Page 36
Administrator Functions and-Parameters.....	Page 43
Mode Switching .....	Page 45
P-Parameters, C-Parameters and Error code Lists .....	Page 48
Dynamic Outdoor Reset Control .....	Page 55
Auto Switch-Over .....	Page 57
Commissioning .....	Page 58
Extending Wires.....	Page 59

**IMPORTANT NOTE – MAKE SURE TO PROVIDE YOUR DESIGN DRAWING FOR APPROVAL BEFORE GETTING STARTED, INCLUDING DESIRED OPERATING TEMPERATURES.**

### Safety Precautions

**NOTE: It is required to read the Safety precautions in detail before operation. The precautions listed below are very important for safety, please follow all safety precautions.**

#### General

- Make sure that the ground wire in the building is securely connected to earth.
- Wiring tasks should be carried out by qualified electricians only, in addition, they should check the safety conditions of power utilization, for example, verify that the line capacity is adequate, and the power cable isn't damaged.
- Users must not install, repair or relocate the unit. Improper procedures might lead to accidents e.g. personal injury caused by fire, electrical shock or unit's falling off its base, and water leaking into the machine. Please contact a professional service department if problems arise.
- The unit shall not be installed at a spot with the potential hazard of leaking flammable gas. If gas is leaking near the machine, there might be the risk of explosion.
- Make sure that the foundation of the unit is stable. If the foundation is unstable, the outdoor unit may come loose from its base and cause injury.
- Make sure that the GFCI installed at the service panel is working properly to avoid shock or fires.
- If any abnormality occurs in the unit (such as a burning smell is noticed inside the unit), cut off the power supply immediately, and contact a professional service department.
- Please observe the follow items when cleaning the unit. Before cleaning, shut off the electric supply of the unit first to avoid injuries caused by the fan operation.
- Do not rinse the unit with water because the rinsed unit may cause electric shock.
- Make sure to shut off the electric supply before maintaining the unit.
- Please do not insert fingers or sticks into air outlet or air inlet.

#### Transporting and storage

The machine must be transported and stored vertically at all times

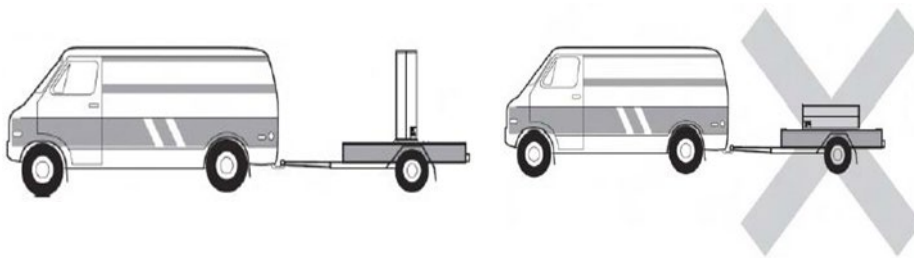

Systems Without Glyco

**IMPORTANT:** Please refer to ALL of the appropriate documents for your system including V18 Manual, Tank Manual, etc. PLEASE SEE THE DOCUMENTS PAGE HERE <https://www.chiltrix.com/documents/>

# CX50 Components

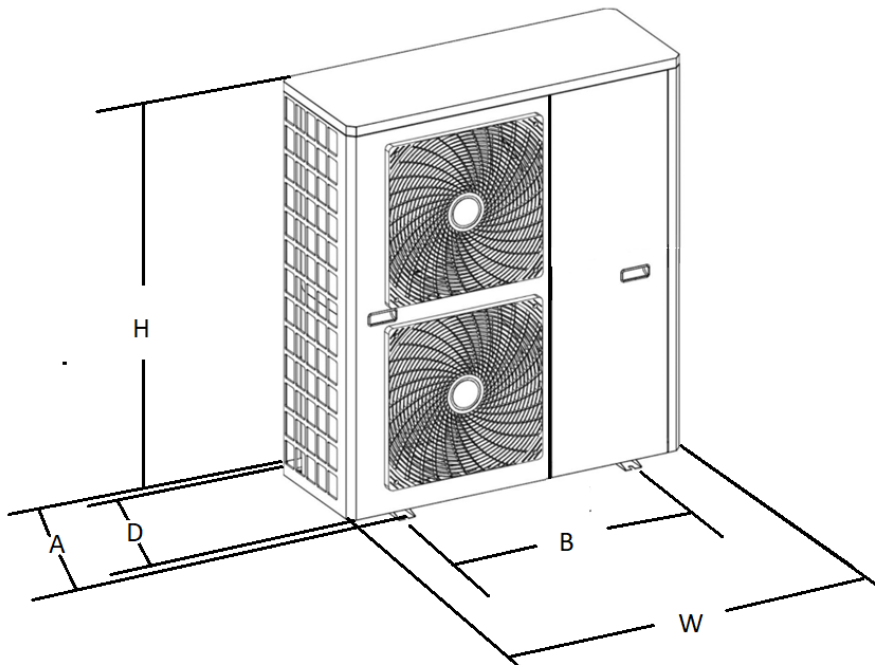
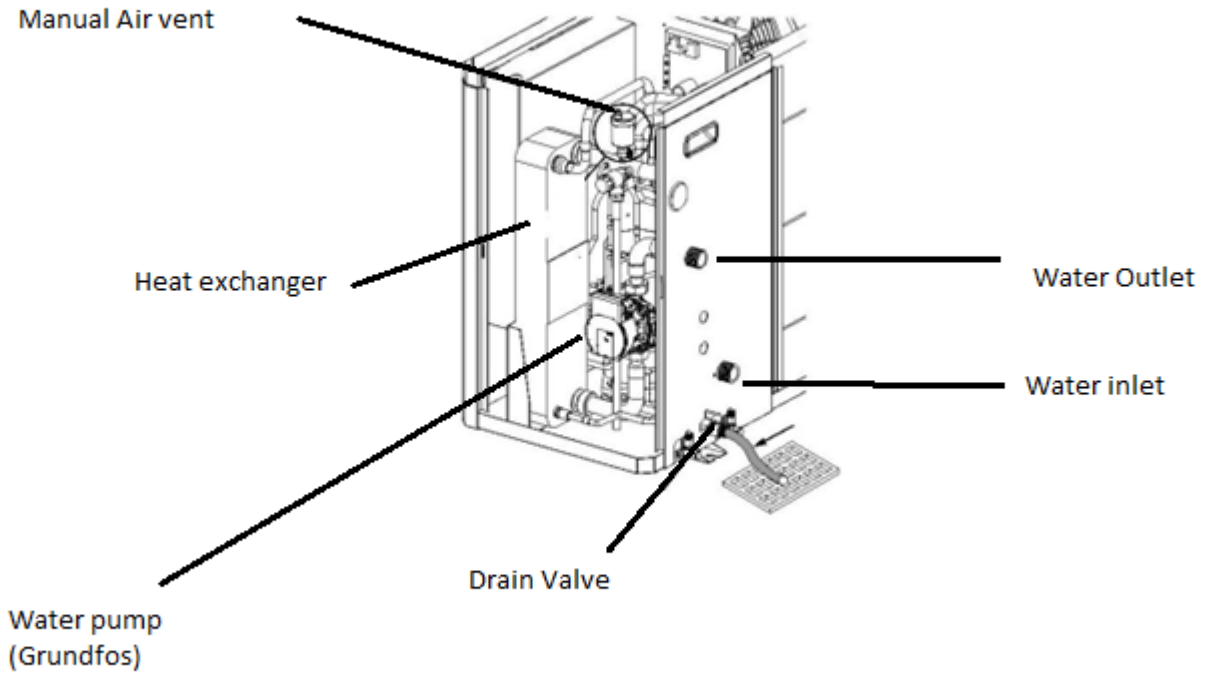

Dim	Inches
A	17.5
B	29.5
D	17
H	50
W	44.5
D Inc Fan Shroud	18

## CX50 Components

### Ball Valve

Located in the chiller (taped to on of the compressor legs) is a small ball valve used to drain the unit to service the pump or any other internal parts.

**NOTE: You must install this valve or else the unit will leak when filled with water/glycol! Make sure you use Teflon tape on the threads.**

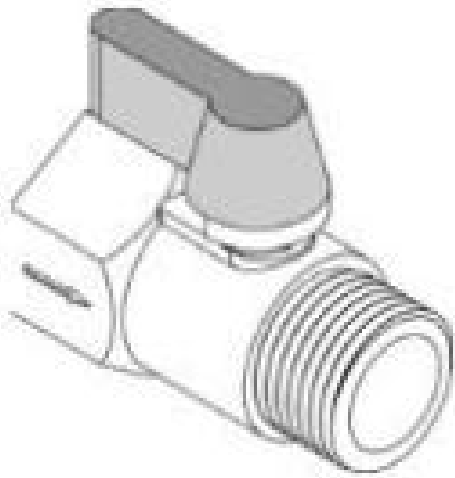

## Hydronic Piping and Design Guide

### Installation Methods Heating and Cooling (Heating Shown)

See Design Guide Here  
<https://www.chiltrix.com/documents/chiller-options.pdf>

**PLEASE ALWAYS SUBMIT YOUR DESIGN TO  
 CHILTRIX FOR APPROVAL**

Note: Primary Secondary Piping or Closely Spaced Tees are NOT supported or recommended for use with this heat pump on the supply-side of the buffer tank, or anywhere in a system without a buffer tank.

A buffer tank must be used for radiant heating. A multi-port buffer tank such as VCT37 should be used to combine multiple heat pumps. Please do not try to balance multiple cx50 units with equal-piping or reverse return design. It will not work as expected due to having multiple variable speed pumps.

An “additional volume” tank must be used when there is no buffer tanks and there is less than 15 gallons of total system fluid volume.

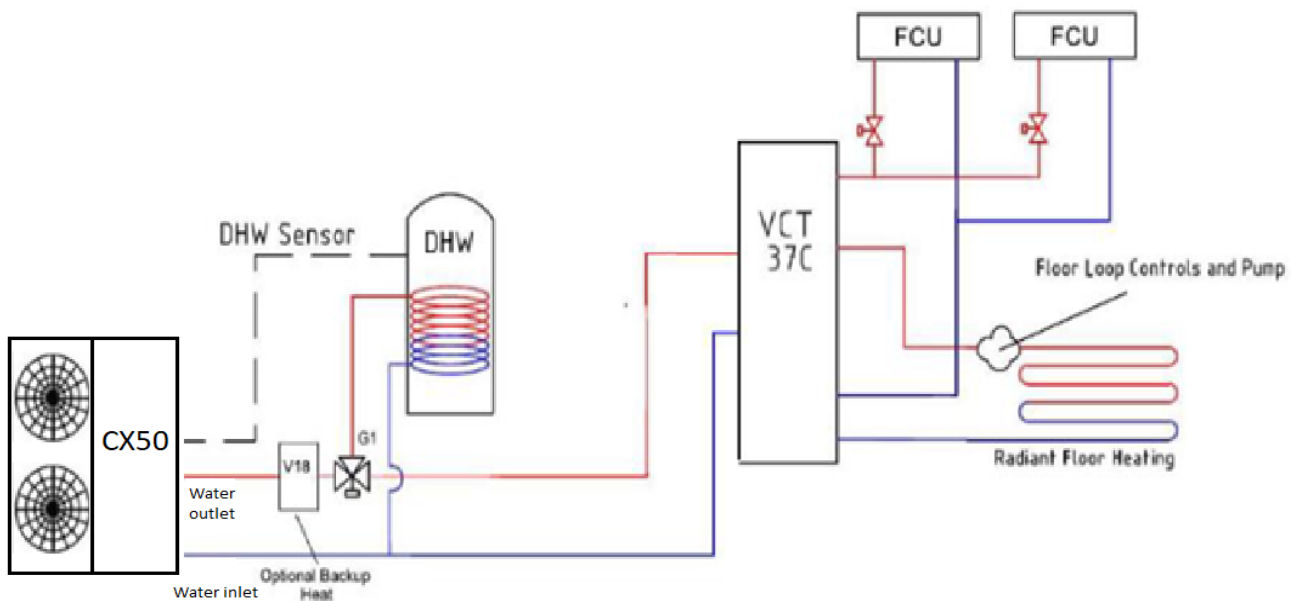

Minimum pipe size should be no less than 1”, CPVC or Oxygen Barrier PEX, reverse return piping is preferable to assist balancing. Reverse-return will not fully balance multiple chillers as the variable speed pumps may not always operate at the same speed. The installer should calculate the pipe and fitting resistance to determine the head pressure. See the examples on the following pages, maximum water flow for the cx50 is 10-12.5 gpm, design flow is 5.2 gpm. If necessary, a second Chiltrix-provided PWM pump may be added to the loop and controlled by the cx50. The second water pump connections are always in series with the internal pump. The loop example above is designed with wild coils (loads). The above shows a single heat pump, with inline dynamic/variable backup, domestic hot water, a buffer tank, serving radiant and fan coil/AHU units.

Chiltrix is always available to provide a free custom design, we encourage you to let us do this for you.

An air discharge valve should be installed at the top of the circulation system, if possible, for easy air discharge. As an alternative an automatic/manual air vent can be used inline before the pumps.

**Always install a water filter or wye strainer on the return side pipe before it enters the heat pump to prevent blockage of the heat exchanger or pump/flow meter problems. A blocked heat exchanger can be a costly problem and is not covered by warranty so make sure to use a filter.**

Do not use CPVC if glycol percentage will be above 25%. Do not use PVC.

## Piping Examples: Stacked Heat Pumps

Preferred Method For 2 or 3 Units:

See Design Guide Here  
<https://www.chiltrix.com/documents/chiller-options.pdf>  
**PLEASE ALWAYS SUBMIT YOUR DESIGN TO CHILTRIX FOR APPROVAL**

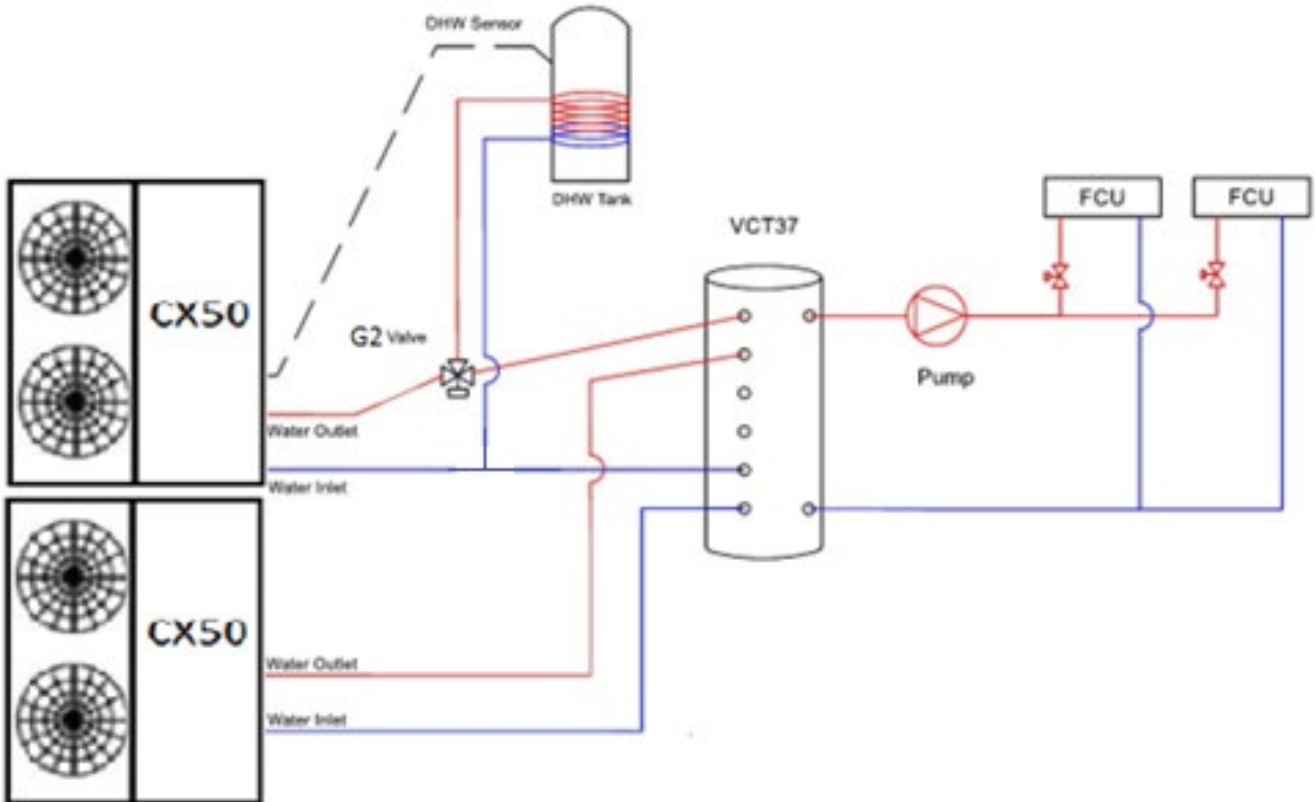

**NOTE about fittings: All Chiltrix V18, tanks, etc., have stainless steel fittings. It is difficult to connect stainless to stainless, we suggest use brass fittings for all connections**

**PLEASE SEND YOUR PROPOSED FINAL DESIGN TO CHILTRIX SUPPORT DEPARTMENT FOR APPROVAL, COMMENTS, AND SUGGESTIONS**



## Piping Examples

See Design Guide Here  
<https://www.chiltrix.com/documents/chiller-options.pdf>

**PLEASE ALWAYS SUBMIT YOUR DESIGN TO CHILTRIX FOR APPROVAL**

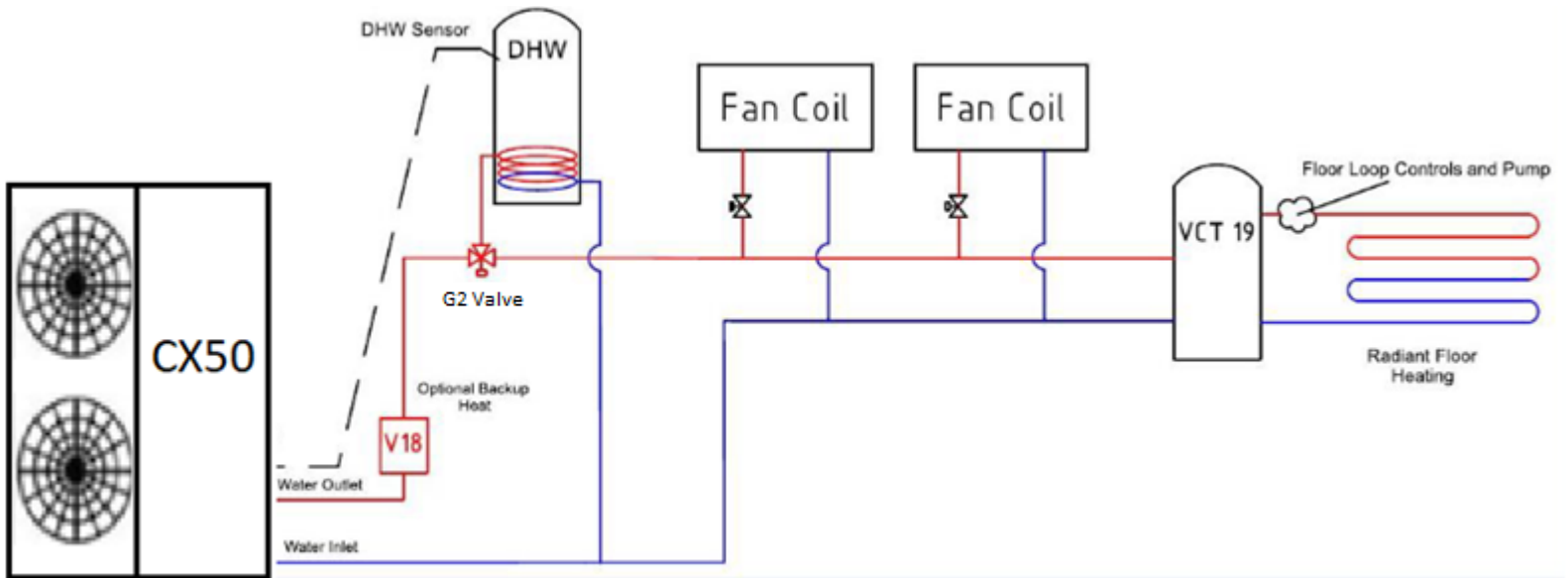

Note: The above design should not be used for more than 2x fan coil/AHU units totaling  $\leq 12$  kbtu capacity. Otherwise, consider using a VCT37 tank and locating the fan coil/AHU units on the load side of a buffer tank.

**PLEASE SEND YOUR PROPOSED FINAL DESIGN TO CHILTRIX SUPPORT DEPARTMENT FOR APPROVAL, COMMENTS, AND SUGGESTIONS**

### Pipe Insulation

All loop piping must be insulated per local and national mechanical codes. Any piping in a system with chilled water (used for cooling) must also be sealed vapor tight to prevent condensate issues. For design tips and a thickness calculator please visit

<https://www.armacell.us/solutions-center/>



## Using a Buffer Tank w/ Radiant

Example below shows optional DHW, optional V18 backup heater, and radiant. The radiant is attached to the load side of a buffer tank.

If a radiant system is to be used for cooling, please review this page <https://www.chiltrix.com/radiant-cooling/> and contact Chiltrix for assistance in evaluating your application and for design assistance.

For V18b information please see the V18b Manual available on the Chiltrix website documents page.

For DHW or buffer tank installation information see the Chiltrix Tank Manual.

See Design Guide Here  
<https://www.chiltrix.com/documents/chiller-options.pdf>

**PLEASE ALWAYS SUBMIT YOUR DESIGN TO  
 CHILTRIX FOR APPROVAL**

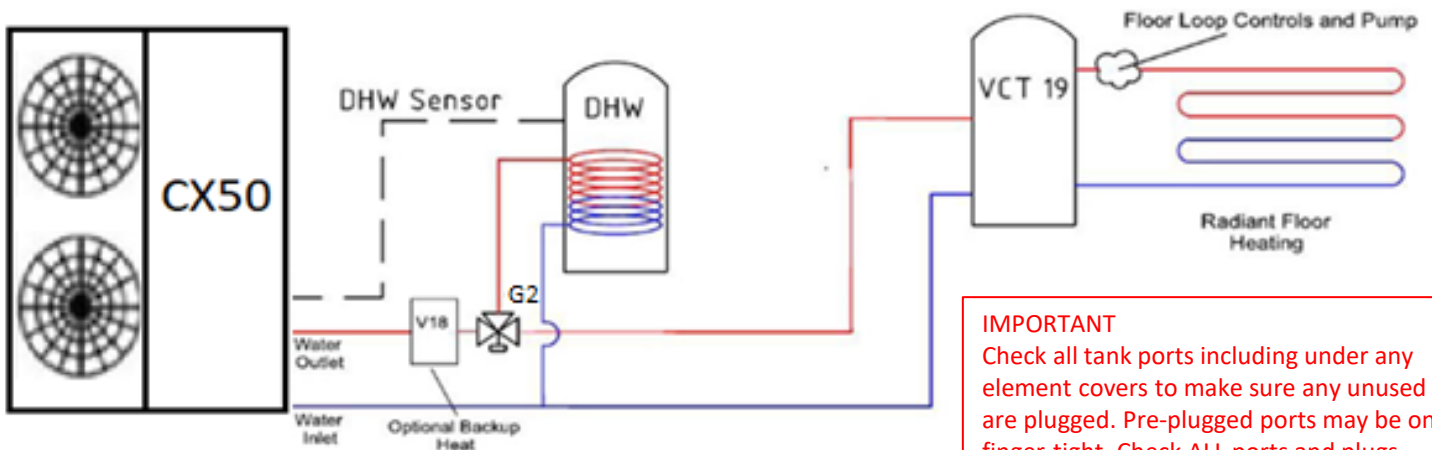

**IMPORTANT**  
 Check all tank ports including under any element covers to make sure any unused ports are plugged. Pre-plugged ports may be only finger-tight. Check ALL ports and plugs for water tight fit.

Primary / secondary piping is not supported, when connecting to a floor heating loop always use a buffer tank. Buffer tanks are not always needed (except for radiant they are always needed) with the Chiltrix system, buffer tank is needed to combine multiple heat pump outdoor units, but are still always recommended to improve performance.

### IMPORTANT NOTE ABOUT BACKUP HEAT

Do not ever use heating elements in a buffer tanks for backup heat. The element capabilities of the buffer tank are provided for emergency heat only. Not “backup” heat. Contact Chiltrix with any questions about emergency or backup heat options. See details in the Chiltrix Tank Manual.

The radiant loop pump in the buffer tank drawing is controlled by the customer’s radiant controller. The buffer tank isolates the Chiltrix internal pump from other pumps, and in the case of multiple heat pumps, from each other - providing hydraulic separation and thermal buffering.

A 19 (or 37) gallon buffer tank is used generally for best performance with a single cx50. 37 or 58 gallons is used for systems of two or three cx50s, note that a VCT37 or VCT60 is always used when multiple cx50s are to be combined, with a vct60 always used for 3x cx50.

See more designs here:

<https://www.chiltrix.com/documents/chiller-options.pdf>

### Head Calculation Example:

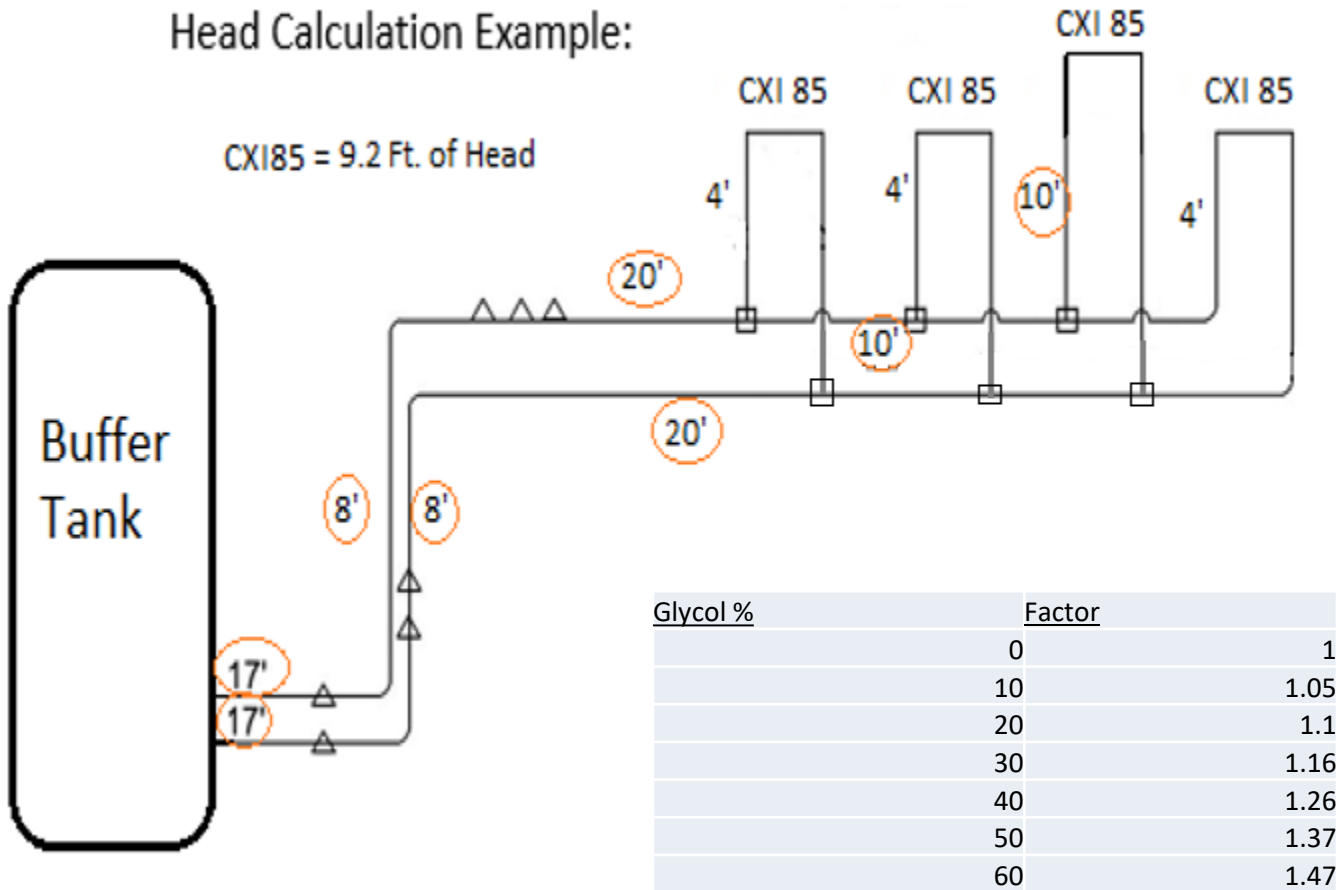

Glycol %	Factor
0	1
10	1.05
20	1.1
30	1.16
40	1.26
50	1.37
60	1.47

To calculate the head pressure for the correct water flow, the pipe length must be measured and all fittings counted. It is advisable to use flexible red oxygen barrier PEX piping and route it so as to avoid as many elbows as possible.

All fittings have an equivalent length of pipe already calculated, available on the next page under PEX Fittings Pressure Drops.

All measurements in feet

6 Tees @ 2.3ft. Of pipe = **13.8** ft. of pipe

7 Couplings @ 1.3 ft. of pipe = **11.7** ft. of Pipe

**120'** of actual 1" Pex Pipe

**145.5'** of equivalent Pex.

145.5'/100= 1.455'

1.455' x 6.67(Ft of head per 100ft of 1" Pex @ 7gpm)x1.05(glycol factor) = **10.19Ft** of head loss based on frictional losses

CXI 85 Fan Coils = 9.2 ft. of Head

Total Head = 9.2ft + 10.19ft = **19.39 ft.**

## Head Calculations - Continued:

The previously shown example loop has a volume of 4.5 gallons. The internal thermal expansion tank is 2 liters or .52 Gallons. The volume of the cx50 is 5.5 liters. An additional thermal expansion tank is likely required for larger loops. There are many thermal expansion calculators on the internet, the following is an example.

<http://westank.com/calculator/>

Minimum loop pressure is 14.5 psi, maximum pressure is 43.5 psi, and ideal pressure is 29 psi. The lowest temperature is 44°F, the highest temperature is 131°F, the Initial pressure is 14.5 psi, and the final pressure is 29 psi.

A microbubble air separator should be installed in the loop preferably in the higher part of the loop to remove any air in the circulation loop. Always install a water filter or wye strainer on the supply pipe to the chiller to prevent blockage of the heat exchanger or damage to flow meter.

Nominal size	OD	Wall thickness	ID	Volume gal/100'
3/8"	0.500	0.070	0.350	0.50
1/2"	0.625	0.070	0.475	0.92
5/8"	0.750	0.083	0.574	1.34
3/4"	0.875	0.097	0.677	1.83
1"	1.125	0.125	0.863	3.03



WYE STRAINER (from supplyHouse.com)

**THE WYE STRAINER SHOULD BE CLEANED OUT AFTER 1-2 DAYS OF OPERATION TO REMOVE ANY COLLECTED DEBRIS REMAINING FROM INSTALLATION**



Watts AS-MB  
Microbubble Air Separator

### PEX Brass Crimp Fittings

#### Friction Loss - Equivalent Feet of PEX Tubing

Size	Coupling	Elbow	Tee Run	Tee Branch
3/8"	2.9	9.2	2.9	9.4
1/2"	2.0	9.4	2.2	10.4
3/4"	0.6	9.4	1.9	8.9
1"	1.3	10.0	2.3	11.0

## GRUNDFOS UPMXL 25-124 230V PWM

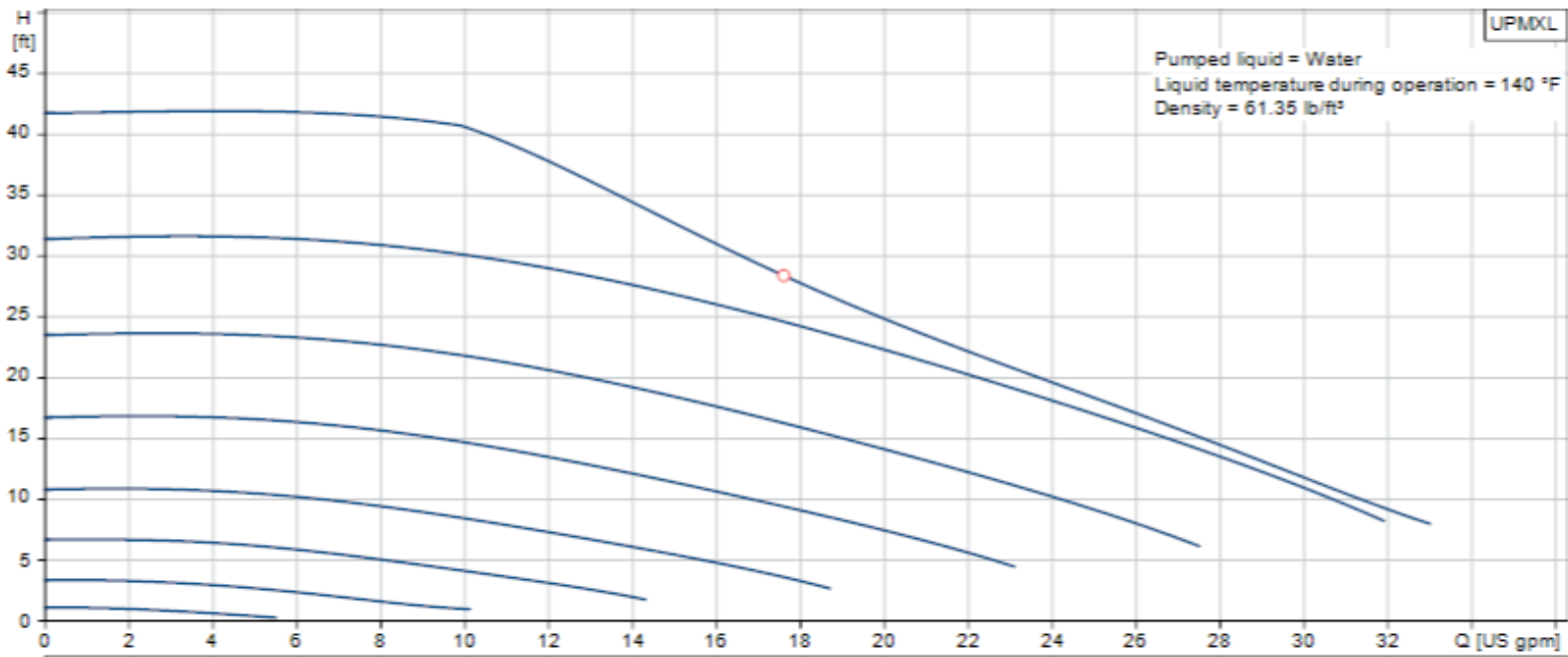

This is the Grundfos pump head curve for Chiltrix CX50 and is shipped with 2022 and newer CX50 units.

Note, the CX50 itself has 16 Ft. Head at 10 GPM.

This leaves about 24 ft of head net of the chiller.

Below is a chart to multiply head loss based on glycol percentage. Multiply the ft. of head available according to the chart above by the factor below, based on the amount of glycol in your system.

Glycol %	Pump Head Derate Factor
0	1
10	.95
20	.91
30	.86
40	.79
50	.73
60	.68

# Glycol

While not always required, customers in colder climates that are subject to occasional freezing should add an appropriate percentage of food-grade propylene glycol to the system. **NEVER USE ETHYLENE GLYCOL.** Ethylene Glycol is a poison. Propylene Glycol is a non-toxic anti-freeze also used in food, cosmetics, etc. and can safely be used. **IF YOU ARE IN AN AREA THAT MAY HAVE <32 °F WEATHER YOU SHOULD CONSIDER GLYCOL. FREEZE DAMAGE IS NOT COVERED UNDER WARRANTY.**

Food-Grade Glycol is available at Home Depot and other retailers. You may also consider HSE Corn Glycol (Biodegradable Food-Grade Glycol made From Corn)  
<https://www.hotspotenergy.com/corn-glycol/>

Below is a Freeze Point Chart For Propylene Glycol Mixed w/ Water

		Freezing Point						
Propylene Glycol Solution (%)	by mass	0	10	20	30	40	50	60
	by volume	0	10	19	29	40	50	60
Temperature	°F	32	26	18	7	-8	-29	-55
	°C	0	-3	-8	-14	-22	-34	-48

## Flow Rates

### Required flow rate changes with the glycol %.

Note the “500” formula water factors are adjusted as follows (based on 2,3 tons capacity) based on 10F ΔT.

00% glycol use  $500 \frac{24,000}{500/10}=4.8$  GPM  
 10% glycol use  $494 \frac{24,000}{494/10}=4.85$  GPM  
 20% glycol use  $488 \frac{24,000}{488/10}=4.91$  GPM  
 30% glycol use  $480 \frac{24,000}{480/10}=5.00$  GPM  
 40% glycol use  $463 \frac{24,000}{463/10}=5.18$  GPM  
 50% glycol use  $442 \frac{24,000}{442/10}=5.43$  GPM

00% glycol use  $500 \frac{36,000}{500/10}=7.42$  GPM  
 10% glycol use  $494 \frac{36,000}{494/10}=7.28$  GPM  
 20% glycol use  $488 \frac{36,000}{488/10}=7.37$  GPM  
 30% glycol use  $480 \frac{36,000}{480/10}=7.50$  GPM  
 40% glycol use  $463 \frac{36,000}{463/10}=7.77$  GPM  
 50% glycol use  $442 \frac{36,000}{442/10}=8.14$  GPM

### NOTE:

When using **CPVC piping** it is highly recommended that you do not exceed a 25% glycol to water ratio. Environmental Stress Cracking, also referred to as ESC, may occur. Do NOT use PVC piping.

Example:

Based on load calculations a given system needs to deliver a maximum of 31,000 BTU with 30% glycol:  
 $31,000/480/10=6.46$  GPM  
 (BTU/water factor=required flow rate)

Use the required flow rate to calculate head based on the Head Flow Curve on the following page.

Minimum pump operating speed can be set at P53, minimum speed setting used should not produce a flow rate in your system of less than 14 L/min and generally should not be set lower than 40%. Pump speed can be monitored at C48, 1 is lowest (idle, when compressor off) and 10 is highest speed. Actual water flow can be monitored on the desktop and at C13, liters per minute. **Test at full pump speed.** 1 L/min = .264 GPM // 1 GPM = 3.78 L/min

### IMPORTANT NOTE IF YOU DO NOT USE GLYCOL

if you must drain a no-glycol unit for the winter use the ½” drain valve and air vent at the top of the heat exchanger. Then use a container of 50/50 premix food grade colored RV glycol held up above the level of the CX unit (can be on top of the unit and let it flow into the water inlet pipe until you see it come out the outlet pipe pipe).

# Chiltrix Heat Pump Installation

## Heat Pump Installation

### Installation position

**Note: Installation must be carried out by professional personnel.**

The recommended mounting pad should be at least 1 ½” above ground level. If you are in an area where snow occurs, mount the unit high enough above grade to avoid blockage by drifting snow. You can consider a properly rated wall mount if desired.

Proper drainage is required at the heat pump unit to avoid flooding the outdoor unit with water or ice. Make sure condensate has a way to rapidly and completely drain away from the unit.

To install the unit on a balcony or on top of a building, the installation site must meet the allowable load bearing capacity of the building structure without affecting the structural safety. Ensure the unit is well ventilated; the direction of air exhaust should be kept away from the windows of neighboring buildings.

Adequate service clearance should be kept around the unit. The unit should not be installed in places accompanied with oil, inflammable gases; corrosive components e.g. sulfur compound, or high-frequency equipment.

**No obstacle in front of the unit**

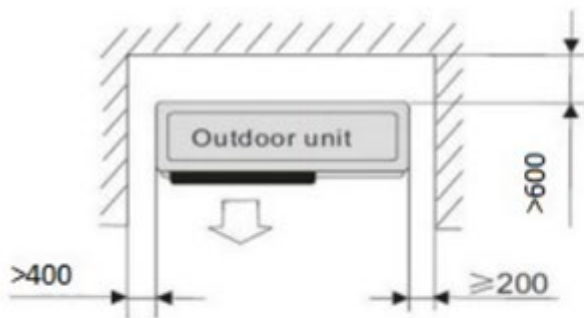

**Obstacle above the unit**

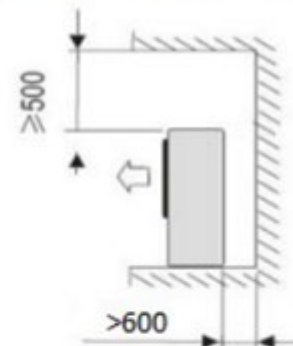

**Obstacle in front of the unit**

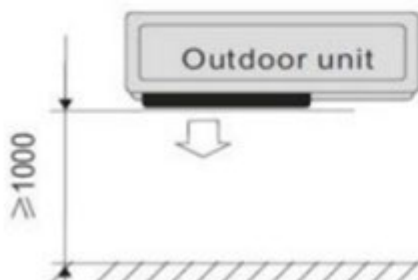

**Several units in a row**

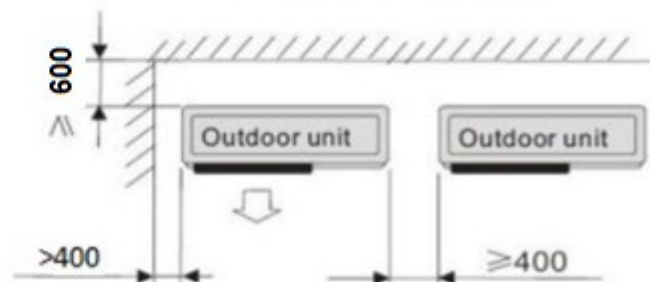

**Outdoor Unit Placement / Clearances**  
 (Unit: mm) 200mm = 8” , 350mm =14” ,  
 400=16”, 500=20”,600 = 24”,1000=40”

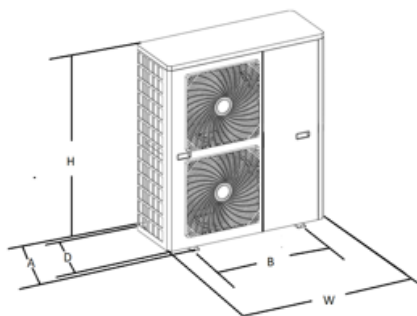

Dim	Inches
A	17.5
B	29.5
D	17
H	50
W	44.5
W Inc Fan Shroud	18

### More about Location:

You don't want it in a "pit" or enclosed area where air flow could be impaired or where fan output could be prevented from rising away in summer, or could stratify cold output in the heating season and cause an artificial drop in ambient temp.



## Chiltrix Heat Pump Installation

**NOTE:** The cx50 is shipped with the pump in a separate box attached to the top of the chiller. Please follow the directions below to install the "C4" Grundfos internal pump.

There is a factory installed spacer that is to be removed.

### Internal Pump Installation

(Remove Top, Front, and Right Side Covers) **DO NOT BEND OR STRESS THE PIPING, this may cause a broken joint or leak where it joins the heat exchanger.** Cut the insulation and peel it back out of the way of the flange nuts. This will allow installation of the pump without bending either of the pipes. The pump will slide in between the pipes with the washers.



Peel back the insulation



Removing the shipping spacer

Remove the pump spacer and install the pump here



Note the orientation.

If you have ordered a special pump, for example a stainless steel model that is to be installed outside of the Chiltrix cabinet, leave the spacer intact (but check to make sure it is tight as it may only be finger-tight from factory).



## Internal Pump Wiring

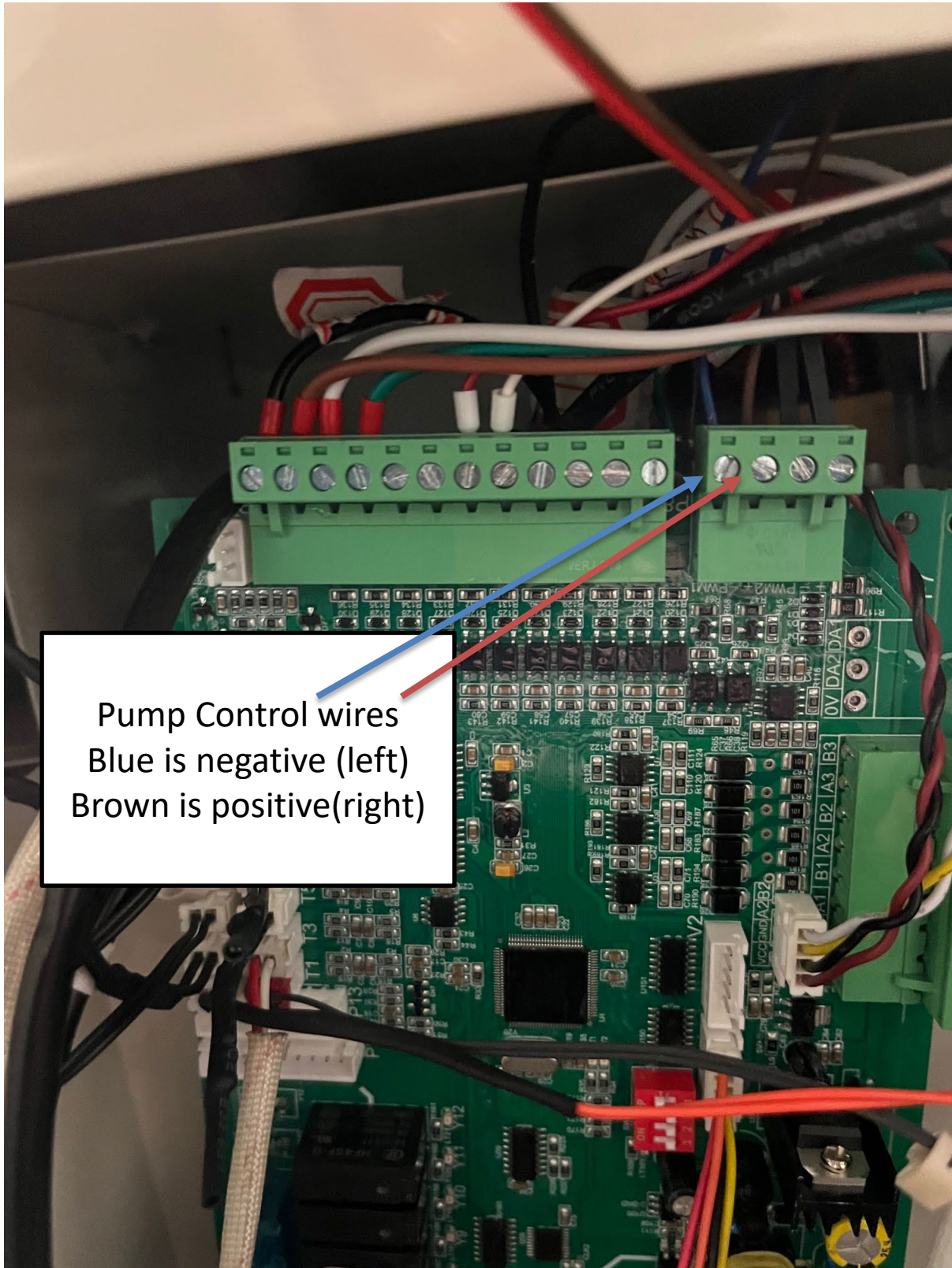

Pump Control wires  
Blue is negative (left)  
Brown is positive(right)

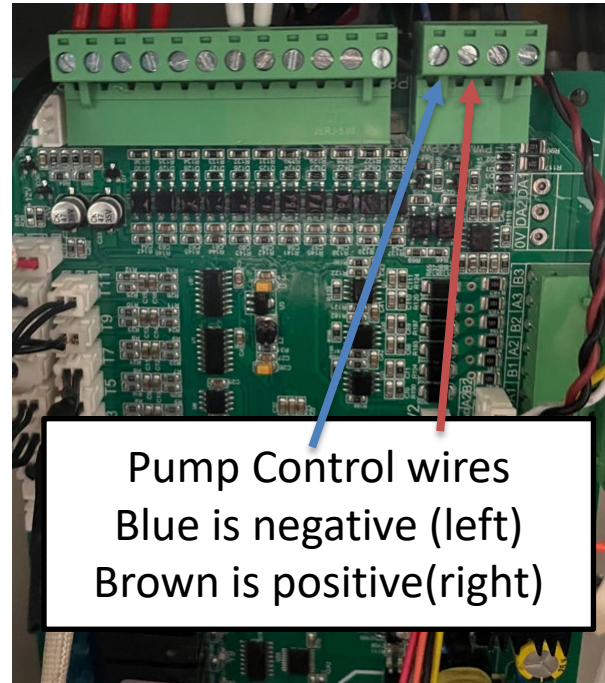
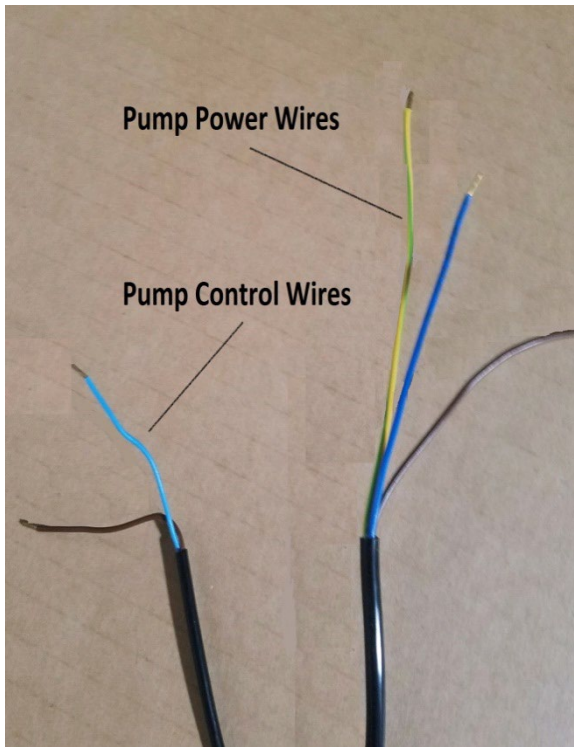

The blue and brown pump **CONTROL WIRES** are connected to the (+ & -) on the Pump PWM terminal connector at the top of the main control pcb.



Pump **POWER** wires.

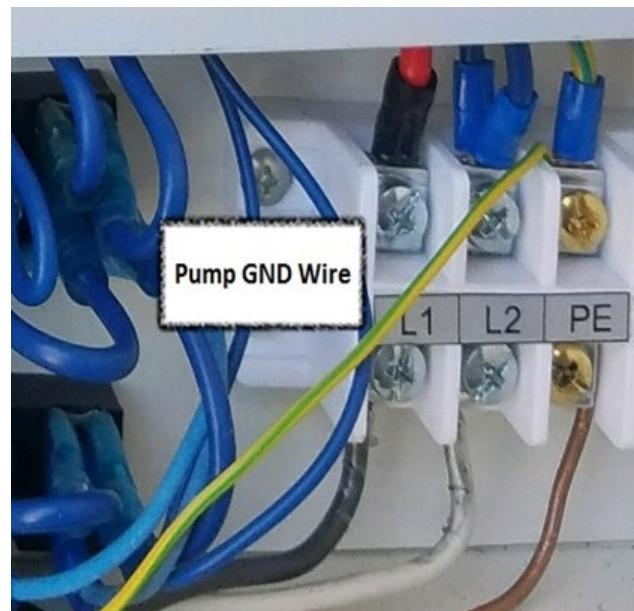

Pump **GROUND** wire.



## Stainless Steel Pumps

**Option:** if the chiller was ordered with a stainless steel pump labeled “Taco Comfort Solutions 0034e” then the pump control logic will need to be changed using parameter P23. If you have the stainless steel pump “0034e”, set parameter P23 to “1”. This pump will be placed external of the cx50. The Taco Pump 0034e will also be placed outside of the unit but P23 will remain “0”. Otherwise if you got the factory style pump that threads into the unit as shown above then leave P23 “0”.



Note: The stainless steel pumps will also come with a flange kit. If you order the 0026e (cx35) the flange threads are 1” NPT. If you order the 0034e(cx50) then the flange threads are 1-1/4” NPT.



## Electrical Connection

### General

#### **Note!**

***Electrical installation and service must be carried out under the supervision of a qualified electrician. Electrical installation and wiring must be carried out in accordance with the NEC.***

The heat pump must be connected under the supervision of a qualified electrician. Wires, spare parts and materials etc. must satisfy the relevant standards and codes issued by the host country or region. The heat pump does not include an AC disconnect or switch on the incoming electrical supply which will be required. The power supply cable must be connected to a circuit-breaker with at least a 3 mm breaking gap. Incoming supply must comply with the technical requirements, with a frame ground wire (neutral is not used), via a distribution box with breakers. **Allowed Voltage range is 208-240vac. Maximum wire size must be suitable to your code and meet NEC requirements, breaker size is 30 AMP, for the cx50.**

It is the responsibility of the customer to provide clean power, 208-245v 1P 60Hz without power surges. It is advisable to add surge suppression with transient voltage protection to the circuit powering the heat pump. Clamping voltage of the device should be less than 400v.

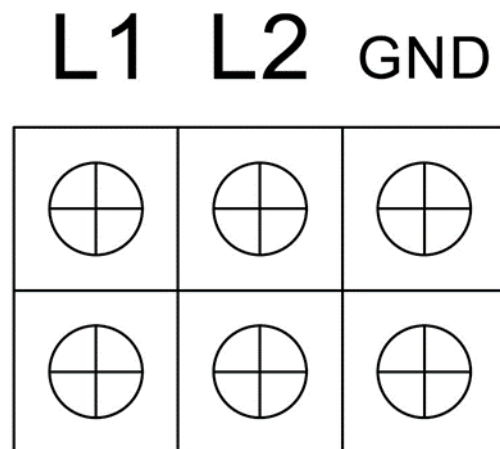
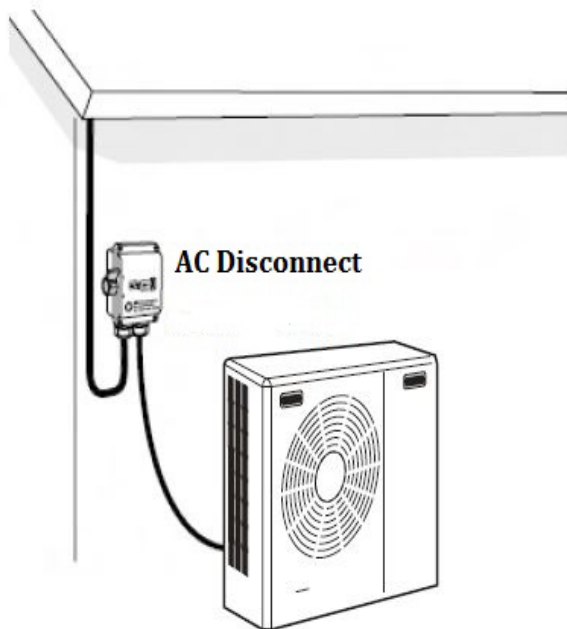

Main terminal block inside electronics box

Example MOV transient voltage suppressor

<https://www.mouser.com/?Keyword=V300LA40AP>

# Electric Connections and Component Locator

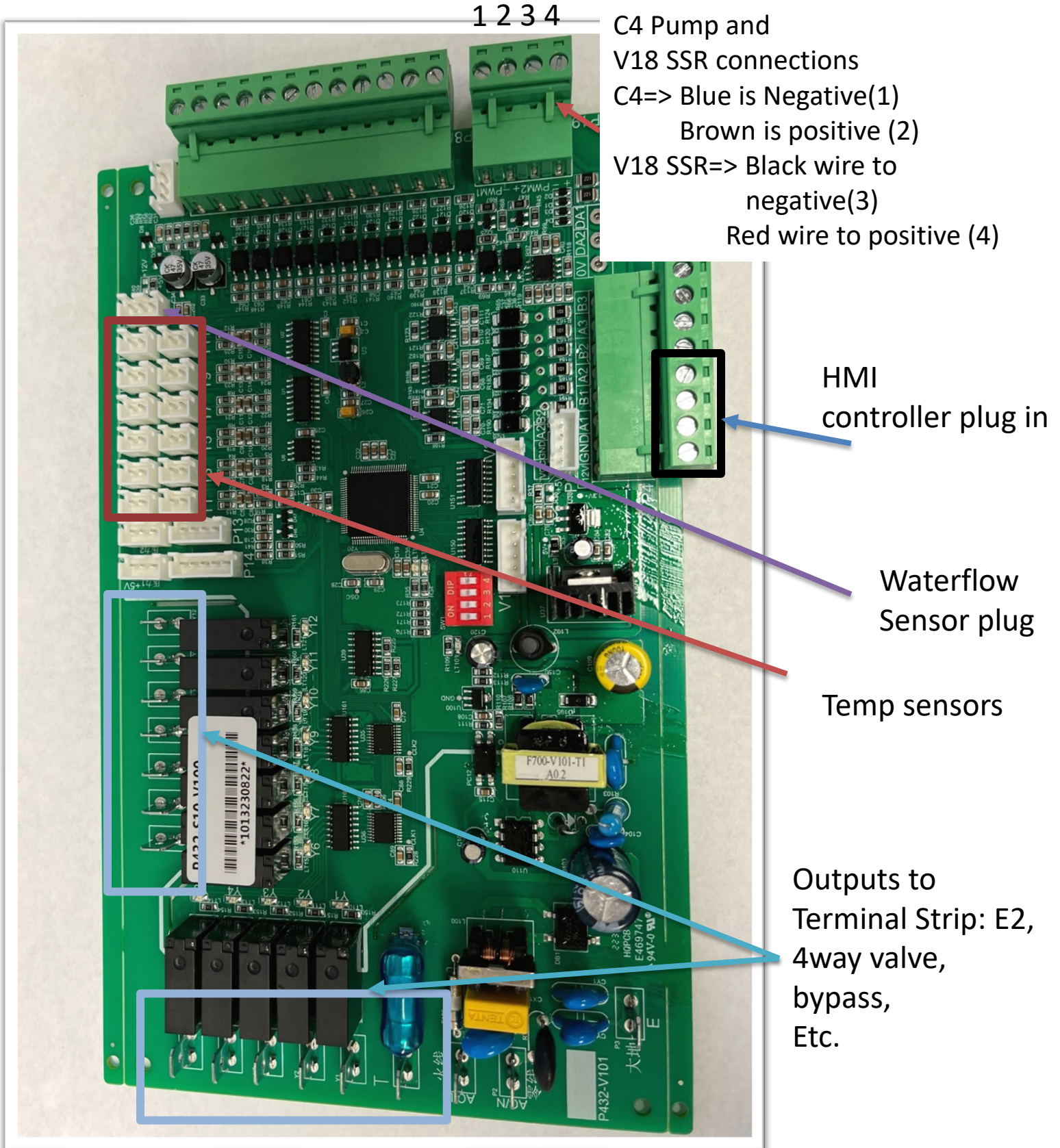





## When using a second NON-PWM water pump

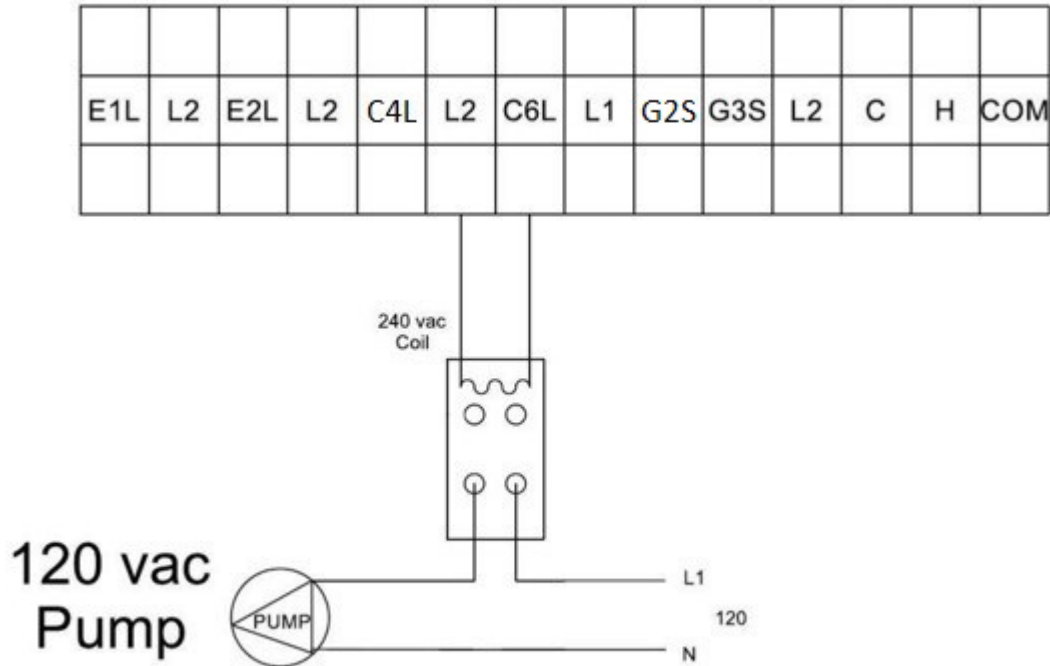

Connect the fixed speed pump to L2 and C6L.

**When using a second NON-PWM water pump, use terminals L2 and C6L for relay coil power only. Do not connect a pump directly to L2 and C6L, always use a relay with a 240 vac coil. This pump will only run when the PWM pump is running. Setting P52=0, and P54=1, will shut C6 off when the chiller reaches its set point.**

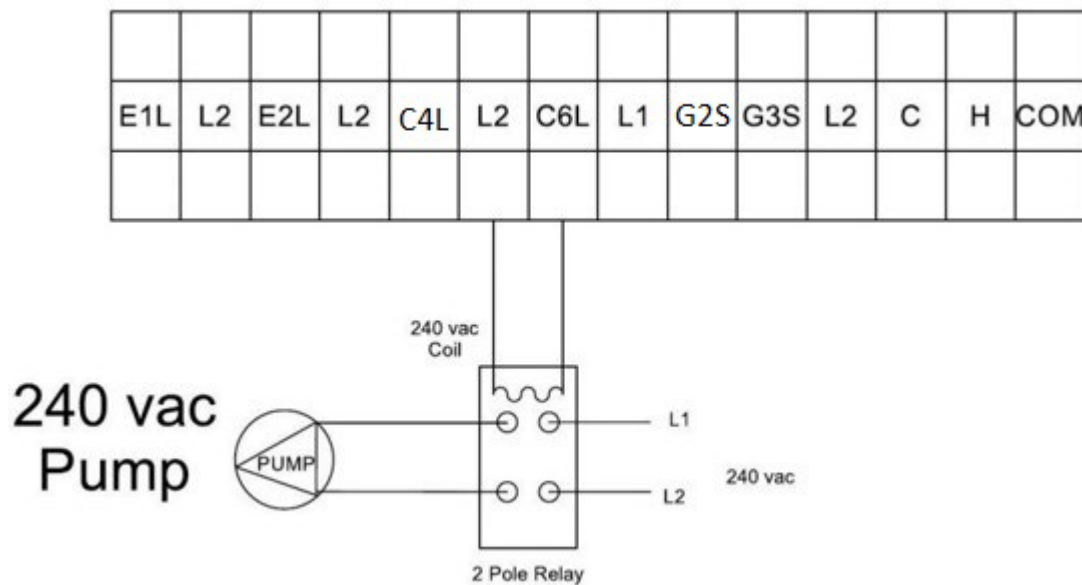



## DHW (Domestic Hot Water) G2 Valve

G2: DHW/AC / Heating 3-Way Valve

In DHW mode, the G2 valve is powered off. In AC/heating mode, G2 is powered on. Parameter P08 must be "0" to enable DHW.

**Status Indication:** G1 will be displayed yellow while DHW mode is active, G2 will be displayed yellow when heating/cooling is active. NOTE: please see the difference in displays on page 34 as they changed for software version 108.1 and newer.

**G2 and G3 valves use 220v Primary from the cx50. Use conduit and install per local code.**

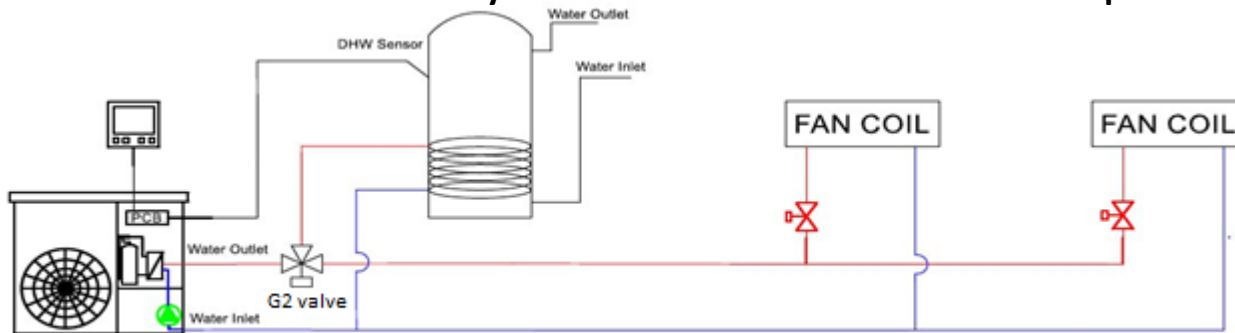

PLEASE MAKE SURE TO CONSULT THE CORRECT VERSION OF THE TANK MANUAL FROM THE CHILTRIX DOCUMENTS PAGE

<https://www.chiltrix.com/documents/>

DHW target setting temperature is the tank water temperature measured with the DHW sensor, not the cx50 inlet water temperature. If the target temperature is 120°F, and the differential is 2°C, it means, when the DHW tank reaches 120°F, the compressor will stop. When the DHW tank temperature is lower than 116°F, DHW will start. **See the Chiltrix Tank Manual before proceeding to install or connecting any DHW or buffer tank.**

**See the Chiltrix Tank Manual for important details and options for using cx50 with DHW, including backup heat options, and anti-legionella function. READ THE CHILTRIX TANK MANUAL BEFORE DESIGNING, CONNECTING, CONFIGURING, OR USING DHW.**

The indoor ambient air temp is not used at this time, however, **do not disconnect this sensor. Leave all unused sensors plugged in and wrapped in the bundle above the compressor.**

### IMPORTANT

Check all tank ports including under any element covers to make sure any unused ports are plugged. Pre-plugged ports may be only finger-tight. Check ALL ports and plugs for water tight fit.

Note; There is a clear plastic bag taped to the cx50. It contains the mounting feet, DHW sensor, and controller cable. Controller is inside.



## DHW (Domestic Hot Water) G2 Valve

### DHW and AC / Heating with two chillers in Parallel

G2 and G3 valves use 220v Primary from the cx50. Use conduit and install per local code. Below shows 2x heat pumps set up so that Chiller 2 can continue to provide cooling or heating while Chiller 1 deals with any DHW load. Bottom drawing shows 1x cx50 with DHW.

The G2 valve should be installed as close to the cx50 as practical. The DHW tank should be installed as close to the G2 valve as practical. Shorter distances will improve performance and reduce the likelihood of needing a booster pump. It is best if the cx50 can be located within 30 ft. of G valve, which should be within 30 ft. of the DHW tank.

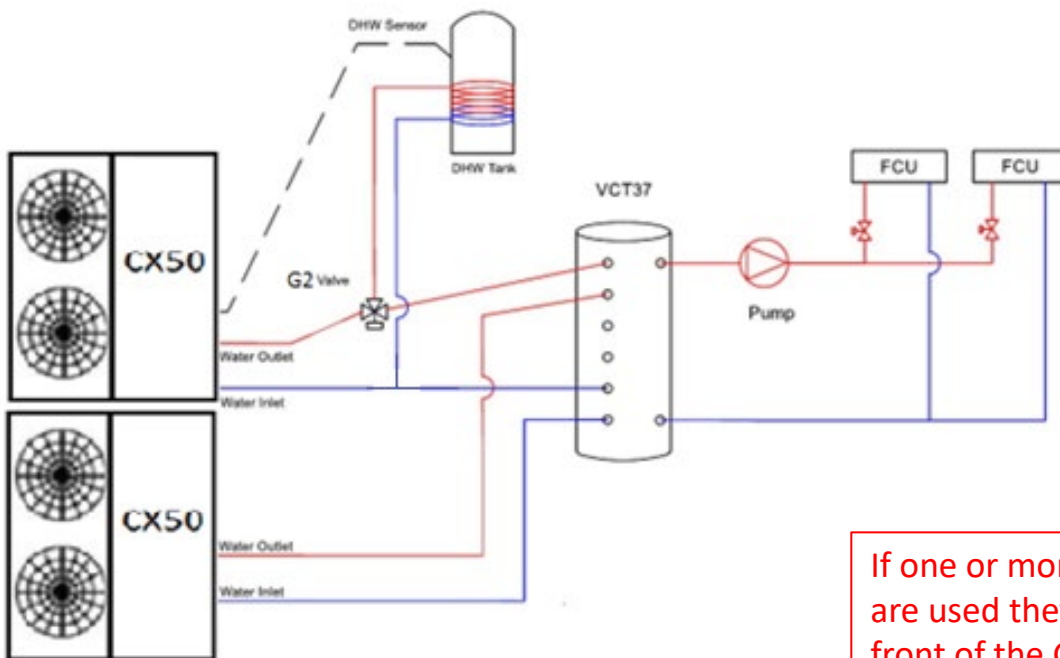

If one or more V18b units are used they must be in front of the G2 Valve (upstream from G2) See V18b manual.

**IMPORTANT**

Check all tank ports including under any element covers to make sure any unused ports are plugged. Pre-plugged ports may be only finger-tight. **Check ALL ports and plugs for water tight fit.**

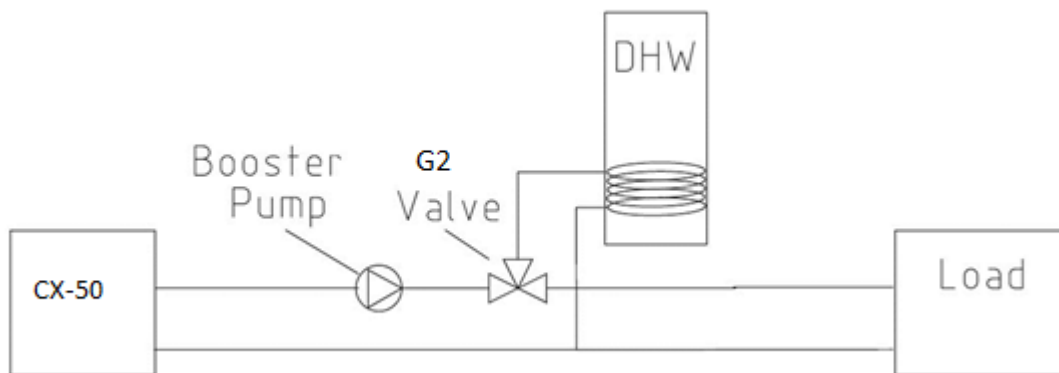

Any booster pump should be located between the heat pump outlet and any G2 valve or V18

## G valves Continued

A booster pump may be installed in front of the G2 valve when installing the DHW option if the head, including pressure drop of the DHW tank coil, exceeds the head allowed by the pump curve when calculated at 7GPM. If a booster pump is needed for a different reason, this location should also be used. Check the DHW tank pressure drop from the Chiltrix Tank Manual or tank provider coil specs if not using a Chiltrix tank. The G2 valve should be located as close to the cx50 as practical.

**G2 Valve Wiring** Note; The G2 control wire is connected to G2 on the terminal strip G2 and G3 valves use 220v Primary from the cx50. Use conduit and install per local code.

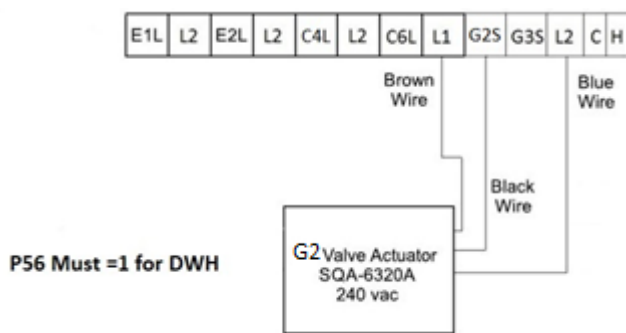

If one or more V18b units are used they must be in front of the G2 Valve (upstream from G2) See V18b manual.

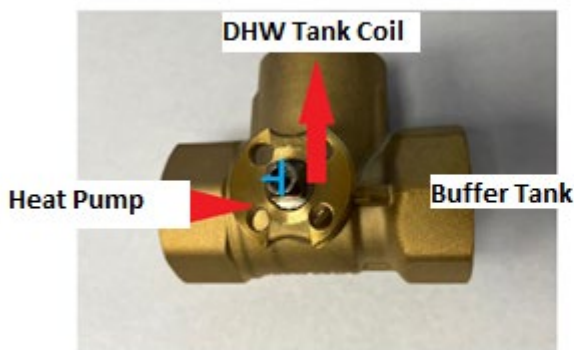

**Figure 1**  
DHW MODE

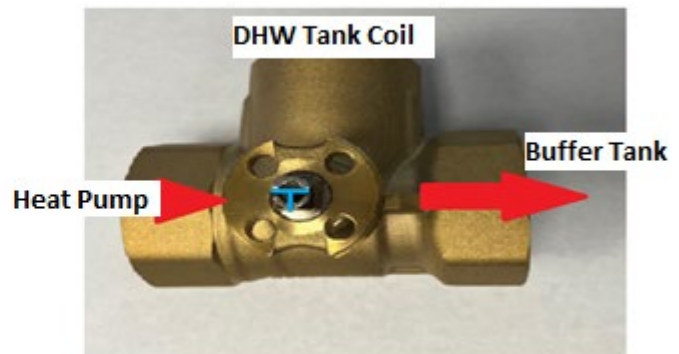

**Figure 2**  
Heating and cooling mode

Figure 1, this is the direction of flow when it is activated for DHW. Figure 2, this is the direction of flow when it is activated for Heating or Cooling. When the brown wire is connected to L1, the blue wire connected to L2, and the black control wire is connected to G2S the valve is controlled by voltage at L2 and G2S. Voltage at G2S activates the valve for DHW. No voltage at G2S activates the valve for Heating/Cooling. See wiring diagram above. **In order to position the dhw actuator in the correct position. You will need to turn the dhw valve to match figure 2. Connect the wires as show above and place the actuator to the side next to the dhw valve. With dhw mode off IE: the unit is in heating or cooling only. Turn the cx50-2 on and let the unit run for a few seconds, the actuator may or may not move depending on how it was built at the factory and what origin point the stem is in, after about 2 mins of the unit running you may place the actuator on to the dhw valve and tighten down to its final position. Verify that the dhw and heating/cooling is working.**

## G valves Continued

Note: the DHW valve is Straight thread, there will be 3 of these adapters per valve. This adapter adapts the straight thread to 1 1/4" npt.



## G3 Valve: Seasonal Switch Valve

G2 and G3 valves use 220v Primary from the cx50. Use conduit and install per local code.

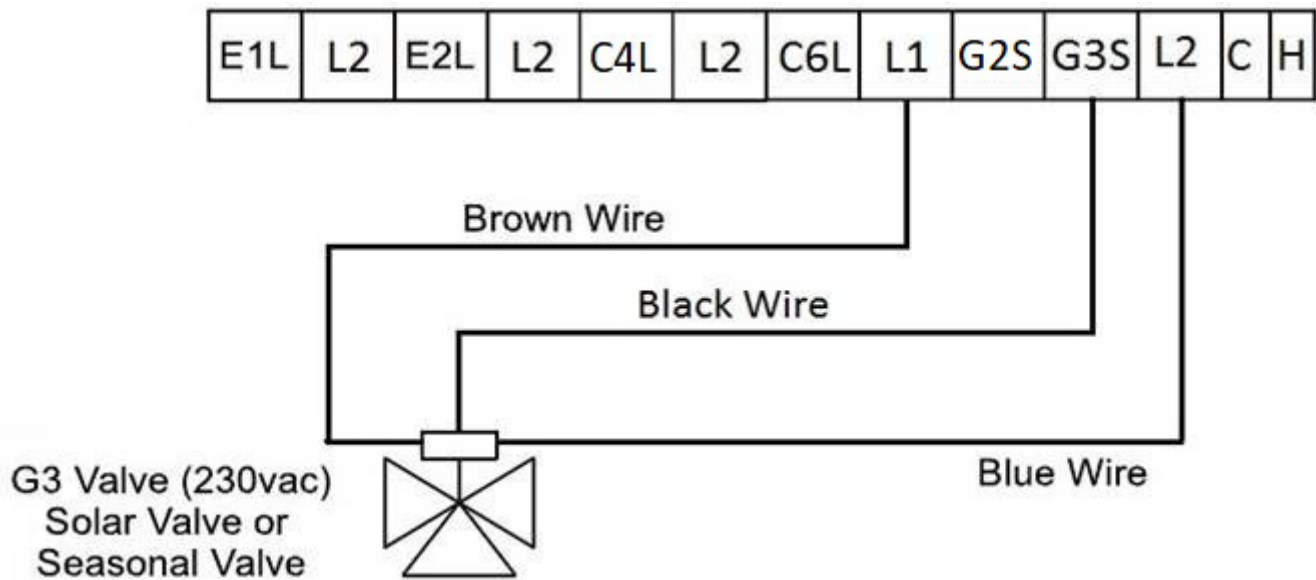

The G3 port can be used to control a seasonal switch valve. The seasonal switch valve is used to isolate the floor coils from the fan coils when switching over from heating to cooling. The seasonal switch valve is controlled by parameter P50. When parameter P50 is 0, the valve is configured as a seasonal Switch.

When parameter P50 is 1, the valve is configured as a solar pre-heat valve. The cx50 compares the solar tank temp and AC returned temp. When the solar tank temp – AC returned temp is  $\geq 5$  °C, the 3-way valve G3S will be on; when solar water tank temperature minus the air conditioning returned temperature is less than 2°C, G3S will be off.

# G3 VALVE

## Seasonal Switch Valve

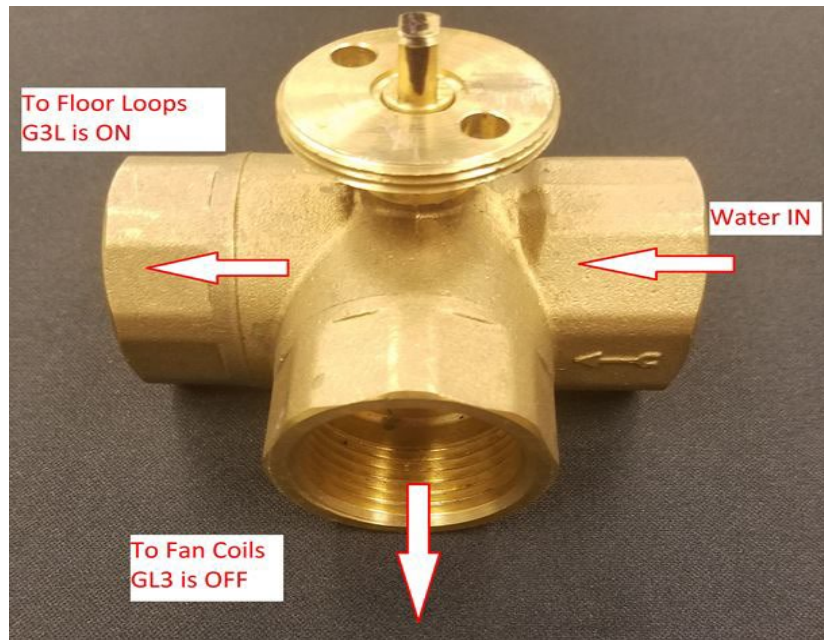
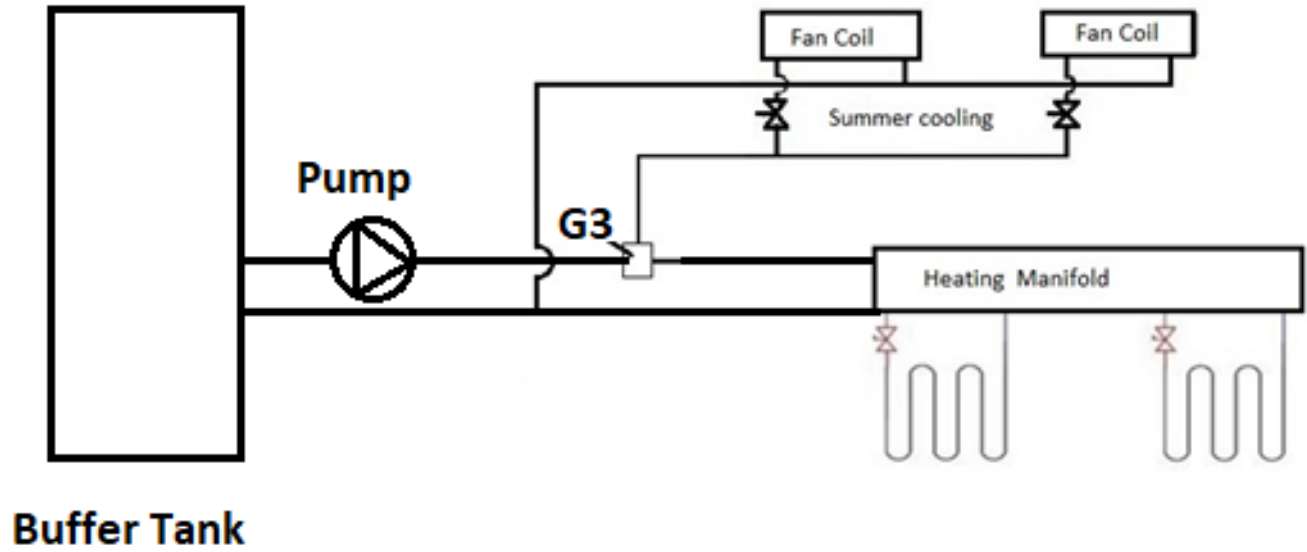

**G3 Ports**



## Second Heat Source

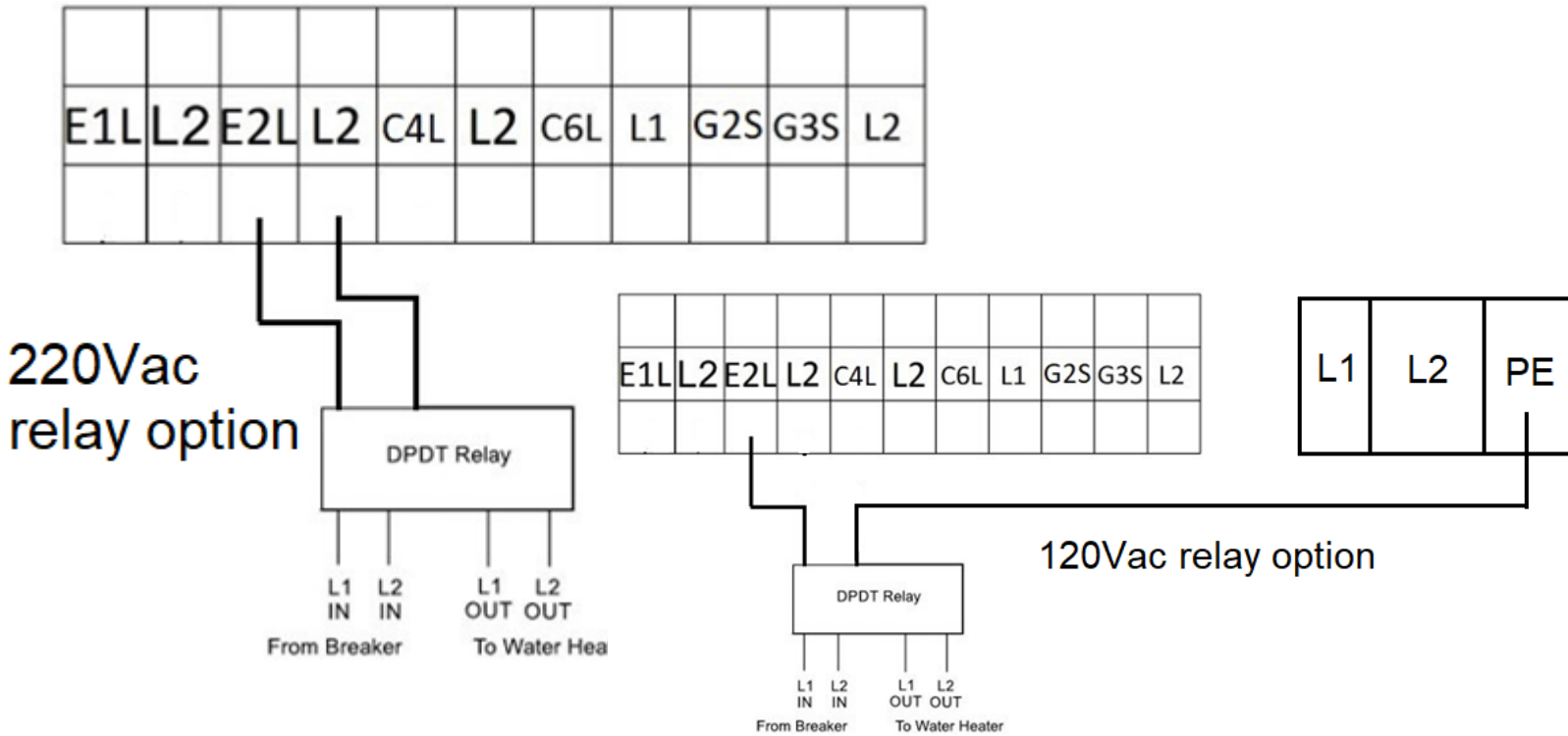

- P56 value=0 is for when using dynamically variable SSR output to a V18.
- P56 value = 1 is for when using a relay on the E2 terminals to start a 2<sup>nd</sup> heat source such as a boiler.
- P56 value = 2 is for when no backup heating is used or being controlled by the chiller.
- If no backup of any kind is used, change it to 2.
- DO NOT USE ELEMENTS IN A BUFFER TANK FOR BACKUP HEATING. SEE CHILTRIX TANK MANUAL. Elements would be used in a buffer tank for \*emergency heat\* not for backup heat.
- NOTE\* THE PREFERRED WAY TO ADD BACKUP HEAT IS TO USE THE CHILTRIX V18 DYNAMIC VARIABLE BACKUP HEATER. "SECOND HEAT SOURCE" IS AN OLDER AND MORE COMMON METHOD, BUT IS NOT AS EFFICIENT AS A V18.
- P57 is E2 activation air temperature. Outdoor air temp must less than P57 for E2 to be activated. P57 default is 0°C (P57 range is -20~20°C)  
P40= the E2 start delay time. If compressor cannot meet target for X minutes then E2 will start.



## Onboard External Relay Control

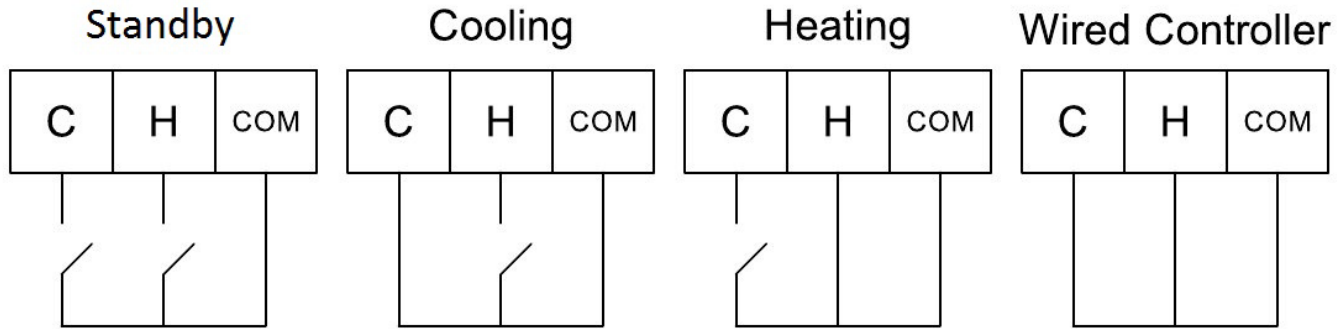

Above shows the C-H-COM terminals logic.

**IMPORTANT:** The C,H, Com terminals are DRY CONTACTS. Do NOT apply Voltage to the terminals.

This optional feature allows you to control the mode (heating or cooling, standby) of the Chiltrix heat pump from a standard single stage heat pump thermostat. There are two options explained below, with instructions, drawings and configuration settings on the next page.

### Option 1 (This is the one that's most commonly used)

With this option, a standard single stage heat pump thermostat can be used to select the cool-heat-off (standby) mode of the heat pump. When the thermostat makes a call for heating or cooling the compressor starts with the reversing valve in the correct position, according to the mode you have set on the thermostat, and will target the user-defined preset tank target temperature. Note, this option does not maintain a temperature in a buffer tank between calls so the tank temperature may drift from target if it has been a significant amount of time since the last call. However, after a short thermal lag the target tank temperature will be restored.

### Option 2

This option leaves the heat pump in its last used operating mode, the heat pump continuously monitors the buffer tank temperature, running the compressor at a variable speed to replace any standby losses as they occur, maintaining the tank at the target temperature. With this mode, the thermostat selector can only chose heating or cooling. To turn the system off, you would select off at the thermostat and then also use the Chiltrix controller to stop the heat pump. This option eliminates any thermal lag caused by standby losses.

Either of the above options allow a standard single stage heat pump thermostat or other external controller to control switching the heating, cooling (and it option 1, standby) modes of the heat pump via relay. This method of control generally requires a single-stage standard heat pump thermostat, a installer provided 24 vac transformer and two relays, (Eg. Tyco K10P-11A15-24, w/ two relay sockets, 27E487). The relays can be located in the chiller next to the IPM. The transformer can be located in the home near the standard thermostat or other controller.

# Onboard External Relay/T-Stat Control

**NOTE:** Before removing any jumper or connecting any relays, make sure of the following:

1. Enable/disable DHW, as applicable, at P08. Your selection will follow along with a change between heating and cooling. If DHW is active (Parameter P08=0) DHW will work even when external relay control has the system “off” (standby).
2. Use the controller Mode button to switch modes and set the target temperatures of each mode Heat, Cool and DHW, before proceeding.
3. Auto-switchover (based on outdoor temp) at P42/P43 cannot be used when using this feature.
4. In order to use this function you must enable P111.

**IMPORTANT:** The C,H, Com terminals are DRY CONTACTS. Do NOT apply Voltage to the terminals.

## OPTION 1 (NO Relays)

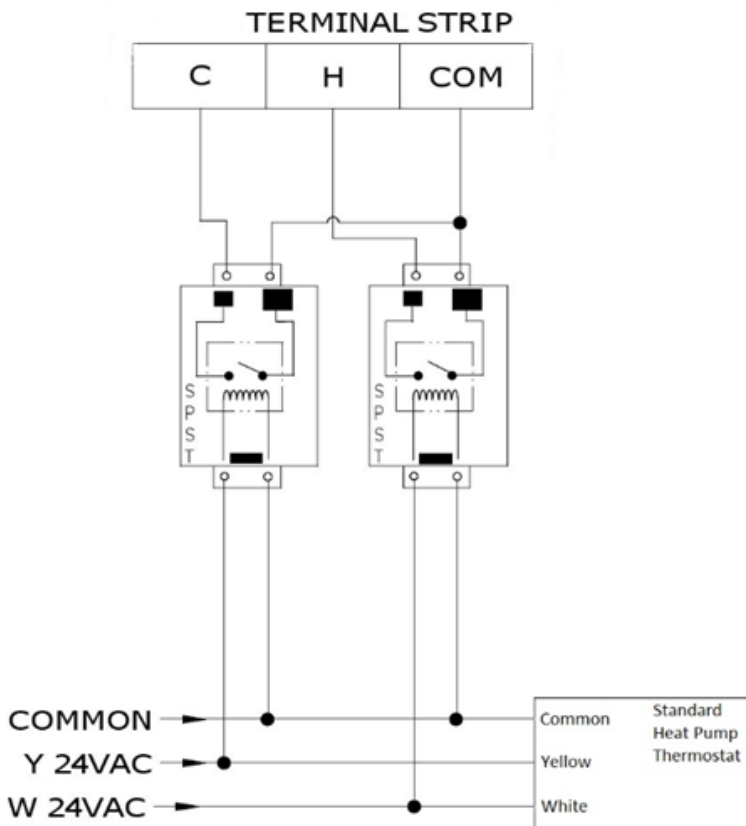

## OPTION 2 (NC Relays)

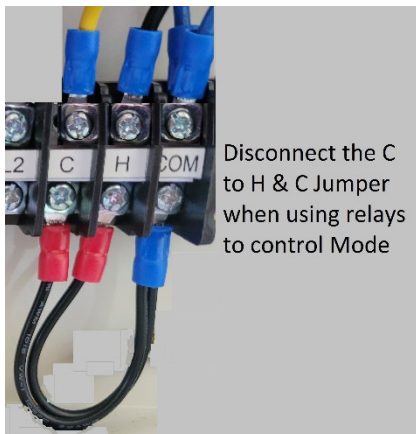
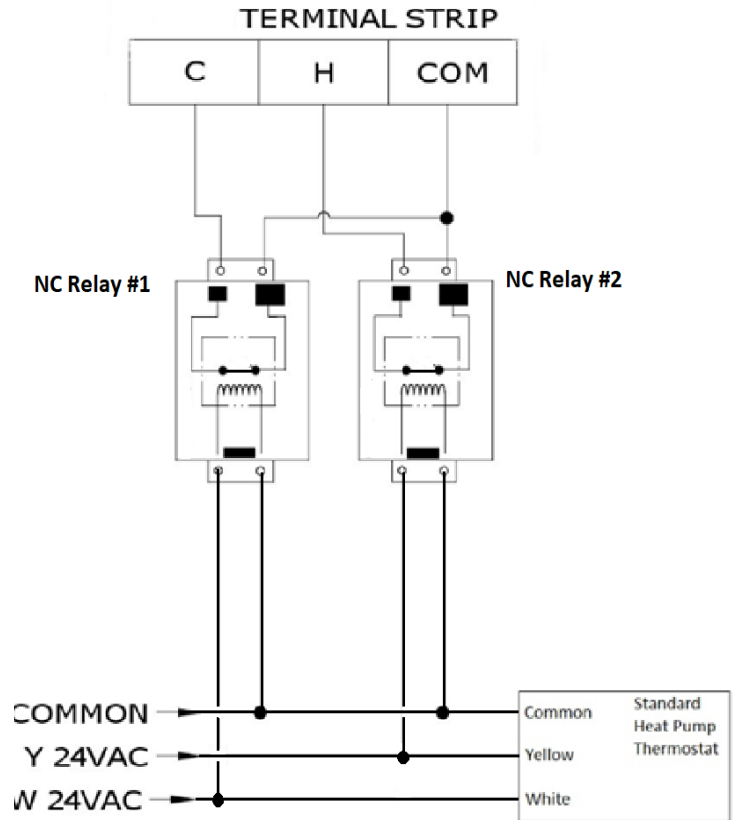

The switch status can be displayed in the C parameters  
 C63 is X06 AC heating switch mode status; 0=OPEN; 1=CLOSE  
 C64 is X07AC cooling switch mode status; 0=OPEN; 1=CLOSE

**NOTE:** Using this relay control option will NOT override inputs from the Chiltrix standard wired controller unless p111 is enabled. See the Psychrologix manual for important additional information if this applies to you. Timers as explained elsewhere in this manual will NOT be available when relay control is used.

## System filling with Propylene Glycol and water

At or near the cx50 a flush/fill valve assembly must be installed. This can be made with three ball valves and a couple hose fittings. If you don't already have a fill kit for use with solar thermal, hydronic, or chiller systems, you can easily create one with the following Bill of materials: All Pex fittings are available at [www.supplyhouse.com](http://www.supplyhouse.com)

2 ea. Pex 1" x 3/4" Tee SKU: H051175LF Brand: Rifeng

1 ea. Pex 1" Ball Valve SKU: H081000LF Brand: Rifeng

2 ea. Pex 3/4" Ball Valve SKU: H080750LF Brand: Rifeng

2 ea. 3/4" Hose Fitting SKU: G20103 Brand: Jones Stephens

2 ea. Pex 3/4" x 3/4" NPT Female Adaptor SKU: H040750LF Brand: Rifeng

10' of Garden Hose Home Depot

5 Gallon Bucket Home Depot

High Head Fill Pump Grainger

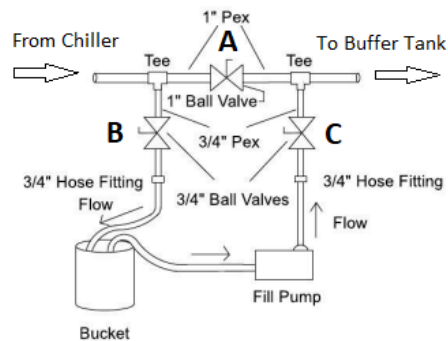

Pre-mix the propylene glycol in a container large enough to hold the loop volume plus a few gallons. Using a filling pump and 3 hoses, place one hose in the glycol container and connect it to the suction side of the pump. Connect the second hose to the pump discharge and the other end to valve "C" that is closest to the fan coils. Using a third hose, connect it to valve "B", closest to the chiller and leave the open end in the glycol bucket. Close the middle ball valve "A". Close the middle ball valve "A". The pump should be pumping away from the Cx50 chiller. Open and close valve "A" a few times to remove trapped air. The pump should be pumping away from the CX50 chiller.

Run the pump until there are no more air bubbles coming out of the loop. After all air is expelled from the loop, close valve "B" and then open valve "A" with the pump running. When the pressure gage on the cx50 shows at least 30 psi close valve "C" and turn off the pump. Minimum loop pressure is 14.5 psi, maximum pressure is 43.5 psi, and ideal pressure is 20-30 psi.

See more info on Isolation valves used with the flush fill system here <https://www.chiltrix.com/documents/Charging-Fill-Kit.pdf>

## Purging Air From DHW Tank & Fan Coils

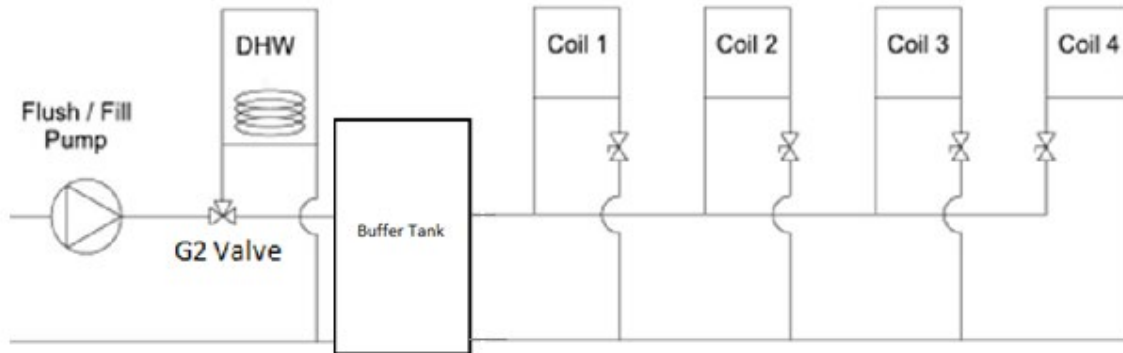

If a DHW tank is installed, the G valve should be the first device on the loop as shown, unless there is a V18 (which would always be in front of the G valve). The G2 valves should always be as close to the cx50 as possible. The tank should be as close to the G2 valve as possible.

To purge the air from its coil, remove the actuator from the valve body and rotate the valve stub 90° clockwise to force the water through the coil. Return the valve stub back to its original position when all of the air is purged. Close the input valve to each fan coil except the first coil (1). Turn the pump on and run it, when the bubbles stop coming out of the discharge hose turn on the ball valve on coil (2), wait for the bubbles to stop, then do the same for coil number (3), then (4). All CX Chillers have a flow switch installed in the loop. Air in the system may cause a flow switch alarm; the controller will display a P05 error code.

All CXI fan coils have an air purge screw near the water inlet port, always purge the fan coils before starting the chiller. The cx50 chiller also has a bleeder valve with a ¼" clear tube attached to it located near the brazed plate heat exchanger.

### Fan Coil Flow Balancing (Performed at time of commissioning)

Proper and even flow through each fan coil is important for both heating and cooling. (Coil temperature can be displayed by pressing the up and down temperature arrow keys at the same time), This can be done with balancing valves or ball valves installed at each fan coil supply or return pipe. This must be done with the cx50 in heating mode, set loop AC target to the maximum temp setting for commissioning.

**DO NOT DO THIS IN COOLING MODE OR DAMAGE MAY OCCUR.**

Adjust valve positions until each fan coil has the same leaving fluid temperature, with all CXIs set to max manual fan speed and in heating mode. When all leaving fluid temps are the same, the units are properly balanced. If a fan coil is powered on but the fan isn't running, there is a good possibility that there is air trapped in that particular part of the loop. Also verify the parameters with the CXI FCU manual, page 34. <http://www.chiltrix.com/documents/Chiltrix-hydronic-FCU-ver-1.5.pdf>

Note – while only one ball valve per CXI is needed for balancing, best-practice would be to use 2 valves, one on supply and one on return, so that the fan coil unit could be isolated if needed.

**Standard Controller (Included with all cx50 Units)**

**Cooling, Heating, DHW, cooling + DHW, heating + DHW mode of operation options, automatic fault detection, alarm processing, and energy control.**

1. The 4-conductor control cable can be extended up to 300 feet of 20 AWG or larger.
2. The controller handles all input and output signals, and system status.
3. Full-touch color LCD display. **MUST BE INSTALLED INDOORS.**
4. Modes, set points and other factory parameter settings are entered directly on the LCD screen. Note, for heating and cooling, the set target refers to the return water temperature, in steady-state operation, the leaving temper will be +/- 5C (9F). The normal cooling set target is 53F which implies a leaving steady-state temperature of 44F. Heating, for radiant, is normally set for 86F (implies leaving at 95F). Heating, for fan coils, is normally set at 96F (implies steady-state temp of 104F). **The cx50 can achieve a leaving temp of 131F under most but not all conditions. The maximum supported target set point is 111F (implies a 120F leaving temp.**
5. 100 fault records can be stored and retrieved to show the details of each fault that may occur.
6. All of the switch input / outputs can be directly observed on the LCD control panel making commissioning convenient.
7. The LCD display is wall-mountable.

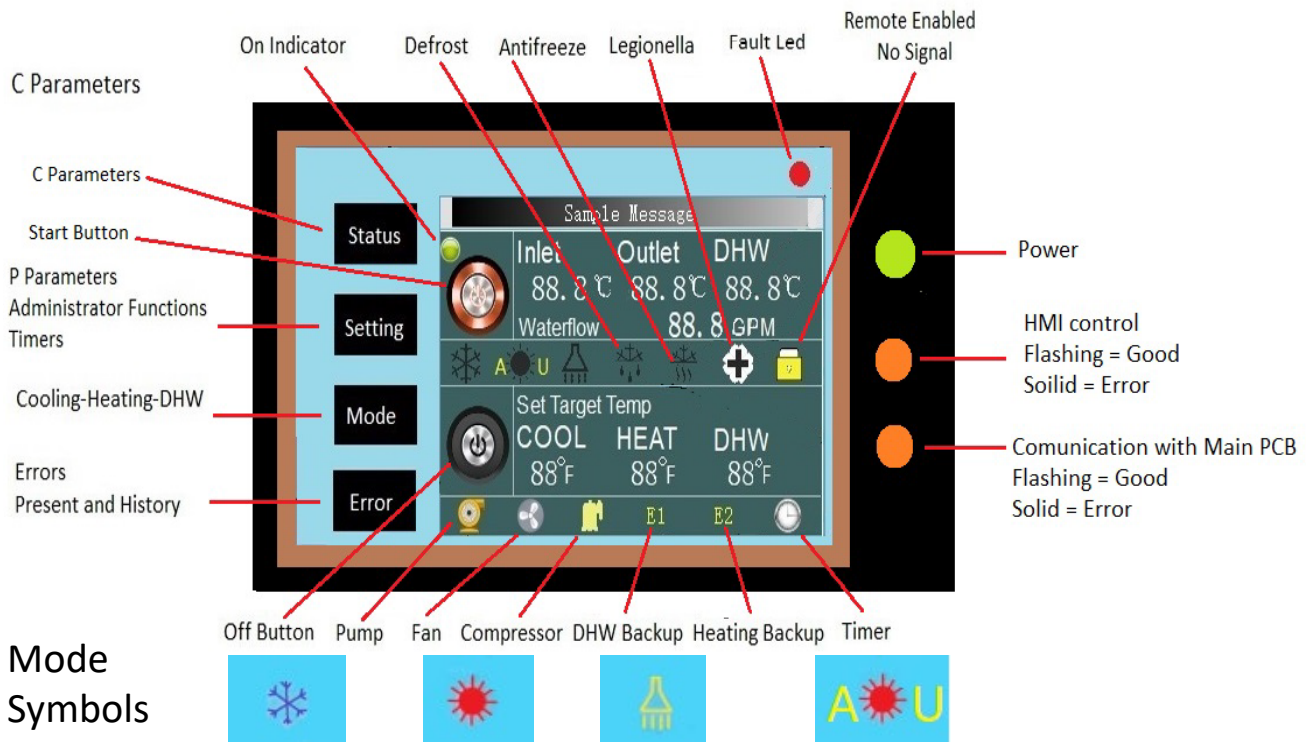

- Mode Symbols**
- Cooling      Heating      DHW      Heating with AU
- (1) **Taskbar:** shows the current running applications, and the time. Clicking on the different application boxes will switch to different applications.
  - (2) **Main window:** Displays the main window of the application that is currently running.
  - (3) **Application icon:** A desktop application that first highlights the icon when it is first clicked, and then clicked again to launch the application.

**Indoor Controller!**  
**This controller must be installed indoors.**



## cx50 Desktop

### Settings:

Chiltrix heat pump setting for space heating/cooling are always set for return temperature, with a steady-state leaving temperature +/- 9F

### Standard Settings:

Space cooling: 54F (note, this implies a leaving temperature of 44F)

Space heating: For Chiltrix supplies AHU/FCU 96F (Note this implies a 105F leaving temperature. Max recommended temp 111F (120F leaving temperature

DHW: Max 120F

### Keys Operation

### Status

Click "Status" at the home page to enter the status diagram, press the upper right hand corner where the 3 dashed lines are to get into the parameters page as shown on the next page.

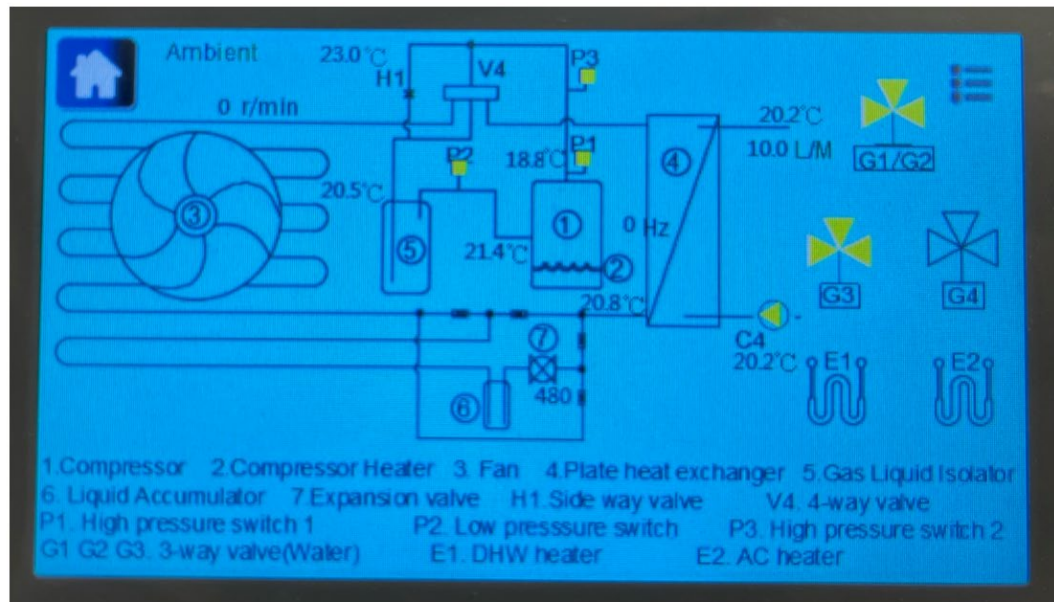
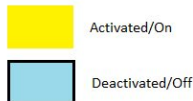

## CX50 Status Page Pre Software Version 108.1

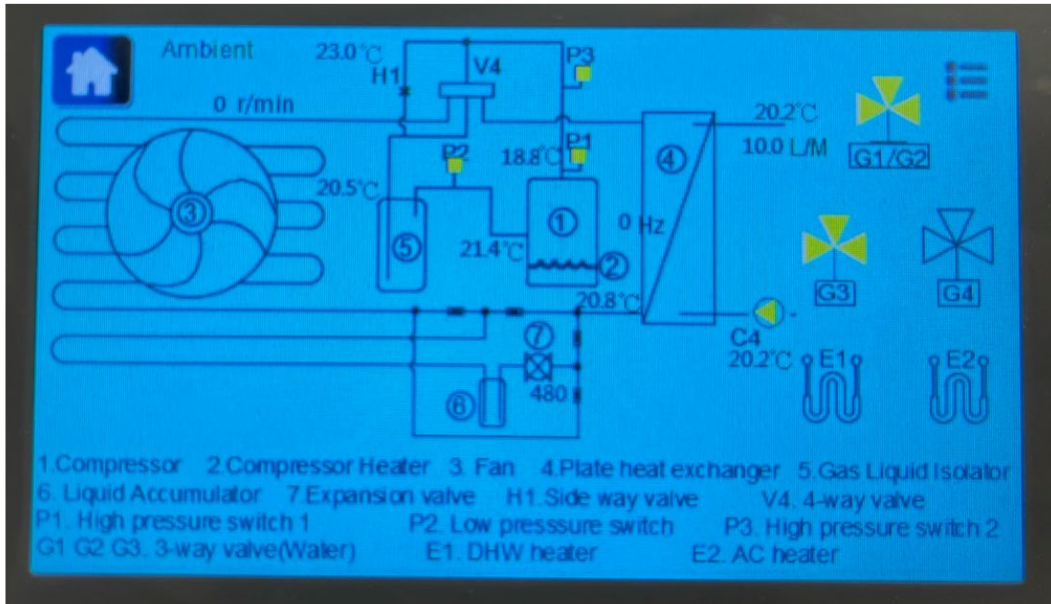
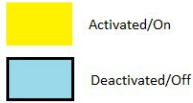

CX50 Status Page Pre Software Version 108.1 is shown above



Note the changes for different software's. It only changes how G1 and G2 are displayed, does not change any hardware or requirements.



## cx50 Desktop

### Keys Operation

#### Status

Click "Status" at the home page to enter the status, and then click the three lines at the right top to get into the "C parameters" below. Click the arrow ">" button to go to next page.

Item	Value
C00 Coil temp	0.0 °C
C01 Compressor discharge temp(AIN1)	0.0 °C
C02 Ambient temp	0.0 °C
C03 Suction temperature	0.0 °C
C04 Plate heat exchanger inlet temperature	0.0 °C

2022/11/04 17:26:29

1/15

Click **“Setting”** button, and you will enter the system setting page. Then you select the language, set time and Administrator settings.

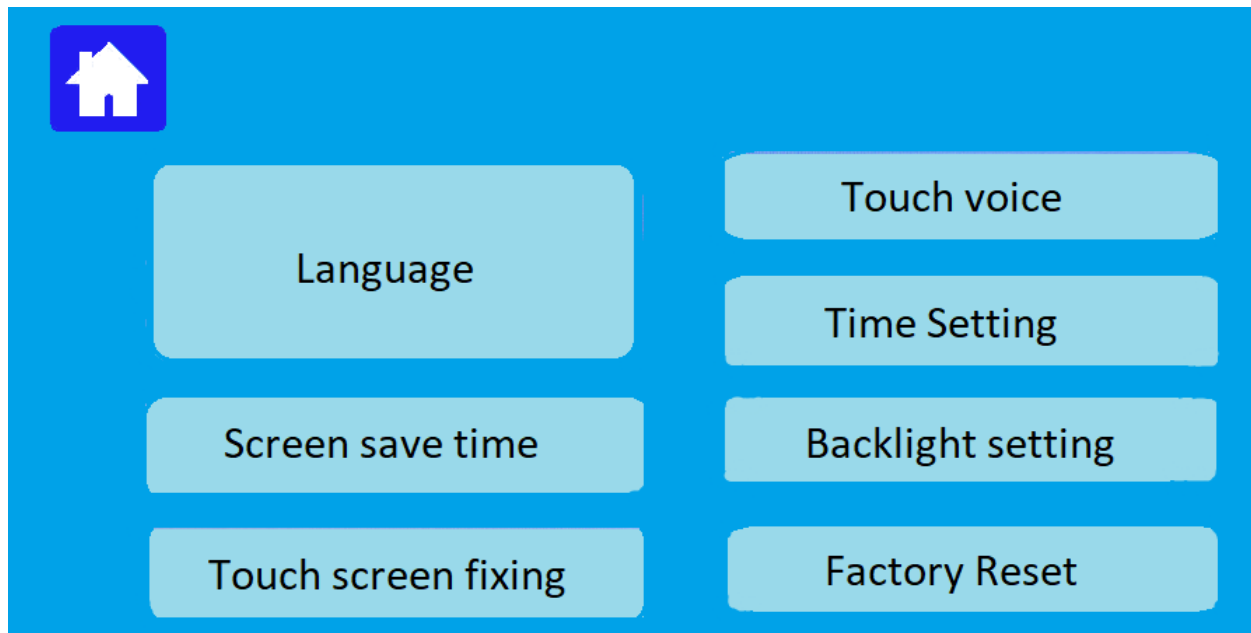
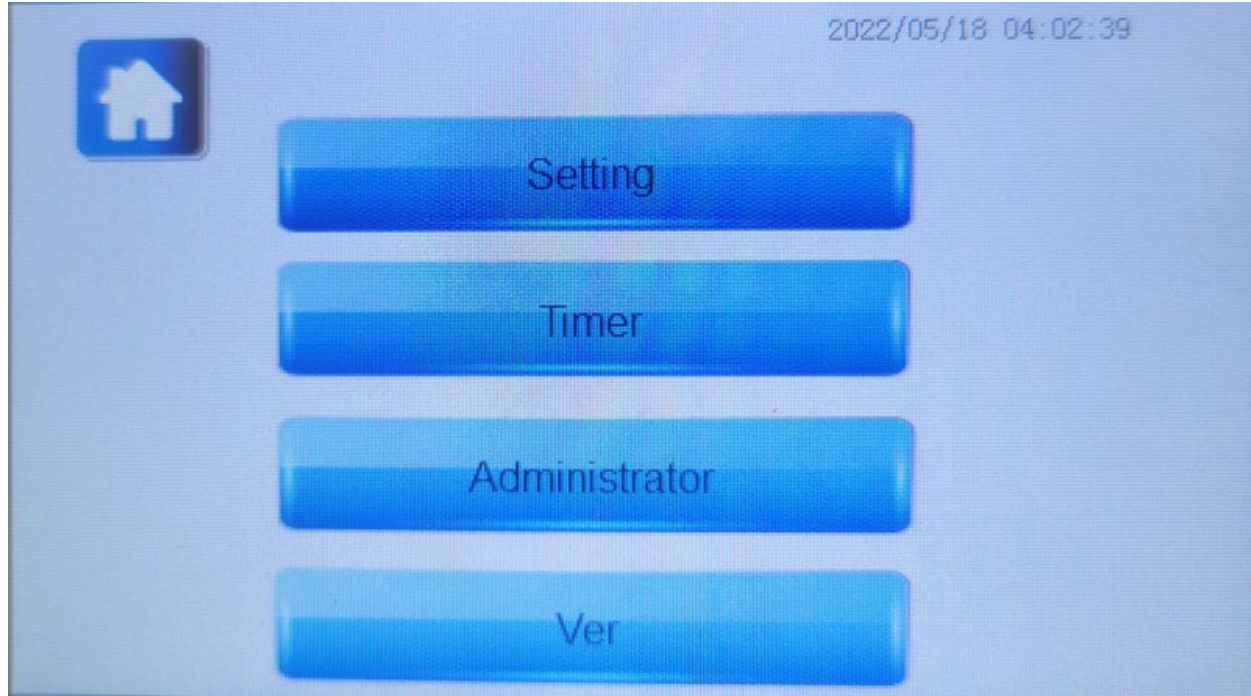

Settings Menu

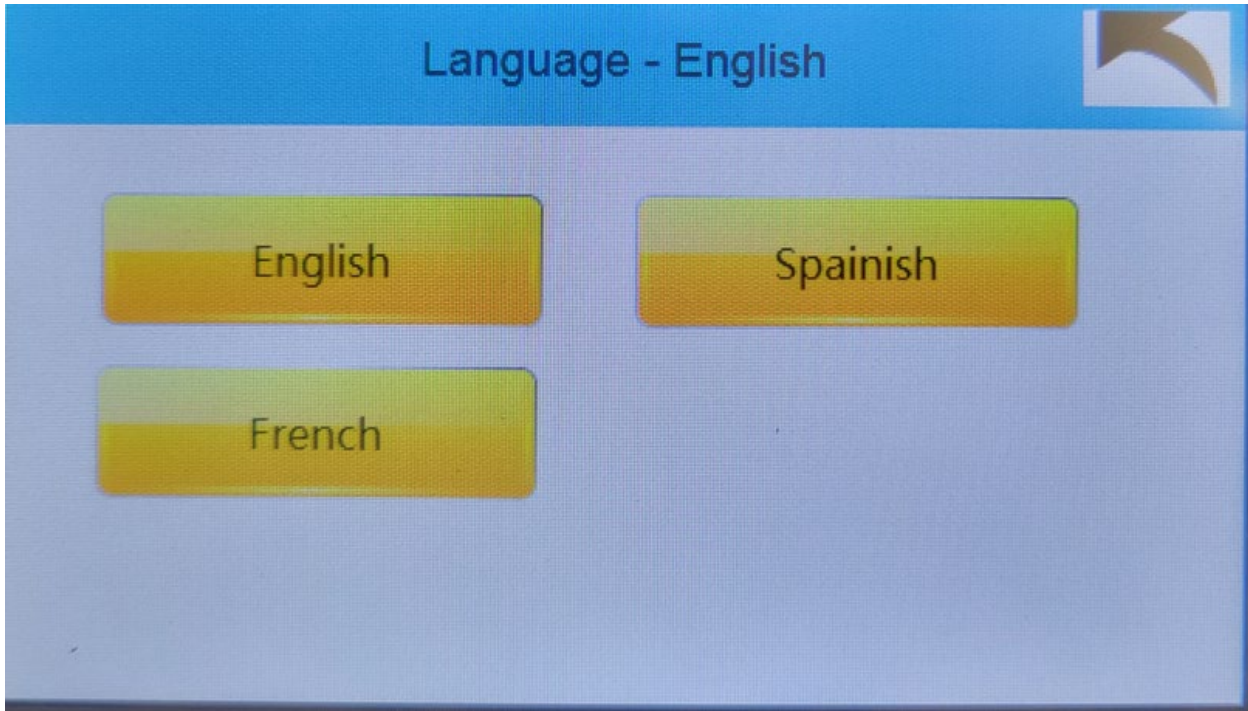

Language Screen

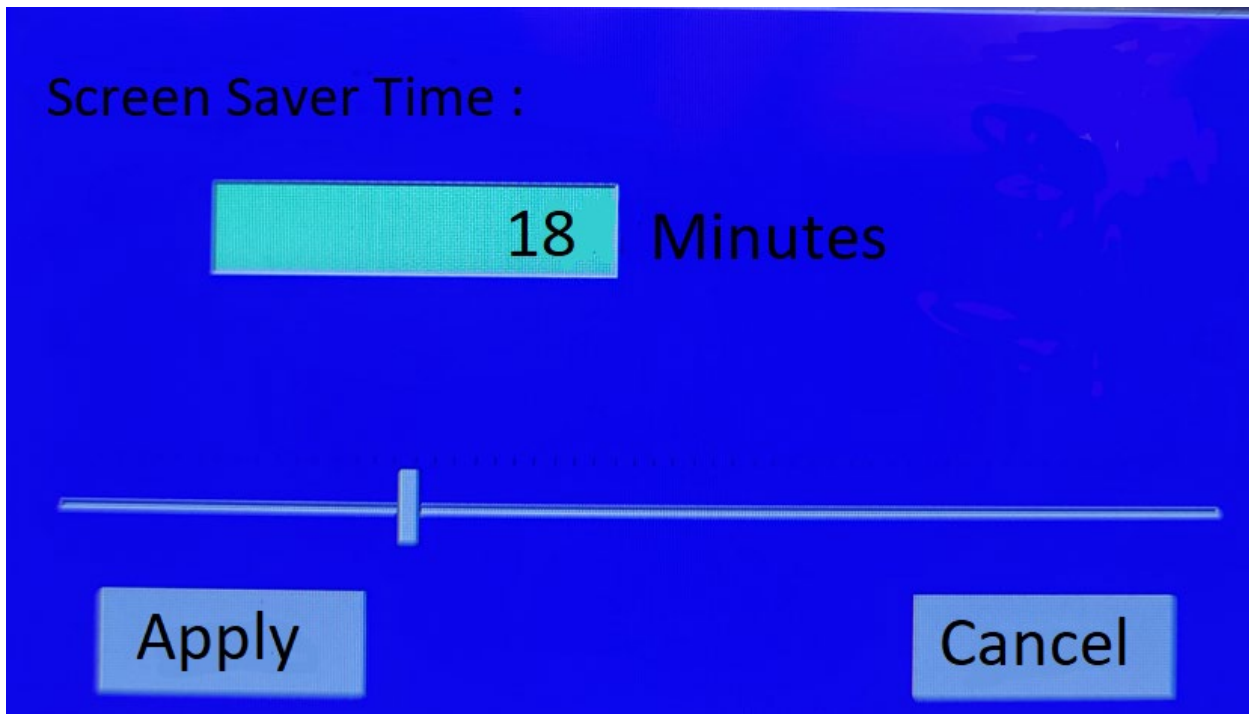

Screen Saver

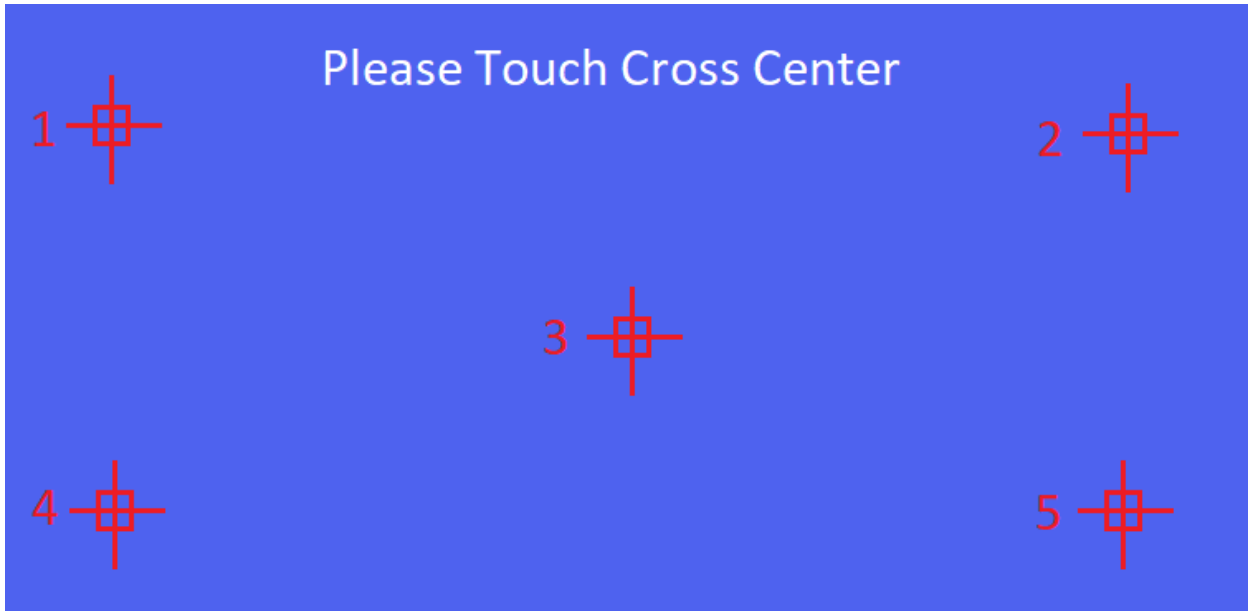

Touch Screen Fixing (Calibration)



Time Setting



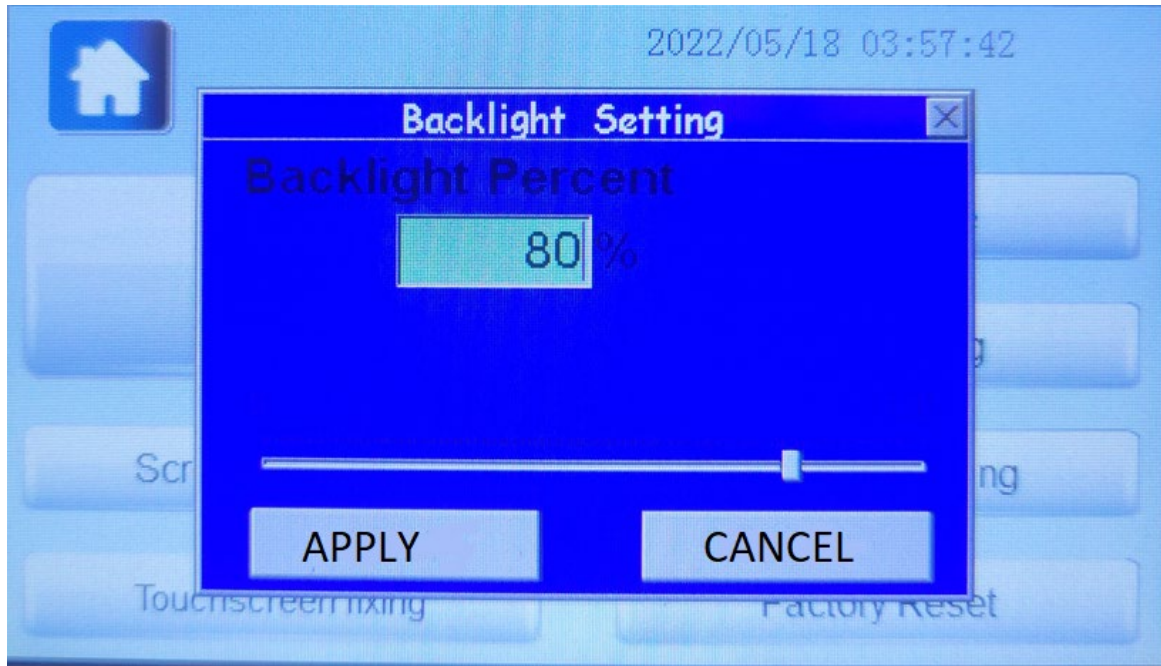

Back Light Setting

## Timer Function

Click “**Timer**” button, you can set the heat pump to turn on and off times, you can select different working modes for different time periods. There are total 4 periods, (8 points), in the timer setting.

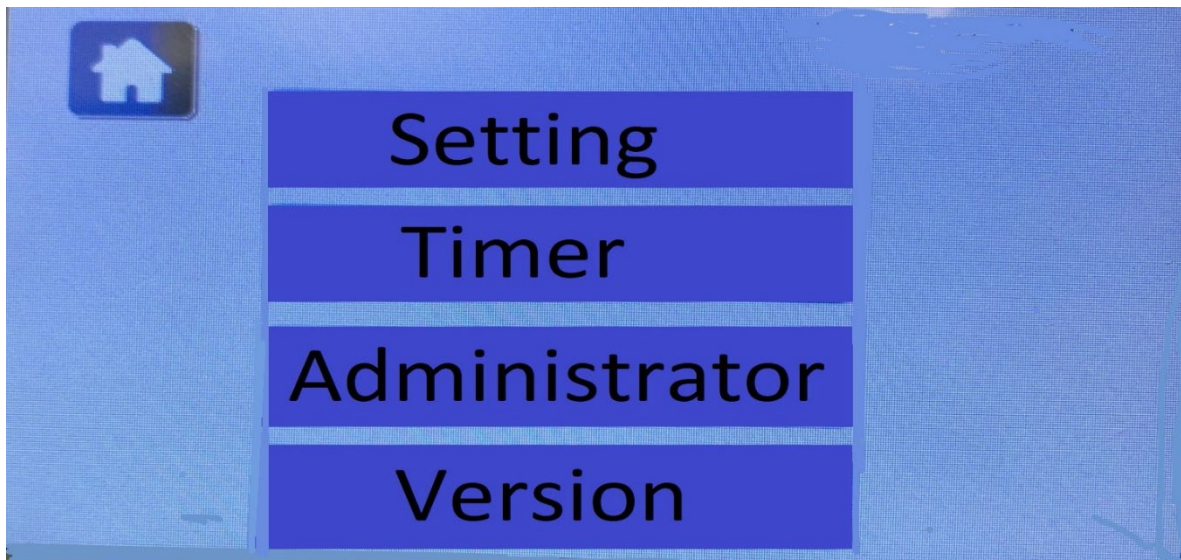

Press Timer to access the timer functions





Timers 1 and 2 set to Heating Mode with no times set

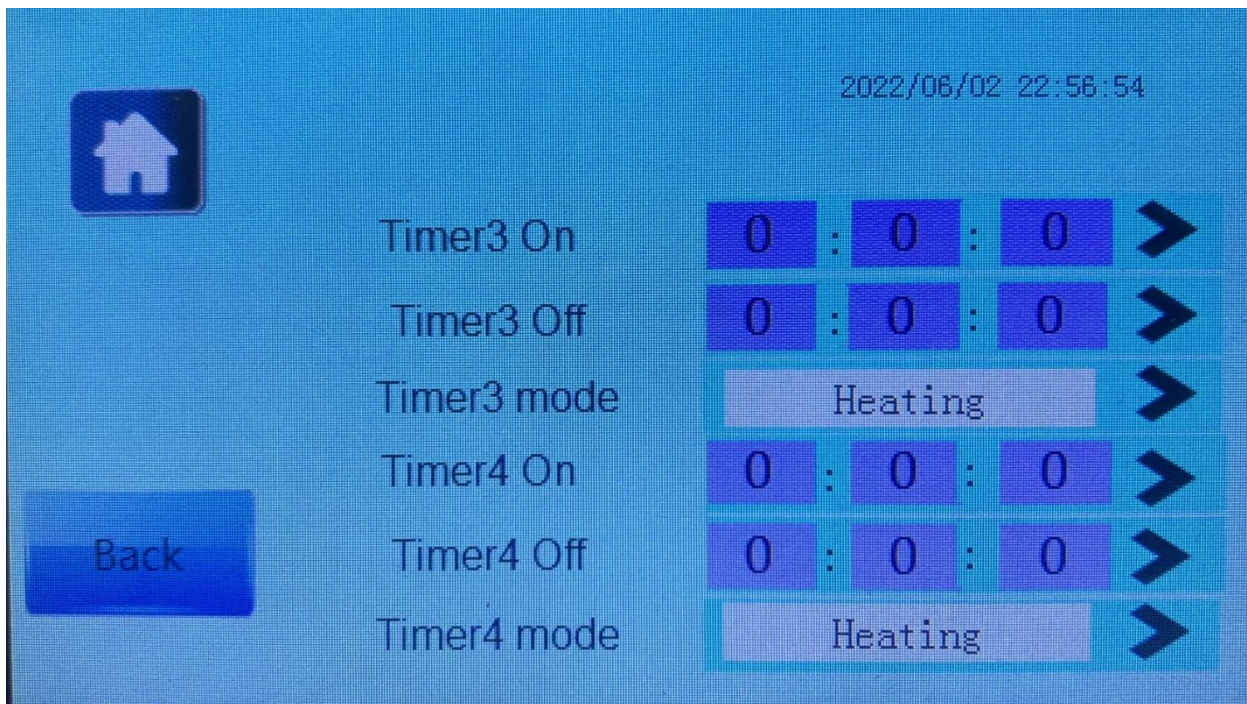

Timers 3 and 4 set to Heating mode with no times set



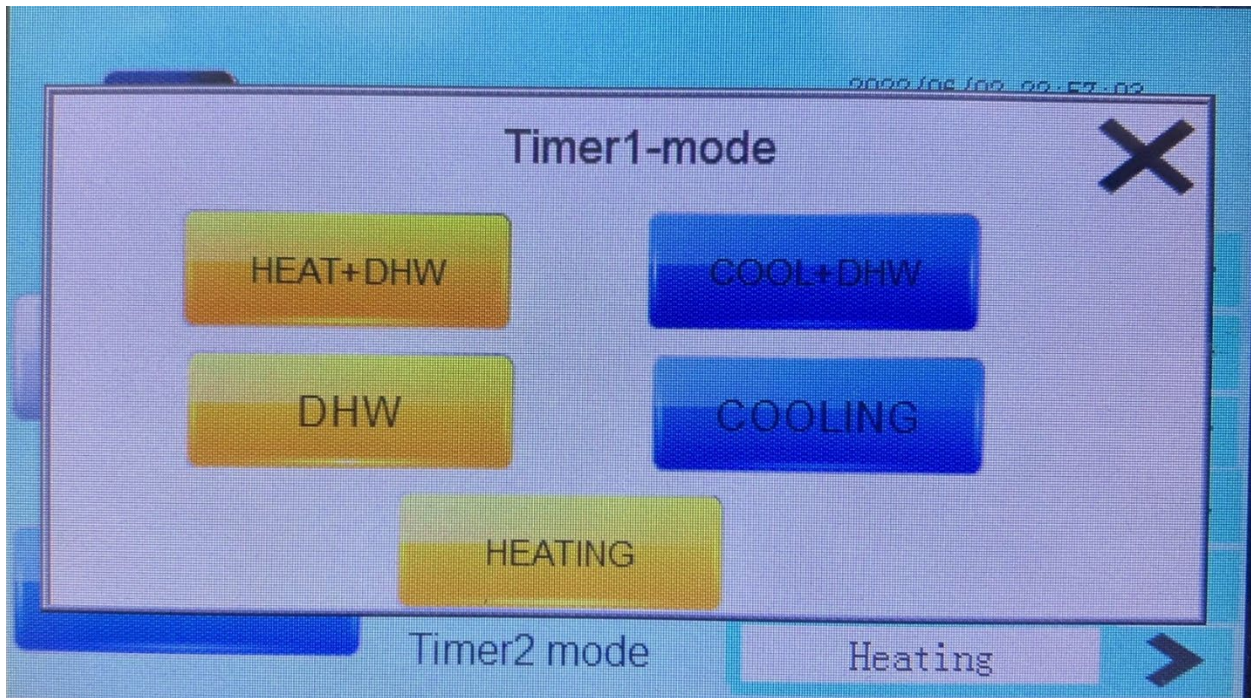

Setting the mode for timer 1, same menu for timers 1-4

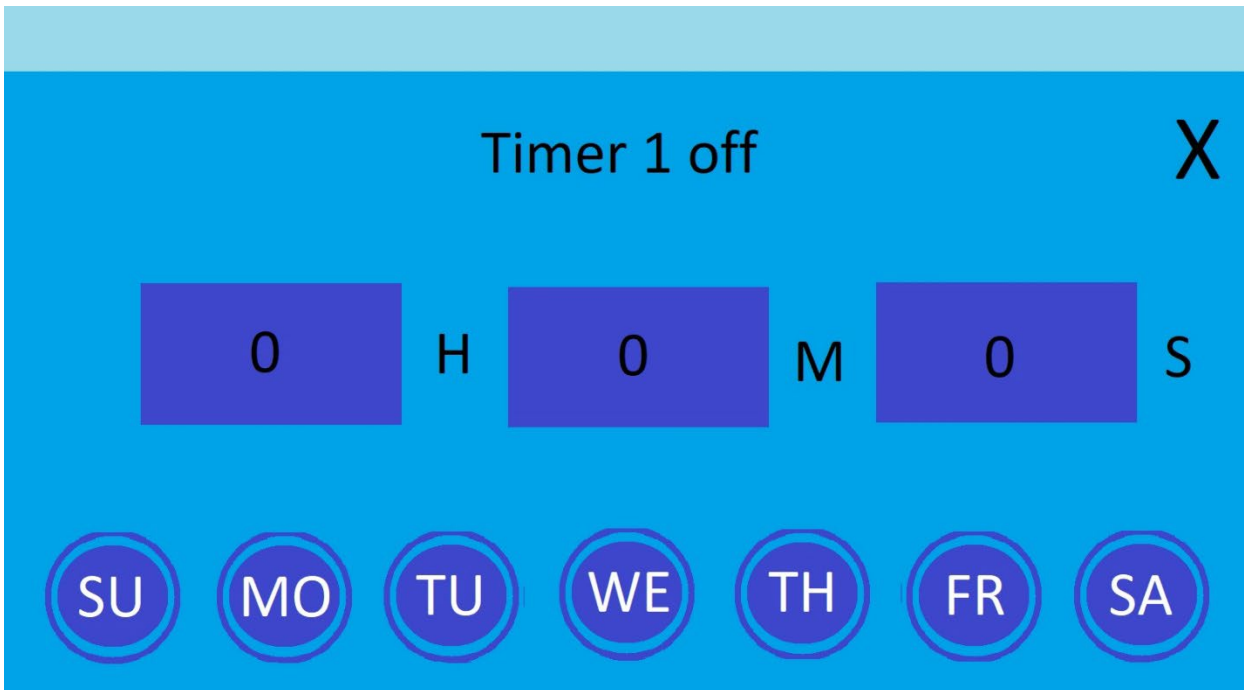

Timer 1 turned off, timers 1-4 use the same menu

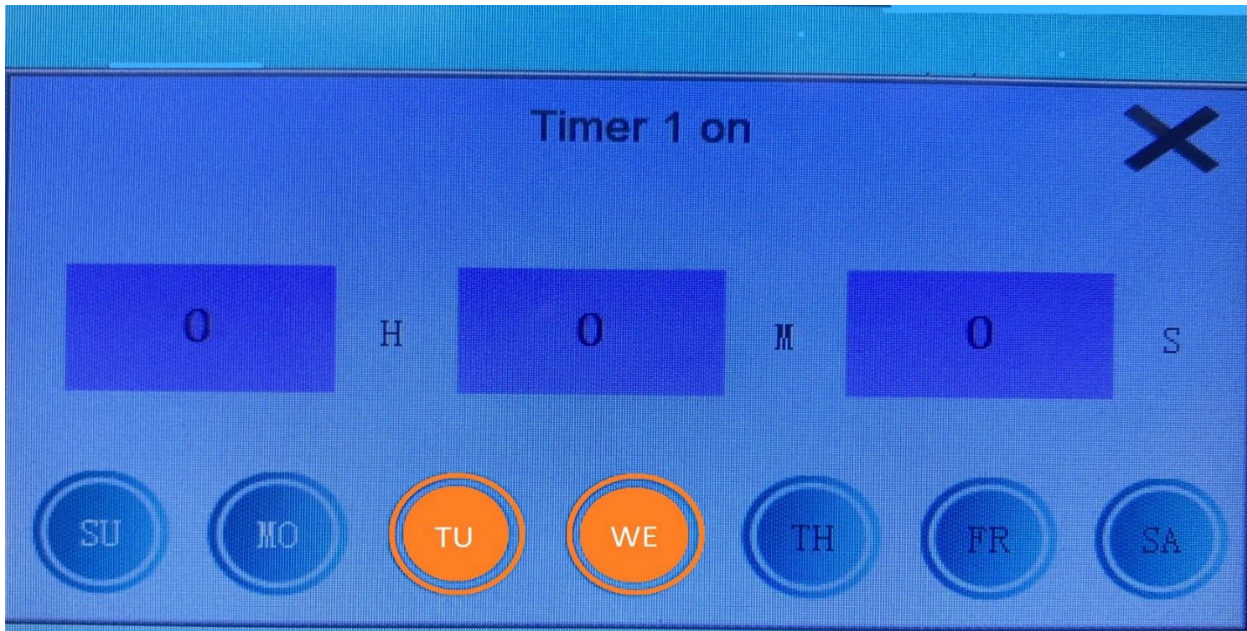

Timer 1 Start time and Days of the week selected (TU and WE), timers 1-4 use the same menu

### Administrator Functions

Click **“Administrator”** button, you need to enter the password **“2222”** to enter the **“P”** parameters setting page as shown below. Refer to **“P”** parameter section for parameter list. Example below.

Item	Value
P00 Power-down recovery function	0. w ➔
P01 Single/Three phase selection	0
P02 Power frequency	0
P03 Heat source selection	0:0 ➔
P04 Heating temperature control method	0

1/23

## Mode

Click “Mode” at homepage, you will enter mode selection page. To select the desired mode, press the corresponding button.

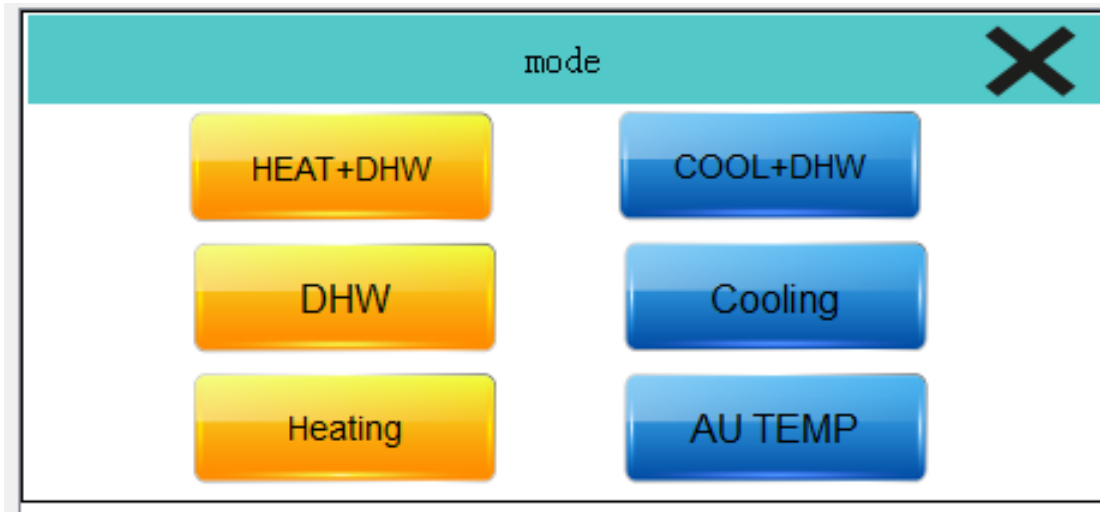

There are 5 standard modes available with DHW enabled, plus an AU Setting.

## **Auto Heating Target Curve Function**

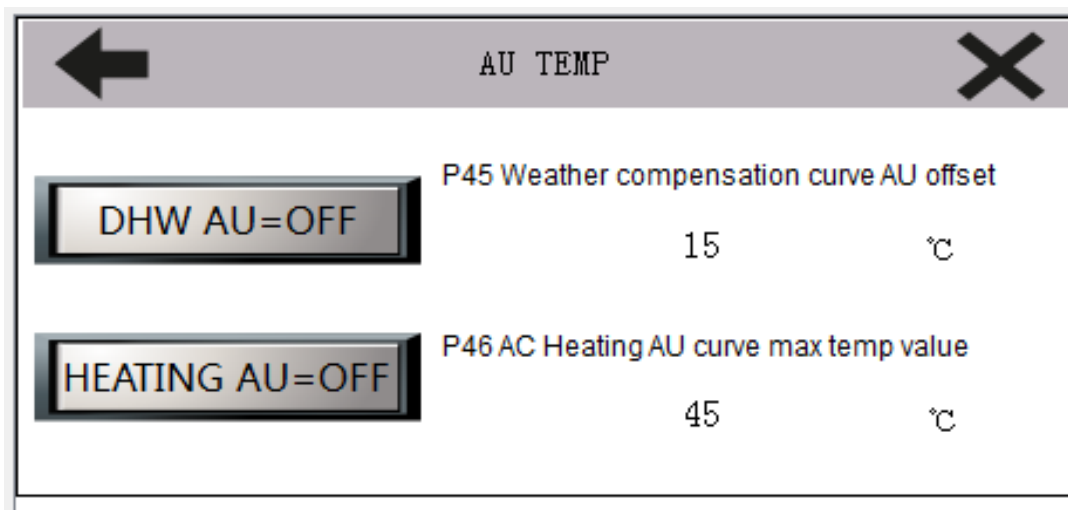

For HEATING AU configuration see <https://www.chiltrix.com/dynamic-heat-reset/>



## Error Log

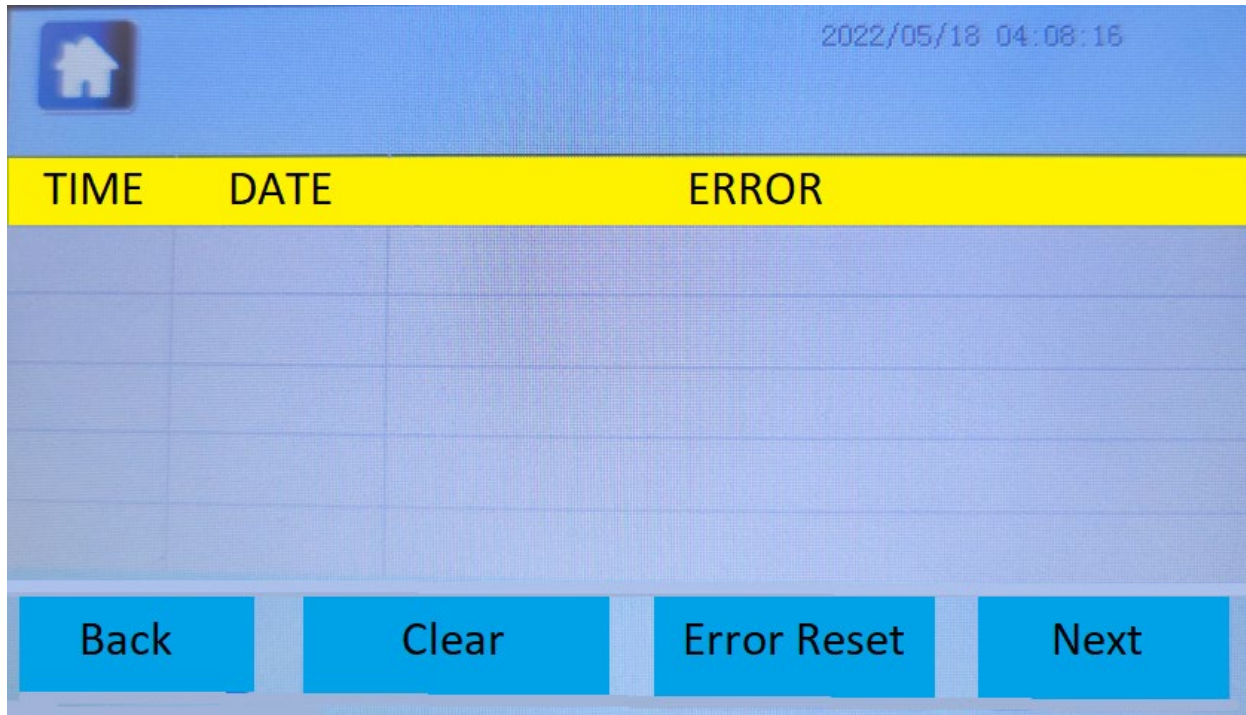

2022/05/18 04:08:16

TIME	DATE	ERROR

Back Clear Error Reset Next

Error Log above shown with no errors

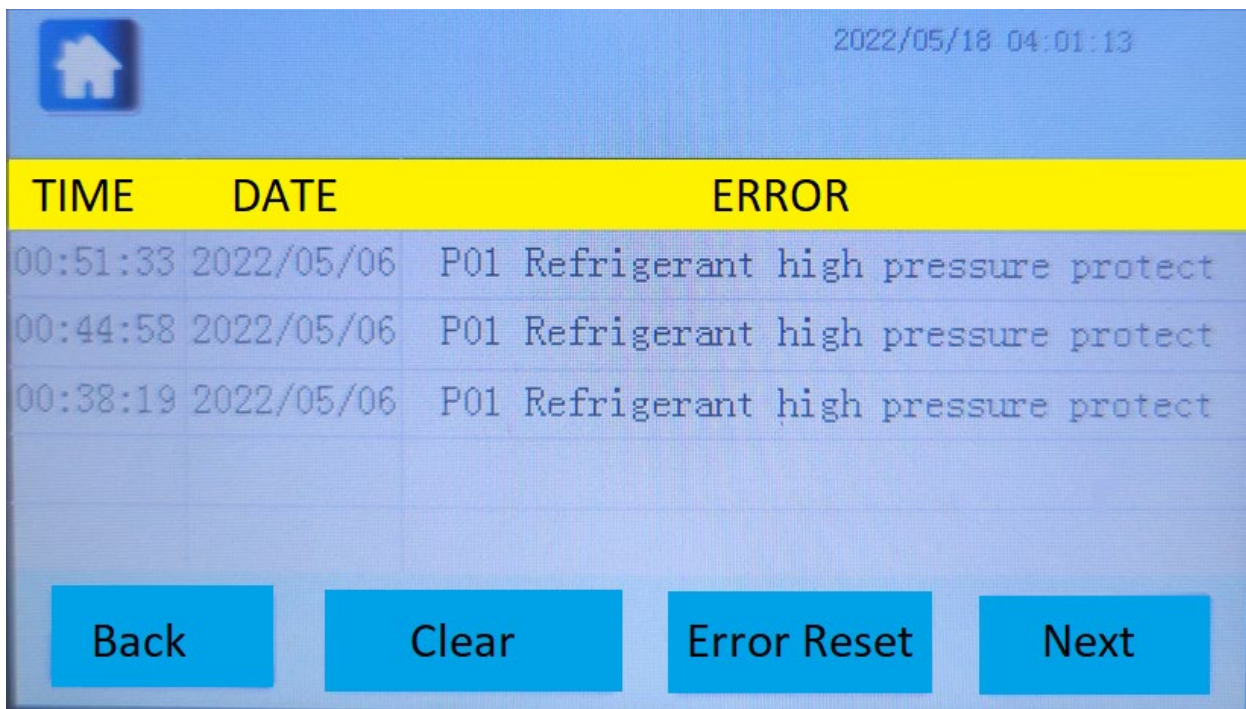

2022/05/18 04:01:13

TIME	DATE	ERROR
00:51:33	2022/05/06	P01 Refrigerant high pressure protect
00:44:58	2022/05/06	P01 Refrigerant high pressure protect
00:38:19	2022/05/06	P01 Refrigerant high pressure protect

Back Clear Error Reset Next

Error Log above shown with sample errors

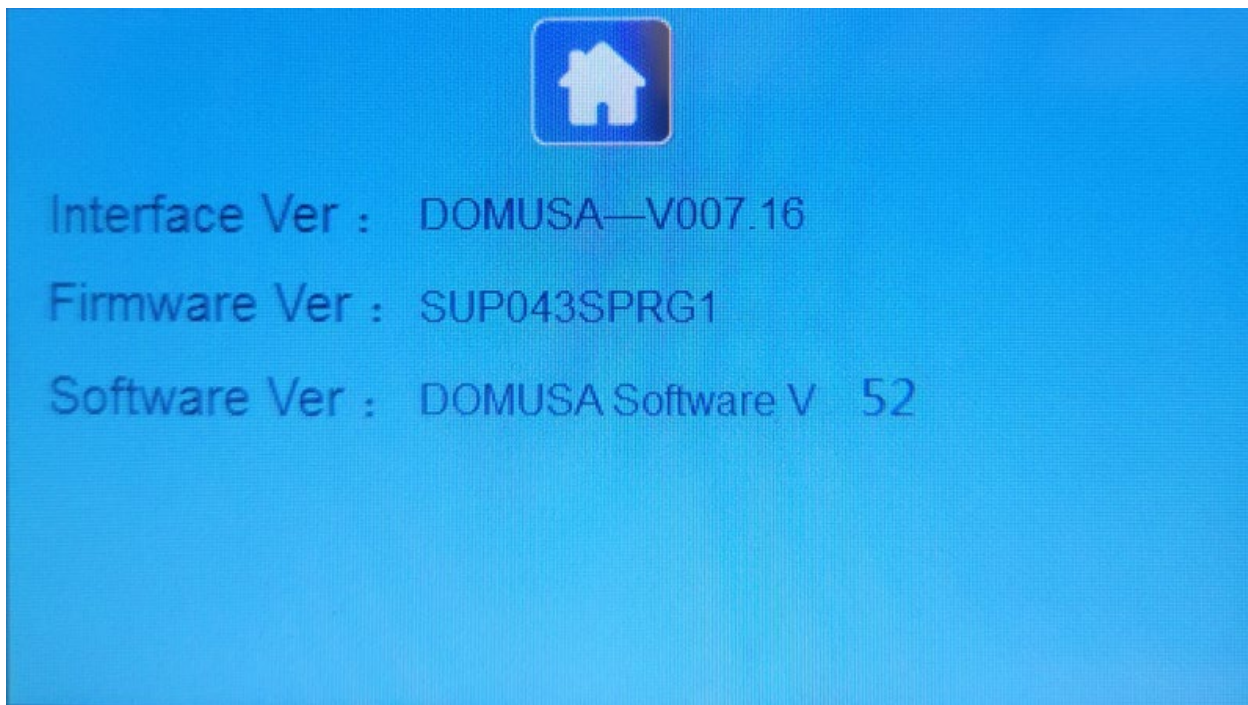

## Software Versions

The following pages contain the (LCD) C-Parameters, P-Parameters, and Error Codes.

To access the C-Parameters (read only), touch the “STATUS” button from the desktop.

To access the P-Parameters touch the “SETTINGS” button from the desk top.

To access the Error Codes touch the “ERROR” button from the desktop.

### **Suggested/supported Settings:**

**Space cooling: 53F (note, this implies a leaving temperature of 44F)**

**Space heating: For Chiltrix supplied AHU/FCU 96F (Note this implies a 105F leaving temperature. Max recommended temp 111F (120F leaving temperature))**

**DHW: Max 120F**

## P- Parameters

P00	Power-down recovery function	0 : off ; 1 : on	1
P01	Single / three phase selection	0 : Single-phase power supply Three-0 phase power supply	0
P02	Power frequency	5 : 50HZ ; 6 : 60HZ	1
P03	Heat source selection	0 : Geo ; 1 : Air source	1
P04	Heating temperature control method	0 : Method 1 : 1 : Method 2	0
P05	Defrost method selection	0 : Method 1 : 1 : Method 2	0
P06	FREECOOLING validation	0 : valid ; 1 : invalid	1
P07	Frequency control method	0 : Method 1 ; 1 : Method 2	0
P08	DHW validation	0 : valid ; 1 : invalid	1
P09	Air conditioning and heating validation	0 : valid ; 1 : invalid	0
P10	Air conditioning and Cooling validation	0 : valid ; 1 : invalid	0
P11	DHW hot water temp hysteresis	2~15°C, minus hysteresis	2°C
P12	AC temp hysteresis	2~15°C, minus hysteresis	2°C
P15*	Comp Disabled for DHW below this ambient Temp (Note: only for software ver 108.1 and greater)	"-30-60°C"	2°C
P23*	C4 PWM Pump Control Method (Note: only for software ver 108.1 and greater)	0: Normal 1: SS Pump	0
P24	P24 Start Au Outdoor Temp	-10~20	5
P25	Start Au Min_Temp	20~45	20
P26	Ramp Au	1~5	4
P27	Max percentage speed of compressor	55~100%	100%
P30	fan motor Category	0 : AC Fan ; 1 : EC Fan1 2:EC Fan2	1
P31	Maximum speed of the fan	1-10 (10=100%)	100
P32	Heating fan speed control temperature difference	2~15°C	4
P33	Cooling Fan speed control Temperature difference	5~18°C	6
P34	Defrost method	0 : Method 1 ; 1 : Method 2	0
P35	defrost starting temp	-5~5°C	-1°C
P36	defrost interval time multiple rate	0 : Not defrost ; 1 ; 2 ; 3 ; 4 : ( intervalX4)	1
P37	The first defrost interval	15~99minute (1st interval after 50 repower on)	50
P38	defrost exist temp	10~35°C	30°C
P39	Start Defrost air-coil difference	0-40°C	8
P40	Electric heater start delay minute	5-30min	10
P41	SSR Ramp Up rate	1-20min	5
P42*	Automatic heating temperature (Note: software ver 108.1 and lower default to 0)	0-18°C	15



## P-Parameters

P43*	Automatic cooling temperature (Note: software ver 108.1 and lower default to 0)	0-28°C	23
P45	Allowed defrost coil temperature	-20~5°C	-4
P47	hot water frequency limitation	4~10= max frequency 40~100%	10
P48	AC heating AU mode highest temp	30~50°C	45°C
P49	AC Heating AU mode offset temperature	-10~10°C	0°C
P50	solenoid valve function parameters	0 : G3 is seasonal valve ; 1 : G3is solar valve ;	0
P51	C4 Water pump type selection	0 : AC Water pump ; 1 : EC Water pump	1
P52	water pump working mode	0(Not stop)、 1.stop after reach target temp、 2 (start 1 minute after each stop 15 minutes)	0
P53	EC Water pump C4 Minimum speed	20-80%	4
P54	C5 Water pump type selection	0 : AC Water pump ; 1:EC water pump	0
P55	DHW e-heater activated ambient temp	"-20~50°C"	0°C
P56*	Electric heating function (Note: only software ver 108.1 and greater allow for setting "2")	0 : Electric heater ; 1 : second heat source; 2: No Backup heating	0
P57	AC e-heater activated ambient temp	-20~20°C	0°C
P58*	Ambient temp to disable comp (Note: ONLY software ver 108.1 and greater will allow you to do this.)	-30~15°C	-15°C
P59	AC anti-freezing temperature	-15~5°C	3°C
P60	Virus killing interval days	7~99 day	7day
P61	Start virus killing time	1~24 hour	1
P62	Virus killing holding time	5~360 Min	10
P63	Target temperature of virus killing	55~80°C	65°C
P64	AC water flow switch type selection	0 : Normal Water flow switch ; 1 : 1 Water flow volume meter sensor 2:DN50 water flow sensor 3: New flow sensor SEN-HZG1WA	1
P65	AC minimum water flow	3-80L/m	cx35: 8 cx50: 14
P66	Water source Water flow switch type selection	0 : Normal Water flow switch ; 1 : 0 Water flow volume meter switch	0
P67	The lowest water flow of water source	3-80L/m	20
P68	air source heat pump FREECOOLING function start ambient temp	-16~20°C	5°C
P69	Air source FREECOOLING function additional Temperature difference to start full free cooling.(compressor stop)	3~15°C	5°C
P71	Cooling Maximum set temperature	15~35°C	25°C
P72	Heating maximum set temperature	25~55°C	55°C
P73	DHW The highest set temperature	25~60°C	60°C
P74	Debugging fixed operating frequency	10~100 HZ	50HZ
P75	run setting frequency	0 : Manual frequency ; 1 : Auto frequency	1
P76	EEV manually open degree (heating)	70~480	200

## P-Parameters

P77	EEV manually open degree (cooling)	70~480	250
P78	EEV control mode	0—No ; 1—tabel list ; 2—manually ; 3—automatically	
P79	target overheat degree (heating)	-5~10°C	-1°C
P80	target overheat degree (cooling)	-5~10°C	2°C
P81	night mode validation	0 (not start) 、 1 (start)	0
P82	night mode starting point	0-23 (for relative time)	22
P83	night mode ending point	0-23 (for relative time)	6
P88	Model selection	0~255	4
P94	Whether to use high and low pressure transmitter	0 Disabled; 1 Used	0
P95	temperature difference to control C4 water pump speed	2~8	5
P96	EEV min open degree		70
P97	Forced sterilization	0,normal;1,forced;(Automatic recovery of 0 after execution)	0
P98	System parameter recovery	0 normal; 1 Recovery (automatically reset 0 after one execution)	0
P99	Compressor manufacturer 2		101
P100	Virus killing function validation	P100=0 Invaidd; 1 valid	0
P101	EEV Max manual open	300-500 default:430	480
P102	Defrosting EEV manual open		350
P103	AC electric heater Power W	0-99999w default:5500	5500
P104*	C or F degree (Note: only software version 108.1 and greater default to F)	0:C degree; 1:F degree	1: F
P105	Heat recovery function validation	0:Invalid; 1:valid	
P106	AC heater rated voltage	0-500V	220
P107	AC heater transfer coefficient	100-600WF	500
P108	AC Voltage compensation		0
P109	Cooling Inlet Target temp range	P109=0:10~25C. P109=1:5~25C(Must use glycol no frozen at -10C).	0
P110	AC heating minimum frequency	30~50hz	30hz
P111	DIN6 DIN7 switch		Disable
P112*	AU-Mode enable bit (Note: only software ver 108.1 and greater have two buttons for cooling and heating)	Cooling Disabled:Heating Disabled	Both Disabled

## C Parameters

C00	Coil temp	-30~97°C
C01	compressor discharge temp(ain1)	-30~128°C
C02	ambient temp	-30~97°C
C03	Suction temperature	-30~97°C
C04	Plate heat exchanger inlet temperature	-30~97°C
C05	AC outlet water temp	-30~97°C
C06	Solar temperature	-30~97°C
C09	Compressor current value(Tested by main IPM)	0.00~30.00A(show P4 if C09>max current)
C13	Usage side water flow volume	0~100L/m
C14	P03 Status	1 Air source; 0 Ground Source
C15	P04 Status	AC heating temp control method
C16	P05 Status	Defrost method
C17	P06 Status	Free cooling:0 valid, 1,invalid
C18	P07 Status	Frequency method
C19	P08 Status	0 DHW valid; 1 DHW invalid
C20	P09 Status	AC heating valid; 0: valid 1: invalid
C21	P10 Status	0 Cooling valid; ; 1 Cooling invalid
C22	high pressure switch status	1 (on) ; 0 (off)
C23	low pressure switch status	1 (on) ; 0 (off)
C24	second high pressure switch status	1 (on) ; 0 (off)
C25	inner water flow switch	1 (on) ; 0 (off)
C27	Compressor Frequency	Show actual frequency
C28	overheat switch status	1 (on) ; 0 (off)
C29	outdoor fan motor	1 (on) ; 0 (off)
C30	electrical valve 1	1: run; 0: stop
C31	electrical valve 2	1: run; 0: sttop
C32	electrical valve 3	1: run; 0: stop
C33	electrical valve 4	1: run; 0: stop
C34	C4water pump	1: run; 0: stop
C35	C5water pump	1: run; 0: stop
C36	C6water pump	1: run; 0: stop
C37	The accumulative days after last virus killing	0-99 (from the last complete sterilization to the present cumulative number of days)
C38	Compressor model Encode ( By Main board dialing SW10-15 )	
C39	Expansion valve 1 opening degree	0~500
C40	Expansion valve 2 opening degree	0~500
C41	inner pipe temp display	-30~97°C

## C Parameters

C42	Heating Method 2 target temperature	-30~97°C
C43	Running returning lubrication oil function.	1: On; 0: Off
C44	fan type	0: AC fan; 1: EC fan
C45	EC fan motor 1 speed	0~3000
C46	EC fan motor 2 speed	0~3000
C47	water pump types	0: AC WATER PUMP; 1 EC WATER PUMP
C48	water pump1 speed	1~10 (10 means 100%)
C49	water pump2 speed	1~10 (10 means 100%)
C50	Inductor AC Current value	0~50A
C51	Driver working status value	Hexadecimal values
C52	Compressor shut down Code	Hexadecimal values
C53	Driver allowed highest frequency	30-120Hz
C54	Reduce frequency temperature setting	55~200°C
C55	input AC Voltage value	0~550V
C56	input AC current value	0~50A (IPM Check, if C56>ipm MAXcurrent, show F5)
C57	Compressor phase current value(Compressor U,V,W wire DC current)	0~50A (IPM Check, show F4 on error)
C58	Bus line voltage	0~750V
C59	Fan shutdown Code	Hexadecimal values
C60	IPM temp	55~200°C
C61	<b>Compressor total running time</b>	0~65000 hour
C62	<b>E-heater Compensation power</b>	0~4294967295W
C63	din6 AC heating mode switch	0=OPEN; 1=CLOSE.
C64	<b>din7 AC cooling mode switch</b>	0=OPEN; 1=CLOSE.



1	Compressor discharge high temp protection	E1
2	Outdoor air temp sensor error	E2
3	Outer coil pipe temp sensor error	E3
4	Pipe returned gas sensor error	E4
5	indoor refrigerant pipe temp sensor error	E5
6	Coil high temp protection	E6
7	solar water temp sensor error	E7
8	AC inlet water temp sensor error	E8
9	AC outlet water temp sensor error	E9
10	DHW temp sensor error	E10
11	Indoor ambient sensor error	E11
12	water source inlet water temp sensor error	E12
13	water source outlet temp sensor	E13
14	system anti freeze twice	E14
15	DHW anti freeze twice	E15
16	discharge Probe error	E16
17	high pressure protection	P1
18	low pressure protection	P2
19	compressor overheat protection	P3
20	over current protection	P4
21	indoor unit water flow error	P5
22	outdoor water flow error	P6
23	miss phase	P7
24	wrong phase	P8
25	communication error	P9
26	water source anti freeze	P10
27	water source water flow not enough	P11

# Error Codes

28	<b>voltage protection</b>	<b>F1</b>
29	IPM Fault	F2
30	Compressor Drive Fault	F3
31	Compressor over current protection 1(DC current on U,V,W wire of compressor pins, checked by IPM)	F4
32		
33	IPM Overheat	F6
34	PFC Fault	F7
35	DC bus overvoltage	F8
36	DC bus undervoltage	F9
37	AC input over or under voltage	F10
38	<b>AC input current protection(AC current of compressor+fan motor+water pump, checked by IPM)</b>	<b>F11</b>
39	Temperature sensor Fault	F12
40	DSP and mainboard communication Fault	F13
41	Control board and inverter communication fault	P13
42	Inlet and Outlet water temp difference is too big	P14
43	AC system antifreeze twice	E17
44		
45		
46	Control panel parameters are not initialized	P12
47		
48	EC fan 1 Fault	F14
49	EC fsn 2 Fault	F15
50	Heat recovery warning	P12



## Dynamic Outdoor Reset Control (AU of HEAT)

The Chiltrix heat pump unit is equipped with an automatic outdoor reset function that can be accessed via the onboard controller.

### Advantages & Misconceptions of Using Outdoor Reset

Most people in the radiant heating industry will tell you that outdoor reset is used to get more BTU delivery from the radiant system on a day when the radiant system can't deliver enough BTUs to keep up with the load, and they use outdoor reset to crank up the radiant heat operating temperature to 120F, or higher. While that's true, it's also true that the best designed air to water radiant systems will be able to deliver what's needed at a fairly low temperature even with severe outdoor design conditions.

So if you can't get enough radiant capacity into the floor, then if possible, add some to the walls or ceiling. Note that radiant heat works just as well from the ceiling or walls as it does from a floor. And in some cases, it works better from the ceiling.

### Why does keeping the operating temperature low matter so much?

With a fossil fuel burning boiler, it doesn't matter. Gas, propane, and oil efficiency does not vary with outdoor temperature. But that's not the case with a heat pump.

Here's why:

$$W = \frac{Q_1}{COP_p} = \frac{Q_1(T_1 - T_2)}{\eta_{mech} T_1}$$

For a real-world example, at 0F outdoor temperature, an air to water heat pump such as the cx50 will have >20% higher capacity when used with an operating temperature of 95F compared to operating at 122F. And COP at 95F will be >30% higher at 95F than at 122F.

### So why use outdoor reset?

You can use reset when it is simply not possible to design the indoor side of a system to handle the peak BTU load using a low operating temperature. **But the best use of reset is as a strategy for extra energy savings**, by designing the indoor side of the system to handle the peak load at the lowest possible operating temperature, **and then letting the system automatically reset to an even lower and even more efficient temperature at times when weather is milder!**

## How to Use Chiltrix Dynamic Outdoor Reset Control Use With or Without V18-B Backup Heat

Use the free Excel curve development worksheet tool to create the proper curve and discover correct parameter settings for P48 and P49. The tool is located at <https://www.chiltrix.com/dynamic-heat-reset> Make sure to select the correct tool for your model.

Set parameter P48 and P49 in cx50 controller according to the values used in your curve worksheet.

There is an "AU TEMP" icon inside the mode section of the main screen of the controller. If you press on it then you will enter the AU TEMP mode screen. You will need to enable "HEATING AU" to ON. With AU Heating on, it will be displayed as an orange/red color.

From there you can adjust the "weather compensation curve AU offset" and the "AC Heating AU curve max temp value". The "AU" will also be illuminated on the main screen around the heat mode.

Enable AU of heat mode as shown below.

### DO NOT USE DHW AU

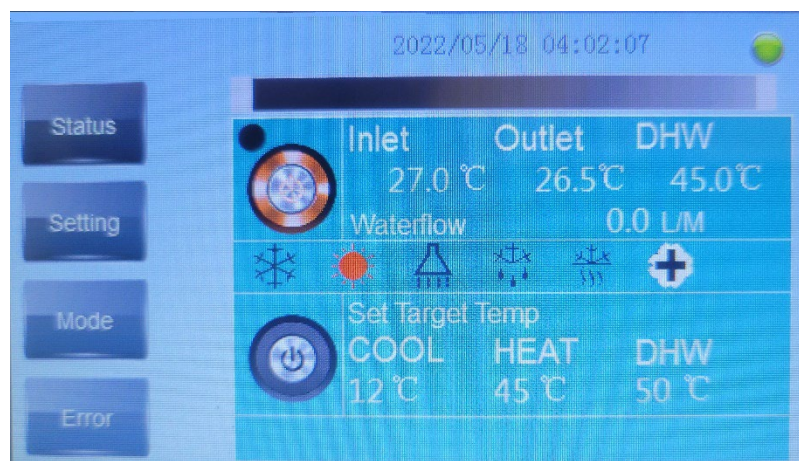
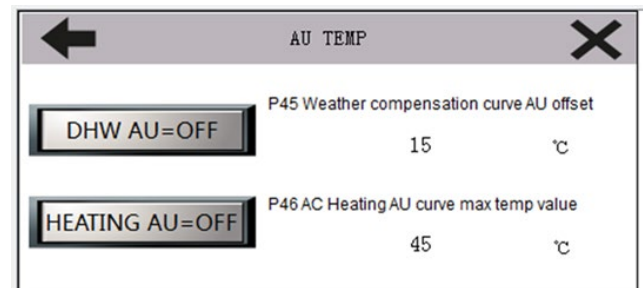
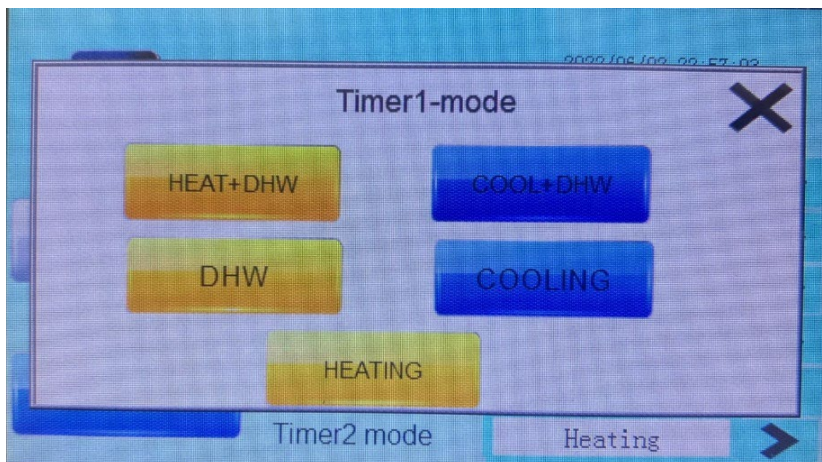

## How to Use Automatic Switch-Over

This is now an on-board function and does not require a separate add-on controller to operate. This function allows the cx50 to automatically select its mode, either heating, cooling, or standby (off), according to outdoor temperature. This can be particularly useful for example, if a single cx50 is shared by two different tenants, allowing the property manager to (automatically) select the mode according to the actual outdoor weather conditions.

There is a minimum of 4C (7.2F) deadband built-in so as to limit daily switching. A suggested setting would be to run in heating mode when outdoor temperature is 60F or below, use cooling when outdoor temperature is 69F or above, and between 60-69 the system will be in standby (off) mode.

If your cx50 is used with a Psychrologix controller, please make sure the Psychrologix auto-switchover function is disabled and only use the on-board automatic switchover function. Or, vice-versa. Only one method of external control can be used on the same system. Likewise, this function cannot be used on either controller if you are using C-H-COM remote relay mode control.

To use this function, follow these 6 steps:

1. Make sure that C-H-Com are NOT being used. The jumpers that are supplied should remain in place as shown on page 28
2. You must enable P112.
3. Note that P42 and P43 temperatures are in C not F.
4. The settings P42 and P43 must be at least 4C different between each other.
5. Result: If outdoor air drops below P42 the system will switch to heating.
6. If outdoor temperature rises above P43 the system will switch to cooling.
7. P112 must be enabled on both heating and cooling to operate auto switch over.

## Commissioning “To Be Performed In Heating Mode Only” An as-built design will need to be provided to Chiltrix by email before the commissioning call.

**For Commissioning please arrange a commissioning call with Chiltrix Support Dept. +1 757-410-8640 Ext. 112**

### **PLEASE MAKE SURE TO CALL CHILTRIX BEFORE COMMISSIONING**

#### Preparation

After finishing the installation tasks, please check the items below:

1. Check the Wired Controller P Parameters for the most updated settings.
2. Check that the power cable is securely connected and the screws are tight.
3. Is the display lit on the wired controller after the power is applied?
4. Verify that all the shut off valves and manual valves are open. Insulate all water supply and return pipes.
5. Test only in **heating mode** to verify proper water flow.

Water or Glycol Filling (See page 28) A 10% minimum glycol mixture is suggested to protect the unit from freezing and provide corrosion inhibition. Refer to the chart on page 10.

1. With a hose and filling pump connected to the cx50 water system, and all air exhaust valves open in the water system, fill the water loop with water and glycol mixture. Keep the air exhaust valves open until there is a continuous flow of water and glycol mixture coming out of the air exhaust valve. Then close the air exhaust valves. See page 30 and 31 for more details.
2. Discharge the air from both domestic hot water system and air conditioning water system. CXI fan coils have a bleeder valve located near the inlet and outlet ports. The cx50 has a bleeder tube attached to the Brazed plate heat exchanger.

***To avoid freezing the heat pump when the air temperature drops below 32F in winter, you must use an appropriate glycol and water mixture just in case the electricity is cut off. We recommend biodegradable non-toxic HSE Corn Glycol, any Propylene Glycol (PG) can be used.***

Running a Test- Call tech support if this is your first time commissioning a cx50.

Apply power to the cx50 and select **heating mode** using the wired controller. If there is not enough flow in the system or air in the lines and you will get P5 and possibly P1 errors. Call tech support if any error codes are displayed on the wired controller.

**Chiltrix Tech Support hours of operation, M-F, 9 am-6 pm EST, 757-410-8640 x112**

### **MOST IMPORTANT!**

1. Always maintain an electrical connection with heat pump to enable the antifreeze function. 2. Initial test should be done in **heating mode**. Make sure it is not in cooling mode during first operation or running a test, until you make sure the circulation pump is working properly and water is flowing properly. Failure to do so will likely damage the heat exchanger and not be covered under warranty.



## Extending Wires

If you need to extend any of the sensor wires, control wires, MODBUS wires, please follow the instructions below as the wires are very sensitive to resistance and EMF.

Cut and strip the wire ends (1) that you wish to extend.

Twist the wires together (2) and then solder the wires (3) to create a good connection. Then cover the exposed solder and wire with heat shrink (4) and make sure you have a solid connection.

DO NOT use crimp style butt connectors, the small gauge wire tends to get cut when you crimp down on the connector.

**For extending Psychrologix cable, make sure to follow the twisted pair twist pattern.**

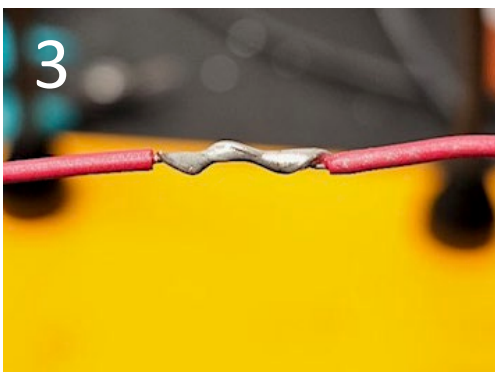
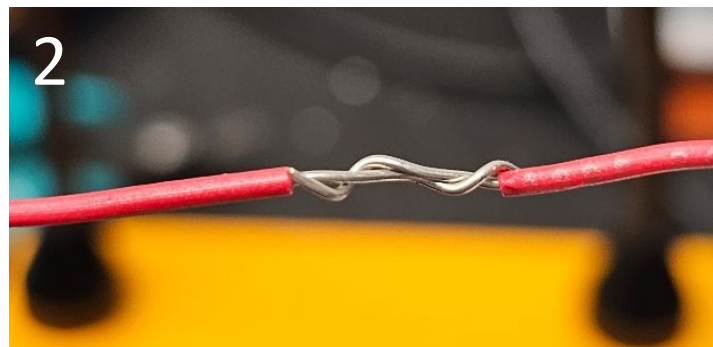
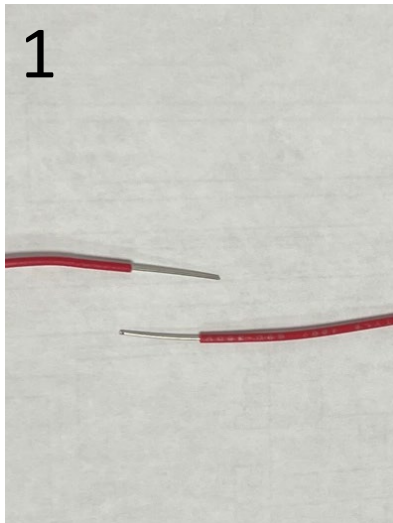

**DO NOT Run the modbus, temp sensor, dhw sensor, controller wires, or any logger wires in the same conduit as high voltage wires (120VAC or more). This will impede the accuracy and will cause communication problems. AVOID PASSING CONTROL WIRES NEAR ANY MOTORS OR INDUCTIVE LOADS OR DEVICES THAT EMIT EMF**